



FULL-SCALE SHELL IMPACT TEST OF A DOT-113 TANK CAR SURROGATE

SUMMARY

On June 11, 2020, the Federal Railroad Administration (FRA) conducted a full-scale shell impact test (Test 11) of a surrogate DOT-113 specification tank car at the Transportation Technology Center (TTC) in Pueblo, CO. This test was the second DOT-113 impact test in a planned series of four. A DOT-113 is a double-walled tank car (i.e., tank-within-a-tank) designed to transport authorized cryogenic liquids by rail. The test “surrogate” was purpose-built for this test with the essential features of a DOT-113 and an outer tank of a thicker, higher-grade steel than required by specification. The tested surrogate did not feature all the equipment required of a tank car (e.g., couplers and trucks). The shell of the outer tank was struck by a 297,000-pound ram car equipped with a 12-inch by 12-inch impactor at its mid-height and longitudinally offset 2 feet towards the A-end. This offset impact location was intended to be consistent with the impact location in the previous DOT-113 impact test in November 2019 (Test 10). [Figure 1](#) shows the tank car in its pre-test position against the impact wall at the TTC.



Figure 1. Pre-test Photo of DOT-113 Surrogate

The tank car was filled to 82.4 percent of its capacity with water. The car was sealed and pressurized with air to a targeted pressure of 50 psig. The target test speed of 17.2 ± 0.5 mph was intended to ensure an impact speed greater

than or equal to the measured impact speed of 16.7 mph from Test 10. The measured impact speed was 17.3 mph. This speed and ram mass corresponds to approximately 3 million foot-pounds of impact kinetic energy.

The tank car resisted the impact without tearing either the inner or the outer tank. After making contact, the impactor indented the DOT-113 surrogate to a maximum depth of ~61 inches before stopping and rebounding. The impact reached a maximum force of ~1.1 million pounds. [Figure 2](#) shows the tank car outer shell immediately following rebound of the ram car.



Figure 2. Post-test Photo of the Surrogate

BACKGROUND

FRA has established a program to evaluate the puncture resistance of various tank car designs. This program supports examining strategies to reduce the potential for release of hazardous materials from tank cars involved in derailments. FRA seeks to develop standardized test and simulation methodologies for quantifying the puncture resistance of tank car designs. This program has previously tested other specification tank cars (e.g., DOT-105, DOT-111, DOT-112, DOT-117, and DOT-113) under similar shell impact conditions. A companion finite element analysis (FEA) is performed prior to each test. The test results are used to both validate the pre-



test model and improve future finite element (FE) models. A well validated FE model can then be used to investigate other impact conditions.

In summary, Test 10, using a “legacy” DOT-113 tank car, resulted in puncture of both the inner and outer tanks [1]. Test 11, using a modified DOT-113 surrogate tank car did not puncture under similar test conditions.

OBJECTIVES

Test 11 planned to impact the DOT-113 surrogate under substantially-similar conditions to Test 10. The DOT-113 tank car in Test 10 test had an outer shell made from 7/16-inch American Society for Testing and Materials (ASTM) A516, Grade 70 carbon steel (A516) and perlite insulation. The DOT-113 surrogate used in Test 11 had an outer shell made from 9/16-inch Association of American Railroads’ (AAR) TC128 Grade B carbon steel (TC128) in the normalized condition and multi-layer insulation (MLI). The inner tank used in both tests was 1/4-inch ASTM A240 Type 304 (T304) stainless steel. Test 11’s objective was to examine the potential improvement in puncture behavior associated with this change in steel thickness and alloy. Future testing and modeling will evaluate how these results change when cryogenic conditions associated with use in service are considered.

METHODS

The outer tank of DOT-113 tank cars can be constructed of either A516 or TC128 steel of a minimum 7/16-inch thickness. As this test sought to examine the potential for improvement associated with a thicker outer tank of a different alloy than tested in Test 10, a purpose-built “surrogate” DOT-113 was used in this test. The DOT-113 tank car surrogate consisted of an outer carbon steel shell and an inner stainless-steel shell having approximately the same diameters as the DOT-113 in Test 10. The absence of ancillary components in the manufacture of the test surrogate, such as brake rigging, couplers, and other safety equipment was not expected to affect the test results. Key

parameters for Test 10 and Test 11 are summarized in [Table 1](#).

Table 1. Summary of Tank Car Parameters in Recent Tests

Parameter	Test 10	Test 11
Commodity in Tank	Water	Water
Tank Capacity (water, gallons)	32,900 (nominal)	19,300 (nominal)
Outage in Test	17.6%	17.6%
Outage Pressure (psig)	50	50
Outer Shell Thickness (inches)	7/16	9/16
Outer Shell Material (Carbon Steel)	A516	TC128 (normalized)
Inner Shell Thickness (inches)	1/4	1/4
Inner Shell Material (Stainless Steel)	T304	T304
Insulation Between Tanks	Evacuated Perlite	MLI (impact zone only)

Both the moving ram car and the stationary tank car were instrumented for this test. The acceleration, force, velocity, and displacement of the ram car were derived from accelerometers positioned on structural members of the ram car. Speed sensors on the ram car recorded its speed just prior to impact. Laser displacement transducers on the impact wall were positioned in-line with laser displacement transducers on the ram car to measure the external compression of the tank car at its vertical center. The tank car was instrumented internally with pressure transducers and string potentiometers. Externally, the tank car was instrumented with string potentiometers at the ends of the tank and at its support skids to measure the car’s overall motion. The test was recorded using conventional-speed and high-speed cameras on the ground and drone-mounted conventional-speed cameras in the air. The instrumentation is summarized in [Table 2](#).

Table 2. Summary of Instrumentation

Type of Instrumentation	Channel Count
Accelerometers	11
Speed Sensors	2
Pressure Transducers	13
String Potentiometers	10
Laser Disp. Transducers	15
Total Data Channels	51

The FEA was performed in conjunction with the test. A schematic of the FE model is shown in [Figure 3](#). This model featured simplified modeling of the water and the air within the tank.



The water was modeled using a hydraulic cavity approach, and the air was modeled as an ideal gas using a pneumatic cavity approach. The inner and outer tanks were modeled using shell elements, except in the impact zone, with elastic-plastic material properties. The impact zones of both the inner and outer tanks were modeled using solid elements, with elastic-plastic and ductile failure material properties defined. This combination of shell and solid element types allowed puncture of the tank car to be modeled while reducing the model's run-time.

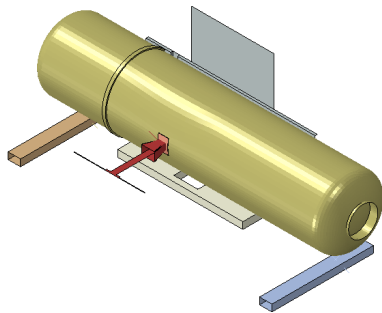

Figure 3. DOT-113 Surrogate FE Model

This test was the first test in this series to feature a purpose-built test article, rather than a tank car used in service. Thus, material coupons from the actual TC128 and T304 stainless steel were available for tensile testing prior to the test. The pre-test FE model used material models based on these tensile results. The pre-test models using these material behaviors predicted that the DOT-113 surrogate would not puncture either tank under the target test conditions.

RESULTS

The impact occurred at 17.3 mph and resulted in the ram car coming to a stop and rebounding without puncturing either tank. The force-displacement and energy-displacement results from the test are shown in [Figure 4](#). The force results are calculated by the average of the five longitudinal accelerometers on the ram car multiplied by the mass of the ram car. A CFC-60 filter has been used on these results in accordance with the Society of Automotive Engineers (SAE) J211-1.

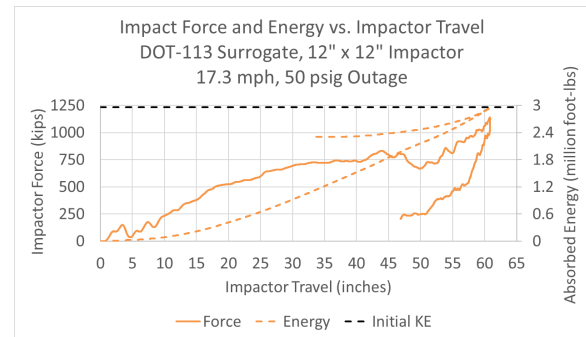

Figure 4. Test Force-displacement Results at 17.3 mph (CFC-60)

[Figure 5](#) shows a comparison between the force-displacement responses measured in Test 10 and Test 11. Both tests were performed using the same impactor, lading outage, and initial outage pressure. Test 10 had an impact speed of 16.7 mph and resulted in puncture of both the inner and outer tanks. Test 11 had an impact speed of 17.3 mph and did not result in puncture of either tank.

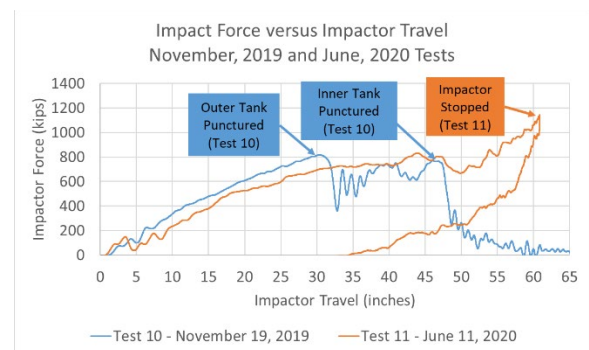

Figure 5. Force-displacement Results from Test 10 and Test 11 Tests (CFC-60)

[Figure 6](#) shows a comparison between the force-displacement response measured in the June 2020 test and the force-displacement results from the pre-test FE model updated with the measured impact speed of 17.3 mph. While the model included material behaviors that would allow both the inner and outer tank to puncture in the simulation, the model did not experience tearing in either tank under the simulated test conditions.

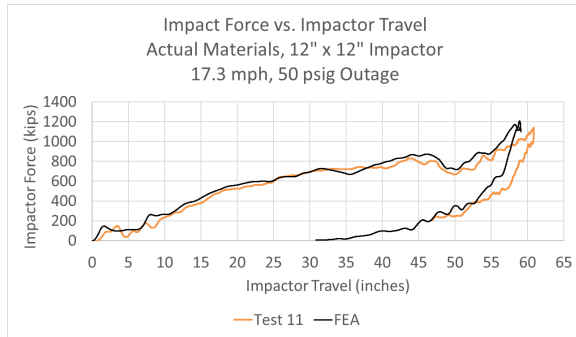

Figure 6. Test and FE Model Force-displacement Results at 17.4 mph (CFC-60)

CONCLUSIONS

A full-scale impact test of a surrogate DOT-113 test article occurred on June 11, 2020. The impact occurred at 17.3 mph with a 297,000-pound ram car equipped with a 12-inch by 12-inch impactor. This impactor speed and mass corresponded to an impact kinetic energy of approximately 3 million foot-pounds. The DOT-113 surrogate resisted the impact without puncture of either the inner or outer tank.

FUTURE ACTION

The test data, photos, and videos will be reviewed and compared with the behaviors from the FEA model for validation. If necessary, the pre-test FE model will be updated to reflect the actual impact conditions. The test and model results will also be compared with the corresponding measurements from Test 10. Additional post-test FEA is planned to investigate the impact response of the DOT-113 tank car when loaded under service conditions (e.g., cryogenic lading and temperature). Inner tank material properties (T304) will be investigated at the expected test cryogenic temperature and strain rate. Any improvements made in the DOT-113 surrogate post-test FE model will be incorporated into pre-test models of the planned

subsequent DOT-113 tests. Two additional shell impact tests of DOT-113 tank cars are planned under this program, as summarized in [Table 3](#).

Table 3. Planned DOT-113 Test Series

	Test Article	Lading
Nov. 2019: Test 10	Legacy DOT113	Water
June 2020: Test 11	Surrogate DOT-113	Water
TBD 2020: Test 12	Surrogate DOT-113	Liquid Nitrogen
TBD 2021: Test 13	New DOT-113	Liquid Nitrogen

REFERENCES

1. Federal Railroad Administration, "[Full-Scale Shell Impact Test of a DOT-113 Tank Car](#)," Research Results No. RR 20-03, February 2020.

ACKNOWLEDGEMENTS

FEA, test planning, and documentation were performed by the Volpe National Transportation Systems Center. Test planning, instrumentation, data collection, test conduct, and documentation were performed by Transportation Technology Center, Inc.

CONTACT

Francisco González, III
Hazardous Materials Program Manager
Federal Railroad Administration
Office of Research and Development
1200 New Jersey Avenue, SE
Washington, DC 20590
(202) 493-6076
francisco.gonzalez@dot.gov

KEYWORDS

DOT-113, tank cars, impact testing, puncture resistance, hazardous materials, hazmat, finite element analysis, model validation

CONTRACT NUMBER

DTFR53-11-D-00008, task 0008

Notice and Disclaimer: This document is disseminated under the sponsorship of the United States Department of Transportation in the interest of information exchange. Any opinions, findings and conclusions, or recommendations expressed in this material do not necessarily reflect the views or policies of the United States Government, nor does mention of trade names, commercial products, or organizations imply endorsement by the United States Government. The United States Government assumes no liability for the content or use of the material contained in this document.