

Report Nos.: DOT-TSC-OST-76-4/FRA-OR&D-76-142

## AN ASSESSMENT OF RAILROAD LOCOMOTIVE NOISE

Paul J. Remington  
Michael J. Rudd

Bolt Beranek and Newman Inc.  
50 Moulton Street  
Cambridge MA 02138

PROPERTY OF FRA  
RESEARCH & DEVELOPMENT  
LIBRARY



AUGUST 1976

FINAL REPORT

DOCUMENT IS AVAILABLE TO THE PUBLIC  
THROUGH THE NATIONAL TECHNICAL  
INFORMATION SERVICE, SPRINGFIELD,  
VIRGINIA 22161

Prepared for

**U.S. DEPARTMENT OF TRANSPORTATION**  
OFFICE OF THE SECRETARY  
Office of the Assistant Secretary for Systems  
Development and Technology  
Office of Noise Abatement  
and  
FEDERAL RAILROAD ADMINISTRATION  
Research and Development  
Washington DC 20590



**NOTICE**

This document is disseminated under the sponsorship of the Department of Transportation in the interest of information exchange. The United States Government assumes no liability for its contents or use thereof.

**NOTICE**

The United States Government does not endorse products or manufacturers. Trade or manufacturers' names appear herein solely because they are considered essential to the object of this report.

1. Report No. DOT-TSC-OST-76-4 FRA-OR&D-76-142		2. Government Accession No.		3. Recipient's Catalog No.	
4. Title and Subtitle  AN ASSESSMENT OF RAILROAD LOCOMOTIVE NOISE				5. Report Date August 1976	
7. Author(s) Paul J. Remington and Michael J. Rudd				6. Performing Organization Code DOT-TSC-OST-76-4 DOT-TSC-FRA-76-2	
9. Performing Organization Name and Address Bolt Beranek and Newman Inc.* 50 Moulton Street Cambridge MA 02138				8. Performing Organization Report No.	
12. Sponsoring Agency Name and Address U.S. Department of Transportation Office of the Secretary Office of the Asst. Sec. for Systems Development and Tech. Office of Noise Abatement Washington DC 20590				10. Work Unit No. OS607,RR616/R6513	
				11. Contract or Grant No. DOT-TSC-1016	
				13. Type of Report and Period Covered Final Report June-August 1975	
				14. Sponsoring Agency Code	
15. Supplementary Notes *Under contract to:		U.S. Department of Transportation Transportation Systems Center Kendall Square Cambridge MA 02142			
16. Abstract  Measurements of the noise generated by an SD40-2 diesel electric locomotive are described. The noise was measured in three types of moving tests: the first with the locomotive passing a 6-microphone array while under maximum power acceleration, the second with the locomotive simulating the pulling of a train, and the third with the locomotive coasting by unpowered. Stationary noise measurements were made at 16-microphone positions around the locomotive while it was attached to a load cell. The moving tests show that at the lower throttle settings, wheel/rail noise may be an important contributor to the overall locomotive noise signature even at modest speeds (20 mph and above at throttle 1 and 30 mph and above at throttle 4). At throttle 8, wheel/rail noise does not become a significant source until speeds in excess of 50 mph are reached. At throttle 8 and at speeds below 50 mph, noise spectra measured opposite the moving locomotive are comparable to noise spectra measured opposite the stationary locomotive. Diagnostic tests to determine how much the various sources contributed to the overall noise were performed at seven positions on one side of the locomotive. The engine exhaust and intake, the engine/generator, the radiator cooling fans, the dynamic brake fans, the traction motor blowers, the dust bin blower compressor, and structure-borne noise have all been identified. At high throttle settings the exhaust and radiator cooling fans dominate. At low throttle settings the engine/generator, the exhaust and the cooling fans all contribute to the overall noise.					
17. Key Words Noise, Railroad Noise, Locomotive Noise, Exhaust Noise, Fan Noise, In-Cab Noise, Wayside Noise, Ground Transportation Noise.			18. Distribution Statement  DOCUMENT IS AVAILABLE TO THE PUBLIC THROUGH THE NATIONAL TECHNICAL INFORMATION SERVICE, SPRINGFIELD, VIRGINIA 22161		
19. Security Classif. (of this report) UNCLASSIFIED		20. Security Classif. (of this page) UNCLASSIFIED		21. No. of Pages 168	22. Price



## PREFACE

This final report presents the results of a joint industry/government study of the generation of noise by a diesel electric locomotive. This report was prepared by Bolt Beranek and Newman Inc. under Contract No. DOT-TSC-1016 for the U.S. Department of Transportation. The SD40-2 locomotive and the personnel who operated it and otherwise supported the field tests were provided by Burlington Northern Railroad in cooperation with the Association of American Railroads. The exhaust system used during part of the field testing was provided on a rental basis by the Donaldson Company Inc.

This effort was technically coordinated at the Transportation Systems Center by Robert Mason. The help and cooperation of Harry Close of the Department of Transportation, James Coxey of the Association of American Railroads, Thomas G. Kotnour and Dale H. Propp both of Burlington Northern, and Rudy Pribramsky of the Electro-Motive Division of General Motors are gratefully acknowledged.

## METRIC CONVERSION FACTORS

### Approximate Conversions to Metric Measures

Symbol	When You Know	Multiply by	To Find	Symbol
<b>LENGTH</b>				
in	inches	2.5	centimeters	cm
ft	feet	30	centimeters	cm
yd	yards	0.9	meters	m
mi	miles	1.6	kilometers	km
<b>AREA</b>				
in <sup>2</sup>	square inches	6.5	sq. cm	cm <sup>2</sup>
ft <sup>2</sup>	square feet	0.09	sq. m	m <sup>2</sup>
yd <sup>2</sup>	square yards	0.8	sq. m	m <sup>2</sup>
mi <sup>2</sup>	square miles	2.6	sq. km	km <sup>2</sup>
	acres	0.4	hectares	ha
<b>MASS (weight)</b>				
oz	ounces	28	grams	g
lb	pounds	0.45	kilograms	kg
	short tons (2000 lb)	0.9	tonnes	t
<b>VOLUME</b>				
tsp	teaspoons	5	milliliters	ml
Tbsp	tablespoons	15	milliliters	ml
fl oz	fluid ounces	30	milliliters	ml
c	cups	0.24	liters	l
pt	pints	0.47	liters	l
qt	quarts	0.95	liters	l
gal	gallons	3.8	liters	l
ft <sup>3</sup>	cubic feet	0.03	cubic meters	m <sup>3</sup>
yd <sup>3</sup>	cubic yards	0.76	cubic meters	m <sup>3</sup>
<b>TEMPERATURE (exact)</b>				
°F	Fahrenheit temperature	5/9 (after subtracting 32)	Celsius temperature	°C

### Approximate Conversions from Metric Measures

Symbol	When You Know	Multiply by	To Find	Symbol
<b>LENGTH</b>				
mm	millimeters	0.04	inches	in
cm	centimeters	0.4	inches	in
m	meters	0.3	feet	ft
km	kilometers	0.6	miles	mi
<b>AREA</b>				
cm <sup>2</sup>	square centimeters	0.16	square inches	in <sup>2</sup>
m <sup>2</sup>	square meters	1.2	square yards	yd <sup>2</sup>
km <sup>2</sup>	square kilometers	0.4	square miles	mi <sup>2</sup>
ha	hectares (10,000 m <sup>2</sup> )	2.5	acres	
<b>MASS (weight)</b>				
g	grams	0.035	ounces	oz
kg	kilograms	2.2	pounds	lb
t	tonnes (1000 kg)	1.1	short tons	
<b>VOLUME</b>				
ml	milliliters	0.03	fluid ounces	fl oz
l	liters	2.1	pints	pt
l	liters	1.06	quarts	qt
l	liters	0.26	gallons	gal
m <sup>3</sup>	cubic meters	35	cubic feet	ft <sup>3</sup>
m <sup>3</sup>	cubic meters	1.3	cubic yards	yd <sup>3</sup>
<b>TEMPERATURE (exact)</b>				
°C	Celsius temperature	9/5 (then add 32)	Fahrenheit temperature	°F

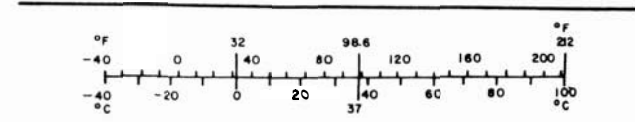

A.T.

## CONTENTS

Section		page
1.	INTRODUCTION .....	1
2.	TEST LOCOMOTIVE .....	3
	2.1 General Description .....	3
	2.2 Noise Sources .....	3
3.	TEST SITES AND INSTRUMENTATION .....	9
	3.1 Pass-by Tests .....	9
	3.2 Stationary Tests .....	12
	3.2.1 Baseline tests .....	14
	3.2.2 "Throttle wipe" tests .....	19
	3.2.3 Diagnostic tests .....	20
4.	TEST PROCEDURES AND RESULTS .....	22
	4.1 Pass-by Tests .....	22
	4.2 Stationary Tests .....	32
	4.2.1 Baseline tests .....	32
	4.2.2 "Throttle wipe" tests .....	40
	4.2.3 Diagnostic tests .....	49
	4.3 Comparison of Stationary and Pass-by Tests Results .....	62
5.	CONCLUSIONS AND RECOMMENDATIONS .....	68
	5.1 Test Results .....	68
	5.1.1 Pass-by tests .....	68
	5.1.2 "Throttle wipe" tests .....	68

**CONTENTS (Cont'd.)**

<b>Section</b>	<b>page</b>
5.1.3 Stationary baseline tests .....	68
5.1.4 Diagnostic tests .....	69
5.2 Noise Control .....	70
5.3 Future Work .....	73
APPENDIX A: BASELINE NOISE SPECTRA .....	77
APPENDIX B: DIAGNOSTIC MEASUREMENT SOURCE SPECTRA .....	107
APPENDIX C: AIRBORNE TRANSFER FUNCTIONS .....	130
APPENDIX D: STRUCTUREBORNE TRANSFER FUNCTIONS .....	137
APPENDIX E: LOAD CELL NOISE .....	147
APPENDIX F: REPORT OF INVENTIONS .....	153

## ILLUSTRATIONS

Figure		page
2.1	The Test Locomotive .....	3
2.2	Major Noise Source Locations in the SD40-2 Locomotive .....	4
2.3	Details of the Air Compartment .....	7
3.1	Microphone Locations for the Pass-by Test .....	11
3.2	Pass-by Test Instrumentation .....	12
3.3	Test Site for Stationary Noise Measurements .....	13
3.4	Baseline Microphone Locations .....	15
3.5	Load Cell Barrier .....	17
3.6	Typical Microphone Instrumentation Chain .....	18
3.7	Typical Accelerometer Instrumentation Chain .....	19
3.8	Diagnostic Test .....	21
4.1	Peak Coast-by Noise Levels .....	27
4.2	Locomotive Pass-by at 36 mph (Throttle 8) (West) ...	29
4.3	Locomotive Pass-by at 50 ft (West ) .....	30
4.4	Locomotive Pass-by at 50 ft (Throttle 8, West) .....	31
4.5	Coast-by Noise at 50 ft (38 mph) .....	32
4.6	Directivity of Locomotive Noise .....	34
4.7	Noise From Individual Throttle Settings, Location 4, Loaded .....	41
4.8	<b>Noise During "Throttle Wipe" Test. Location 4, Loaded</b>	<b>42</b>
4.9	Noise From Individual Throttle Setting, Location 4, Unloaded .....	43



ILLUSTRATIONS (Cont'd.)

Figure		page
4.10	Noise During "Throttle Wipe" Tests, Location 4, Unloaded .....	44
4.11	Noise From Individual Throttle Settings, Location 3, Loaded .....	45
4.12	Noise During "Throttle Wipe Tests, Location 3, Loaded .....	46
4.13	Noise From Individual Throttle Settings, Location 3, Unloaded .....	47
4.14	Noise During "Throttle Wipe" Tests, Location 3, Unloaded .....	48
4.15	Fully Quieted Locomotive, Looking East .....	52
4.16	Fully Quieted Locomotive, Looking Southwest .....	53
4.17	Locomotive Exhaust Stack to Muffler Transition Coupling .....	54
4.18	Comparison of Powered and Unpowered Pass-bys at 50 ft and Cooling Fan Operating .....	63
4.19	Comparison of Stationary and Pass-by Tests at Throttle 8, 25 ft, 36 mph .....	65
4.20	Comparison of Stationary and Pass-by Tests at Throttle 8, 50 ft, 36 mph .....	66
4.21	Comparison of Stationary and Pass-by Tests at Throttle 8, 100 ft, 36 mph .....	67
A. 1	Locomotive Baseline Noise, Idle, Microphone Location 1 .....	78
A. 2	Locomotive Baseline Noise, Throttle 4, Full Load, Microphone Location 1 .....	79
A. 3	Locomotive Baseline Noise, Throttle 8, Full Load, Microphone Location 1 .....	80

ILLUSTRATIONS (Cont'd.)

Figure		page
A.4	Locomotive Baseline Noise, Idle, Microphone Location 2 .....	81
A.5	Locomotive Baseline Noise, Throttle 4, Full Load, Microphone Location 2 .....	82
A.6	Locomotive Baseline Noise, Throttle 8, Full Load, Microphone Location 2 .....	83
A.7	Locomotive Baseline Noise, Idle, Microphone Location 3 .....	84
A.8	Locomotive Baseline Noise, Throttle 4, Microphone Location 3 .....	85
A.9	Locomotive Baseline Noise, Throttle 8, Full Load, Microphone Location 3 .....	86
A.10	Locomotive Baseline Noise, Idle, Microphone Location 4 .....	87
A.11	Locomotive Baseline Noise, Throttle 4, Full Load, Microphone Location 4 .....	88
A.12	Locomotive Baseline Noise, Throttle 8, Full Load, Microphone Location 4 .....	89
A.13	Locomotive Baseline Noise, Idle, Microphone Location 5 .....	90
A.14	Locomotive Baseline Noise, Throttle 4, Full Load, Microphone Location 5 .....	91
A.15	Locomotive Baseline Noise, Throttle 8, Full Load, Microphone Location 5 .....	92
A.16	Locomotive Baseline Noise, Idle, Microphone Location 6 .....	93
A.17	Locomotive Baseline Noise, Throttle 4, Full Load, Microphone Location 6 .....	94

ILLUSTRATIONS (Cont'd.)

Figure		page
A.18	Locomotive Baseline Noise, Throttle 8, Full Load, Microphone Location 6 .....	95
A.19	Locomotive Baseline Noise, Idle, Microphone Location 7 .....	96
A.20	Locomotive Baseline Noise, Throttle 4, Full Load, Microphone Location 7 .....	97
A.21	Locomotive Baseline Noise, Throttle 8, Full Load, Microphone Location 7 .....	98
A.22	Locomotive Baseline Noise, Idle, Microphone Location 8 .....	99
A.23	Locomotive Baseline Noise, Throttle 4, Full Load, Microphone Location 8 .....	100
A.24	Locomotive Baseline Noise, Throttle 8, Full Load, Microphone Location 8 .....	101
A.25	Locomotive Baseline Noise, Idle, Microphone Location 9 .....	102
A.26	Locomotive Baseline Noise, Throttle 4, Full Load, Microphone Location 9 .....	103
A.27	Locomotive Baseline Noise, Throttle 8, Full Load, Microphone Location 9 .....	104
A.28	The Range of Background Levels at Microphone Locations 3 and 6 .....	105
B.1	Source Spectra at Throttle 4, Full Load, Microphone Location 1 .....	108
B.2	Source Spectra at Throttle 8, Full Load, Microphone Location 1 .....	109
B.3	Source Spectra at Idle, Microphone Location 2 .....	110
B.4	Source Spectra at Throttle 4, Full Load, Microphone Location 2 .....	111

ILLUSTRATIONS (Cont'd.)

Figure		page
B.5	Source Spectra at Throttle 8. Full Load. Microphone Location 2 .....	112
B.6	Source Spectra at Idle. Microphone Location 3 .....	113
B.7	Source Spectra at Throttle 4, Full Load. Microphone Location 3 .....	114
B.8	Source Spectra at Throttle 8. Full Load. Microphone Location 3 .....	115
B.9	Source Spectra at Idle. Microphone Location 4 .....	116
B.10	Source Spectra at Throttle 4, Full Load. Microphone Location 4 .....	117
B.11	Source Spectra. Throttle 8. Full Load. Microphone Location 4 .....	118
B.12	Source Spectra. Idle. Microphone Location 5 .....	119
B.13	Source Spectra. Throttle 4, Full Load. Microphone Location 5 .....	120
B.14	Source Spectra. Throttle 8. Full Load. Microphone Location 5 .....	121
B.15	Source Spectra. Idle. Microphone Location 6 .....	122
B.16	Source Spectra. Throttle 4, Full Load. Microphone Location 6 .....	123
B.17	Source Spectra. Throttle 8. Full Load. Microphone Location 6 .....	124
B.18	Source Spectra. Idle. Microphone Location 7 .....	125
B.19	Source Spectra. Throttle 4, Full Load. Microphone Location 7 .....	126
B.20	Source Spectra. Throttle 8. Full Load. Microphone Location 7 .....	127

ILLUSTRATIONS (Cont'd.)

Figure	page
B.21 Fan Source Spectra. Throttle 4, Microphone Location 3 .....	128
B.22 Fan Source Spectra. Throttle 8. Microphone Location 3 .....	129
C.1 Air Compartment Airborne Path Transfer Function ....	131
C.2 Compressor Airborne Path Transfer Functions .....	133
C.3 Engine/Alternator Airborne Path Transfer Function ..	134
C.4 Dust Bin Blower Transfer Function .....	135
D.1 Structureborne Transfer Functions for Microphone Location 3 .....	139
D.2 Structureborne Transfer Functions for Location 7 ...	140
D.3 Structureborne Noise at Idle. Location 3 .....	141
D.4 Structureborne Noise at Throttle 4, Full Load. Location 3 .....	142
D.5 Structureborne Noise at Throttle 8. Full Load. Location 3 .....	143
D.6 Structureborne Noise at Idle. Location 7 .....	144
D.7 Structureborne Noise at Throttle 4. Full Load. Location 7 .....	145
D.8 Structureborne Noise at Throttle 8, Full Load. Location 7 .....	146
E.1 Load Cell Noise 6 ft from the Barrier .....	148
E.2 Load Cell Airborne Transfer Functions .....	149
E.3 Load Cell Noise at Throttle 4 .....	151
E.4 Load Cell Noise at Throttle 8 .....	152

## TABLES

Table		page
2.1	Engine Throttle Settings and Nominal Engine Rotation Rate .....	5
4.1	Test Schedule of Speed and Throttle Settings .....	22
4.2	In-Cab Noise Levels.....	24
4.3	Summary of Pass-by Noise Data .....	26
4.4	Overall Baseline Locomotive Noise Levels With 3 Cooling Fans Running .....	36
4.5	Summary of Diagnostic Tests .....	55
4.6	Fan Source Levels at Location 3 .....	57



## 1. INTRODUCTION

The objective of the program described in this report is the enhancement of the information and techniques that will be needed by DOT and the railroads in future locomotive noise measurements and noise control.

Noise measurements were performed on a diesel electric locomotive provided by Burlington Northern, in cooperation with the Association of American Railroads. They were made while the locomotive, an SD40-2 manufactured by the Electro-Motive Division of General Motors, was operated under simulated line-haul conditions, under maximum acceleration and, under coast-by conditions, and while it was stationary and connected to a load cell.

During moving operation, exterior noise from the locomotive was measured by a six-microphone array beside the track, and interior noise was measured by two microphones in the cab. During stationary operation, exterior noise was measured at up to 16 locations around the locomotive.

The tests had several goals. The purpose of the moving test was primarily to quantify, as well as possible, the in-service noise produced by the locomotive; of additional interest was the contribution of the wheel/rail noise to the overall noise signature. The stationary tests had two objectives. First, we wanted to determine how closely the noise produced in stationary tests simulates actual in-service noise. Therefore, the locomotive was tested (1) while operating steadily at a given throttle setting and (2) while rapid throttle changes were made. Second, various stationary tests were devised to determine the contribution of the various locomotive components to the overall noise signature.



Details of the locomotive noise sources are presented in Sec. 2, and the test sites are fully described in Sec. 3. The test procedure and results are presented in Sec. 4. Section 5 presents conclusions and noise control recommendations and suggestions for additional work.

## 2. TEST LOCOMOTIVE

### 2.1 General Description

The test locomotive was an SD40-2 diesel electric locomotive manufactured in February, 1972 by the Electro-Motive Division of General Motors. The locomotive, Serial No. 6332, was provided by the Burlington Northern Railroad directly out of line-haul service and represents a relatively new type of locomotive found typically in line-haul service in the United States (Fig. 2.1).

Twelve major noise sources that were investigated in the diagnostic phase of this program are shown in Fig. 2.2; in Sec. 2.2, we briefly describe each source and its operation.



### 2.2 Noise Sources

*The engine exhaust stack* on top of the locomotive hood allows the engine exhaust gases

to be vented to the atmosphere after passing through the turbo-charger. There is no muffler on the locomotive although the exhaust manifold and turbocharger provide some reduction in exhaust noise

*The engine*, a 3000-hp, 16-cylinder, 2-stroke-per-cycle, 45°V, turbocharged, diesel engine (EMD Model 645E3) is hard-mounted to the main frame rails of the locomotive. It can be operated at

FIG. 2.1. THE TEST LOCOMOTIVE.

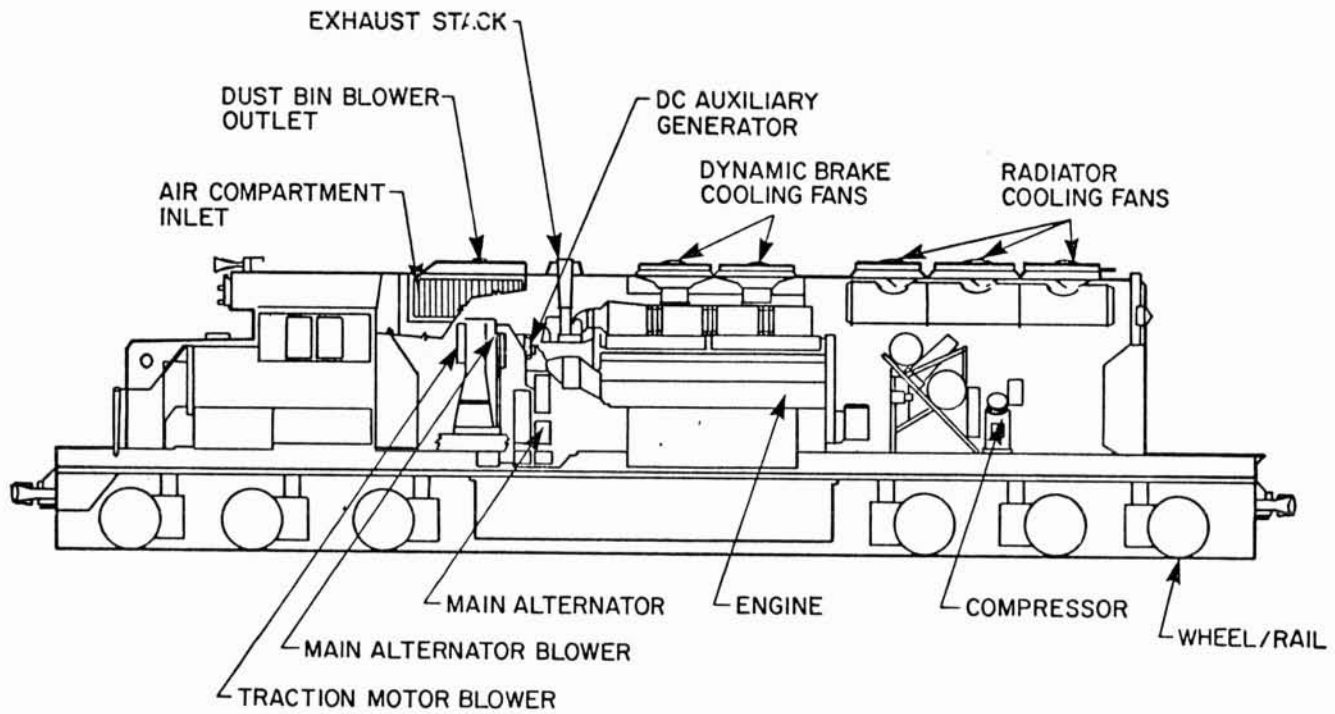

FIG. 2.2. MAJOR NOISE SOURCE LOCATIONS IN THE SD40-2 LOCOMOTIVE.

8 throttle settings and at idle. At each throttle setting, engine rpm is fixed, as is output power for most operating conditions. Throttle settings and corresponding nominal engine rotation rates are given in Table 2.1.\*

TABLE 2.1. ENGINE THROTTLE SETTINGS AND NOMINAL ENGINE ROTATION RATE.

Throttle Position	Engine rpm
idle	315
1	315
2	395
3	480
4	560
5	650
6	735
7	815
8	900

The *main alternator* (EMD Model AR10A7) driven by the engine is a three phase alternating current generator. Full wave rectified alternating current from the alternator powers the traction motors. Like the engine, the alternator is hard-mounted to the main frame rails of the locomotive. Physically attached to the main alternator but electrically independent is an auxiliary alternator (EMD Model D14) with a rating of 100 kVA that supplies power to the dust bin blower and to the radiator cooling fans. It also provides excitation for the main alternator.

\*Data provided by EMD.

The *air compressor*, located behind the engine, is hard-mounted to the floor of the engine compartment. It is a three-cylinder unit driven mechanically by the engine at the same speed as the engine. It supplies compressed air, on demand, primarily for the brake system.

Three 48-in.-diameter 8-bladed *radiator cooling fans* are mounted on top of the hood above the compressor. The fans are driven electrically at approximately twice engine speed by motors which are powered by the D-14 auxiliary alternator. One, two, or three fans may be running at any given time, depending on engine cooling requirements.

The *traction motor blower*, *main alternator blower*, and *dc auxiliary generator* are driven mechanically on a common shaft by the engine at three times the engine speed. The traction motor blower is a squirrel cage fan that absorbs about 122 hp at throttle 8 and supplies cooling air to all 6 traction motors while the main alternator blower that supplies cooling air to the main alternator absorbs only 20 hp. This cooling air is exhausted into the engine compartment where it creates a slight positive pressure that serves to prevent dirt from entering the compartment. The dc auxiliary generator supplies 10 kW of dc power for lighting, battery charging, control circuits, and excitation for the D-14 auxiliary alternator.

The *air compartment intake* provides an opening for exterior air to enter the air compartment (a small room between the cab and the engine compartment, where the intakes for the engine, tractor motor, and main alternator are located). Figure 2.3 shows details of the equipment in the air compartment.

The *dust bin blower* is a small (approximately 10 hp) blower that exhausts from the top of the locomotive hood. It provides

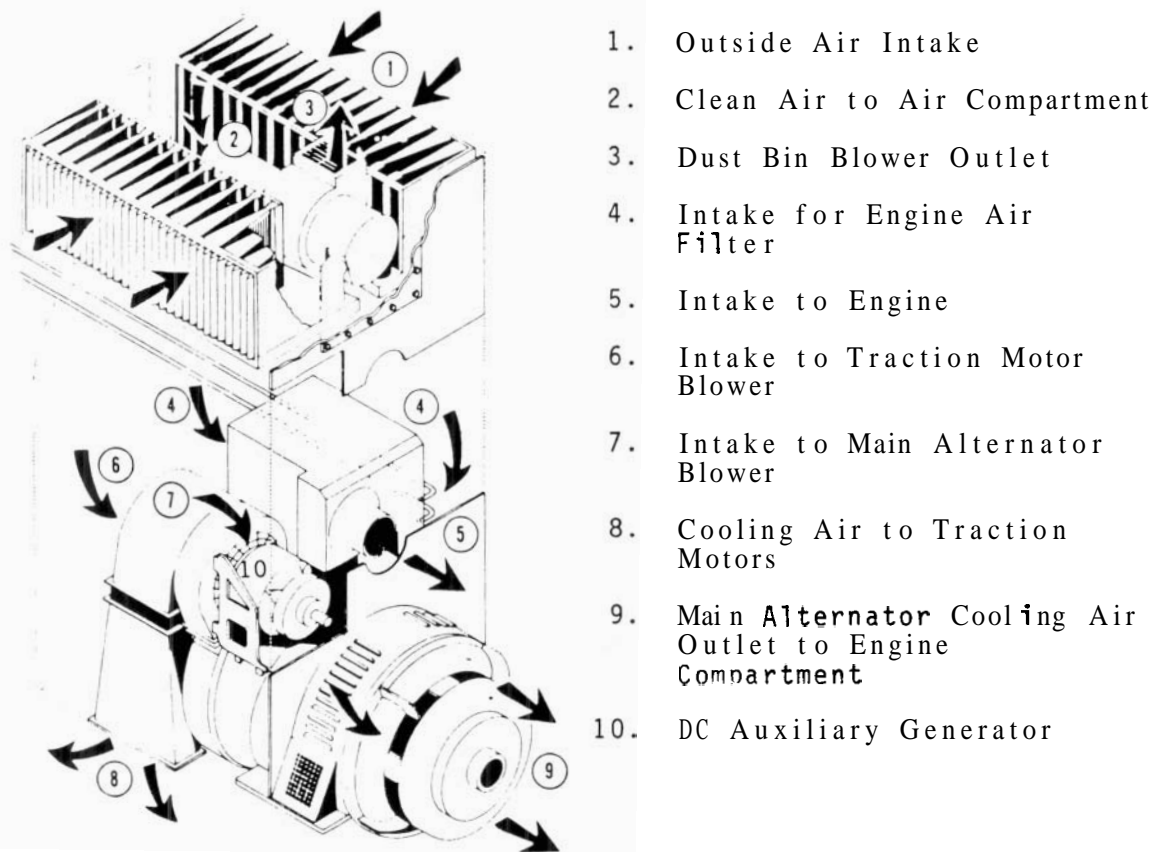

1. Outside Air Intake
2. Clean Air to Air Compartment
3. Dust Bin Blower Outlet
4. Intake for Engine Air Filter
5. Intake to Engine
6. Intake to Traction Motor Blower
7. Intake to Main Alternator Blower
8. Cooling Air to Traction Motors
9. Main Alternator Cooling Air Outlet to Engine Compartment
10. DC Auxiliary Generator

FIG. 2.3. DETAILS OF THE AIR COMPARTMENT.

inertial separation of dirt particles from the air entering the air compartment.

Two *dynamic brake fans* are located on top of the hood above the engine. These fans are 48 in. in diameter and each has 10 equally spaced blades. They provide cooling air for the dynamic brake resistor grids. The fans are connected in series with the grids and, hence, their rotation rate depends on the load applied to the grids during braking or self-load.

*Wheel/rail* noise is that noise associated with the interaction between the wheels and the rails as the locomotive rolls along the track.

### 3. TEST SITES AND INSTRUMENTATION

#### 3.1 Pass-by Tests

##### *Test Site*

The pass-by tests were conducted on a section of main line passenger track owned by Burlington Northern near the Old Great Northern Q-Yard within the city limits of St. Paul, Minnesota. The track ran approximately west to east and had a speed limit of 55 mph. The track was jointed with 120 lb/yd 34-ft rails, mounted on clean ballast, and was in good repair. Regular daily traffic on the track consisted of two scheduled passenger (AMTRAK) trains and one or two unit coal trains. The track was clear of junctions and obstructions for about 3 miles on either side of the test section, easily enabling top speed to be reached. The track through the test section itself was straight, although there was a slight curve, of radius greater than 2000 ft, beyond one end of the test section.

There were four parallel pairs of tracks at the test site; we used the second one from the southwest (a westbound passenger track). Southwest of the test track, the grade dropped about 8 ft from the embankment of the track to a wide, graveled area. Beyond this area (approximately 200 ft) were more trucks on which grain cars were parked at times. To the north, the grade dropped only about 4 ft to an unused part of the yard, covered with sparse vegetation, approximately 2 ft high.

Advantages of the test site were:

- a. It was in a good state of repair.
- b. A high top speed could be attained.
- c. No sharp curves were near the test section.



- d. There were no adjacent large reflecting surfaces or trees.
- e. Ambient noise was moderately low.

Disadvantages were:

1. The test track was elevated 4 to 8 ft above the surrounding grade.
2. On one side, the test area was covered with vegetation of unknown characteristics.
3. Grain cars parked 250 ft away and an embankment 300 ft away caused reflections.
4. A highway 1200 ft away contributed to the ambient noise.
5. A switching yard nearby also raised the ambient noise intermittently.

By and large however, the St. Anthony Tower test site was considered good for acoustic measurements of the SD40-2 locomotive.

During pass-by tests, locomotive noise was measured by six microphones set out in a line perpendicular to the track, as shown in Fig. 3.1. Pairs of microphones were set at 25, 50, and 100 ft on each side of the track centerline. Because the grade generally dropped below the track, the microphones were mounted on tall wooden stakes for a uniform height of 5 ft above the rail running surface.

#### *Instrumentation*

The instrumentation chain is shown in Fig. 3.2. Cables were run from each of the six microphones to a 6-channel amplifier and then into a 7-channel tape recorder. The levels of the signals being tape-recorded were monitored by meters on each of the

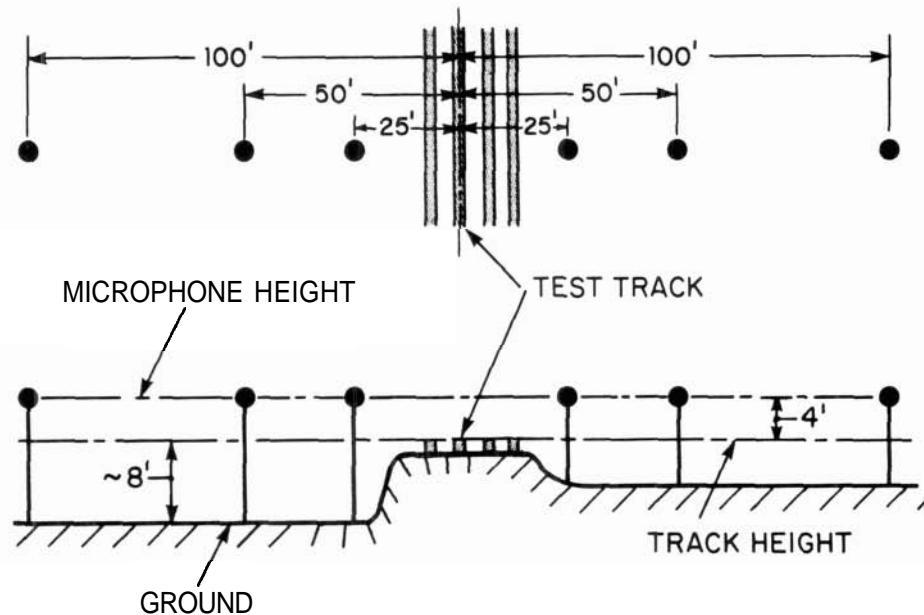

FIG. 3.1. MICROPHONE LOCATIONS FOR THE PASS-BY TEST.

amplifiers. The seventh channel of the tape recorder was used to record the outputs from the locomotive position sensors, a series of six photocells mounted at 20-ft intervals beside the track. A headlamp from the locomotive was mounted on the front steps of the locomotive and was used to trigger the photocells. The pulses from the six photocells were recorded on one channel of the tape recorder and used in the analysis to synchronize the data from all the microphones.

In addition to external noise, measurements were made inside the locomotive cab at locations corresponding to 6 in. from the operator's and brakeman's ears, with windows open and closed. These locations corresponded to approximately 4 ft above the floor. Overall measurements were made with a 1/2-in. microphone and B&K No. 2203 sound level meter during the pass-by tests.

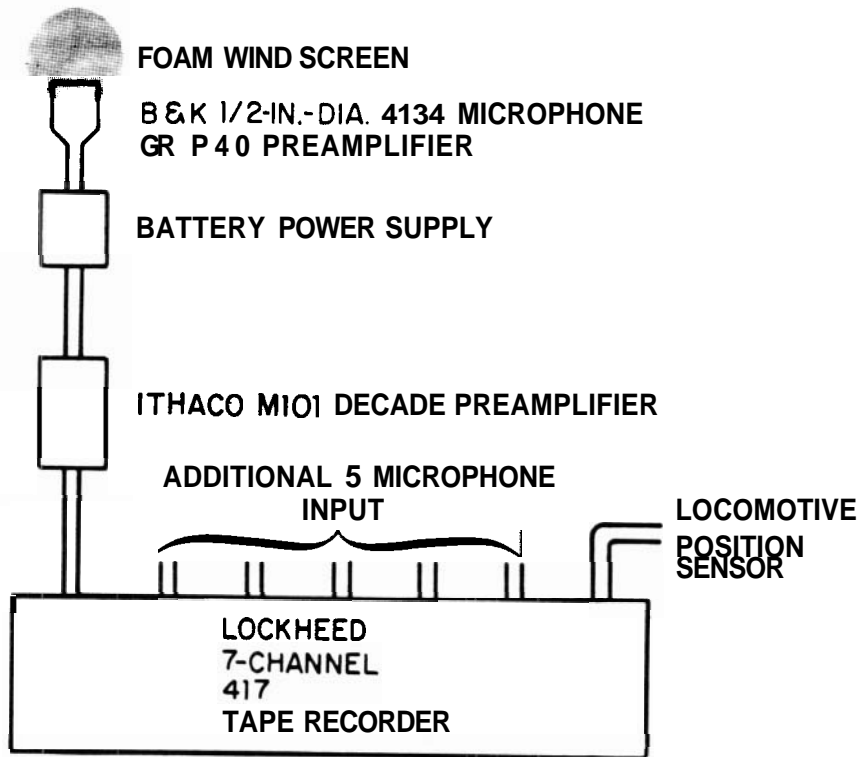

FIG. 3.2. PASS-BY TEST INSTRUMENTATION.

### 3.2 Stationary Tests

The site for the stationary noise testing of the locomotive was selected by the authors with the help of Burlington Northern personnel. We sought a geographically flat site with low background noise and no significant reflecting objects within 200 ft of the locomotive. The site we finally chose was near the pass-by test site at the old Great Northern Q-Yard, a presently unused freight yard within the city limits of St. Paul near the Minneapolis-St. Paul boundary. Figure 3.3 shows three views of the test site with the locomotive and load cell located for testing. In terms of flatness and lack of reflecting objects, the site was



a. View Looking West.

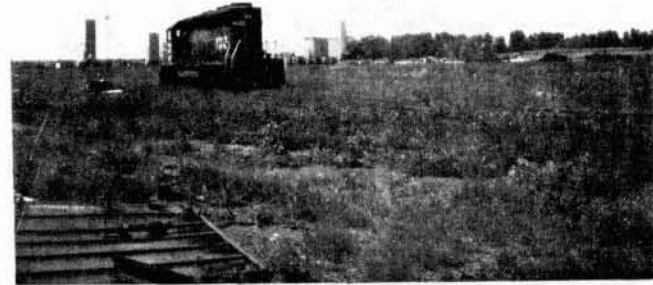

b. View Looking Northwest.



c. View Looking East.

FIG. 3.3. TEST SITE FOR STATIONARY NOISE MEASUREMENTS.

excellent. It did have two disadvantages: The field was overgrown with weeds approximately 2 ft high and the background noise caused some problems. The most serious background noise sources were an expressway a quarter-mile east of the site, an active Chicago Northwestern freight yard north and west of the site, occasional jet aircraft flyovers, and occasional line-haul freight and passenger trains on the active tracks surrounding the yard. All noise sources but the highway were eliminated by choosing measurement periods when these sources were not operating.

Three stationary noise tests were performed at this site. They were:

- a. Baseline tests of the noise generated by the locomotive in steady operation at a given throttle setting loaded by a resistor bank load cell.
- b. "Throttle wipes", i.e., baseline tests of the noise generated during rapid throttle changes.
- c. Diagnostic tests to determine the noise generated by the various noise sources in the locomotive.

The site configuration and the instrumentation for each of these tests are described in the following sections.

### 3.2.1 Baseline tests

#### *Test Configuration*

For the measurements of the noise generated by the locomotive while stationary and loaded by the resistor bank load cell, we initially considered a 10 microphone array surrounding the locomotive at a radial distance of 100 ft from the geometric center and 6 additional microphones on a perpendicular to the locomotive axis at 25 and 50 ft.

In practice, it was not possible to move the load cell sufficiently far away so that it would not interfere with the surrounding array of microphones both as a reflecting object and as an extraneous noise source. This was due primarily to the high cost of long lengths of copper cable heavy enough to carry the current load from the locomotive to the load cell. Consequently, we decided to use the microphone array and locomotive load cell configuration shown in Fig. 3.4. This configuration provided

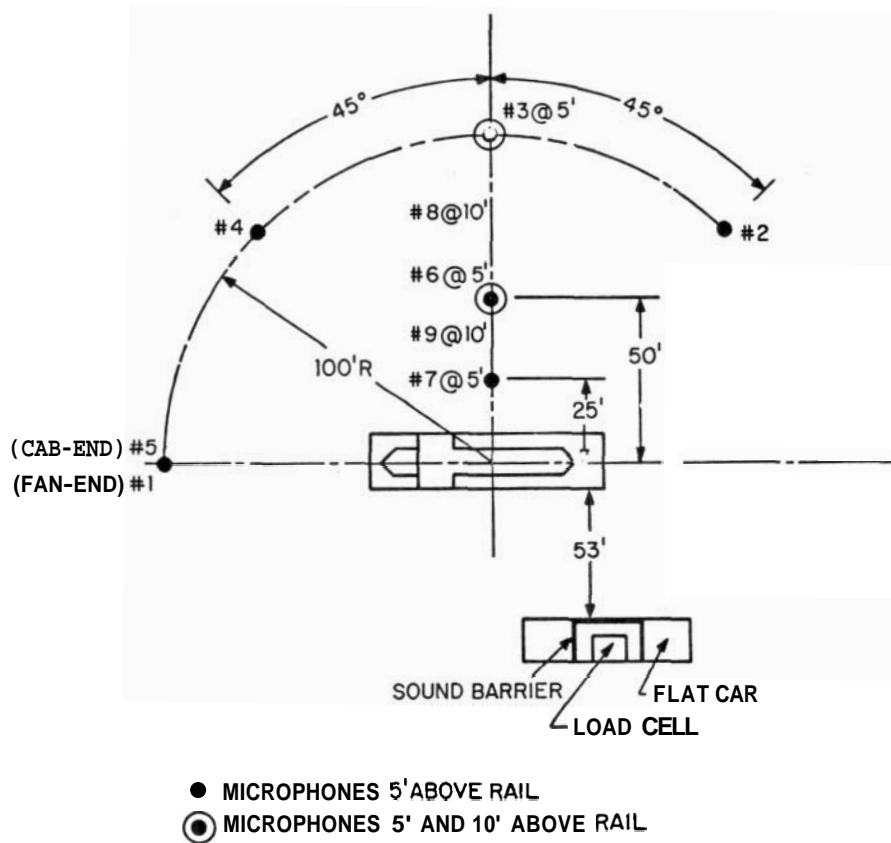

FIG. 3.4. BASELINE MICROPHONE LOCATIONS.

half the microphone locations planned for in the original array. Data at the remaining locations were obtained by turning the locomotive around. The microphone locations are each numbered in Fig. 3.4 for easy reference. Note that two numbers are used to designate the microphone on the locomotive axis. When the front or cab end of the locomotive faces this microphone it is referred to as No. 5. When the aft or cooling fan end faces this microphone it is referred to as No. 1. This numbering scheme was used primarily to be consistent with the scheme used for the microphone array in the diagnostic tests described in Sec. 3.2.3.

A General Electric air-cooled resistor bank load cell was mounted on a flat car and located such that the locomotive acted as a barrier between the load cell and most of the microphone positions, thereby reducing the contamination of the locomotive noise by the noise from the load cell blower. To reduce load cell noise even more, a 3/4-in.-thick plywood barrier approximately 8 ft high was constructed around three sides of the load cell (Fig. 3.5). Appendix C describes a number of measurements performed to determine the noise level generated by the load cell at the microphone locations of Fig. 3.4. The front surface of the load cell barrier was tilted back at an angle (approximately 15°) and all three exterior surfaces were covered with 3 in. of fiberglass to reduce reflections that might contaminate the measurements. Six 100-ft-long cables were used to connect the locomotive to the load cell. However, because of restrictions on location and because a considerable length of cable was required to link the load cell and the output busses of the main alternator inside the locomotive, the load cell could be placed only 53 ft from the locomotive (Fig. 3.4).

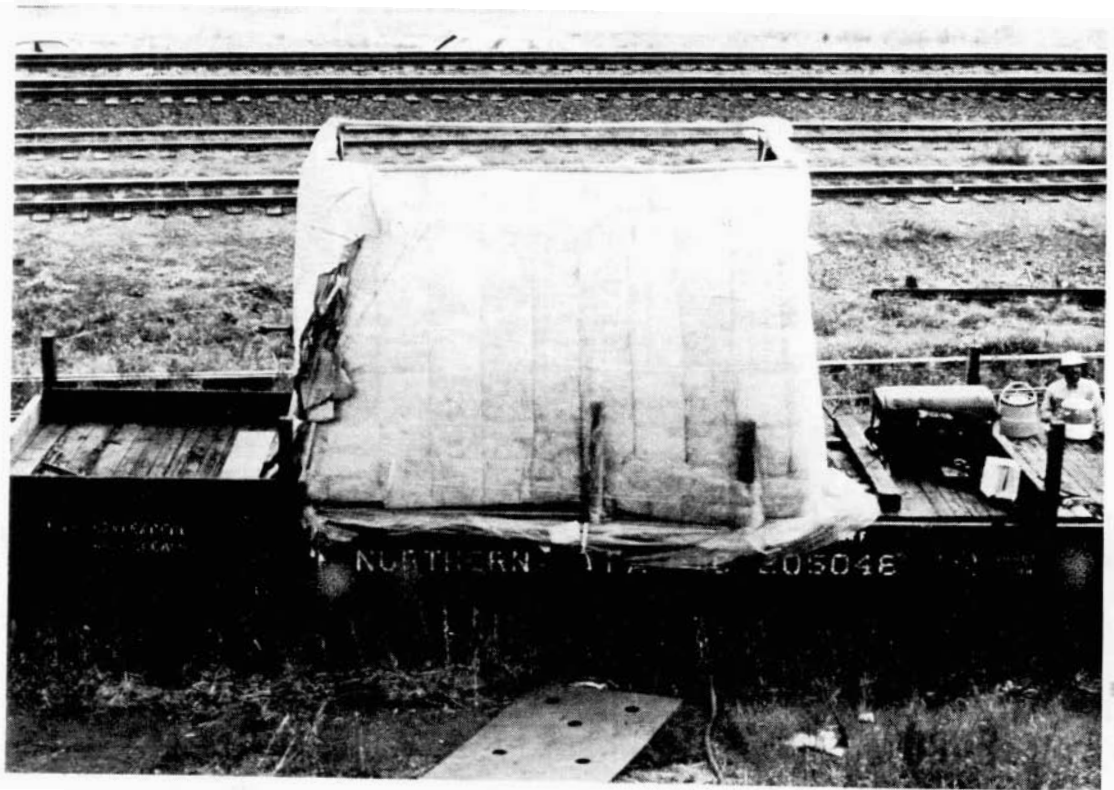

FIG. 3.5. LOAD CELL BARRIER.

#### *Instrumentation*

Both noise and vibration were measured during the baseline test sequence. The noise was measured at the 8 microphone locations in Fig. 3.4, and the vibration was measured at the main alternator, engine, compressor, radiator cooling fan, and dynamic brake cooling fan mounting points.

A typical microphone instrumentation chain is shown in Fig. 3.6. Up to seven microphones were running at any given time, not always with the same equipment. Occasionally, a B&K No. 2209 microphone power supply was substituted for the GR P40. In



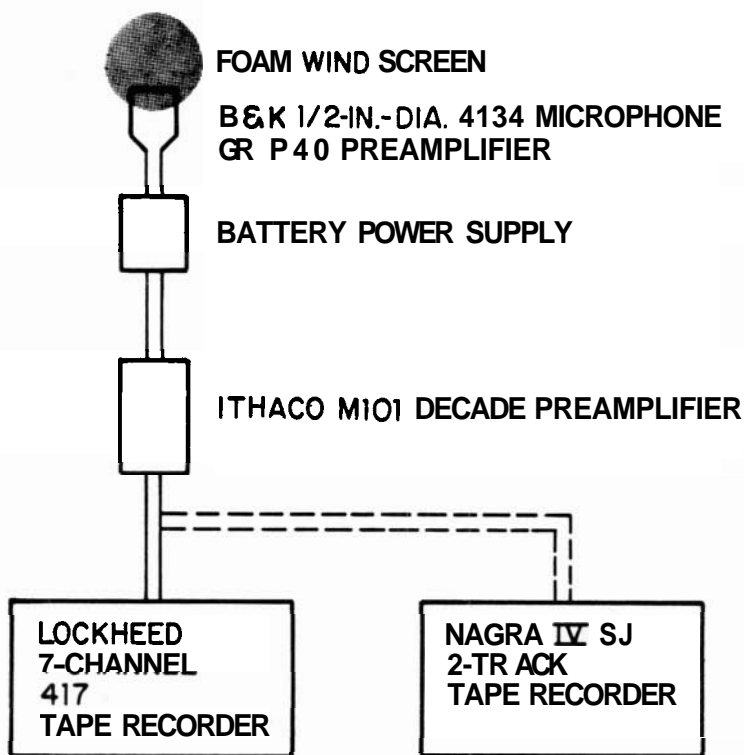

FIG. 3.6. TYPICAL MICROPHONE INSTRUMENTATION CHAIN.

addition, a General Radio 1-in. crystal microphone and P42 pre-amplifier were substituted for the B&K microphone and GR P40 pre-amplifier at a given location when the latter failed. Though the Lockheed tape recorder was used at 3-3/4 ips for most multichannel recordings, failure of the drive system on that instrument later in the program required all subsequent recordings to be made using the Nagra recorder at 7.5 ips, two channels at a time. For all cases in which only two channels were required, the Nagra machine was used in place of the Lockheed. Acceleration records were similarly obtained. A typical accelerometer instrumentation chain is shown in Fig. 3.7.

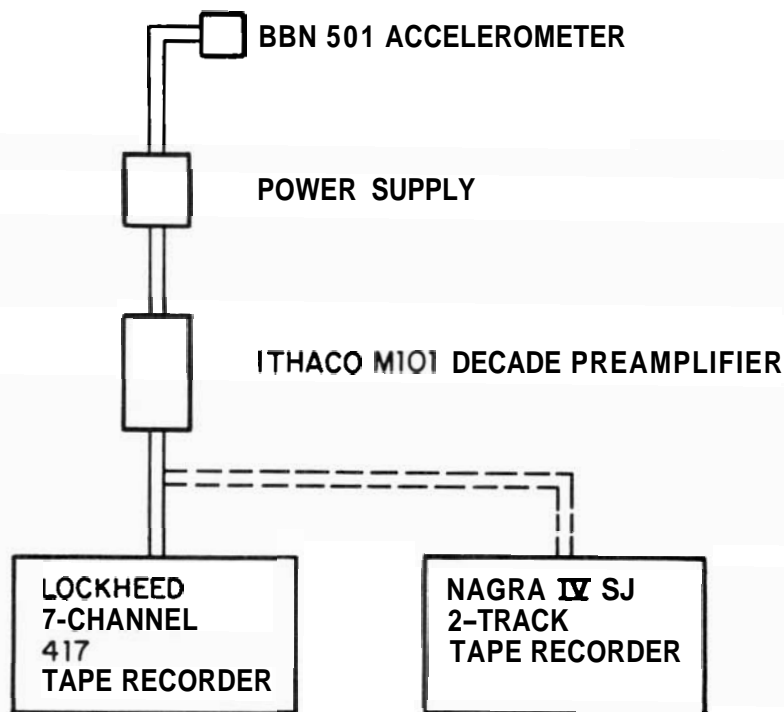

FIG. 3.7. TYPICAL ACCELEROMETER INSTRUMENTATION CHAIN.

The major differences between the performance of the two tape recorders of interest for this program are the frequency response below 100 Hz and the dynamic range. The Lockheed required +16-dB compensation in the 63-Hz 1/3-octave band and +6-dB compensation in the 80-Hz 1/3-octave band. The Nagra required no compensation. The Lockheed on direct record has a dynamic range of approximately 42 dB and the Nagra approximately 65 dB.

### 3.2.2 "Throttle wipe" tests

#### *Test Configuration*

The locomotive was set up as in the baseline tests, and two microphones were employed at positions 3 and 4, 100 ft from the

geometric center of the locomotive. Measurements were performed only on the right side of the locomotive.

#### *Instrumentation*

The outputs from the two microphones were recorded on a Nagra stereo SJ-IV tape recorder (see Fig. 3.6) and later played back, through an A-weighting filter, into a graphic level recorder.

### 3.2.3 Diagnostic tests

#### *Test Configuration*

For the diagnostic tests the locomotive and load cell were set up as for the baseline tests described in Sec. 3.2.1. Seven microphones mounted 5 ft above the rail and located as shown in Fig. 3.8 were used. The microphone locations are numbered in a manner consistent with the numbering scheme in Fig. 3.4 for the baseline tests. Note again that microphone No. 5 is in front of the locomotive and No. 1 is at the rear of the locomotive.

#### *Instrumentation*

The instrumentation for the diagnostic tests is the same as that described in Sec. 3.2.1 for the baseline tests. The diagnostic tests, however, were done late in the measurement program after failure of the Lockheed tape recorder. As a result, all recording was made on the Nagra tape recorder either one or two channels at a time through a switch box.

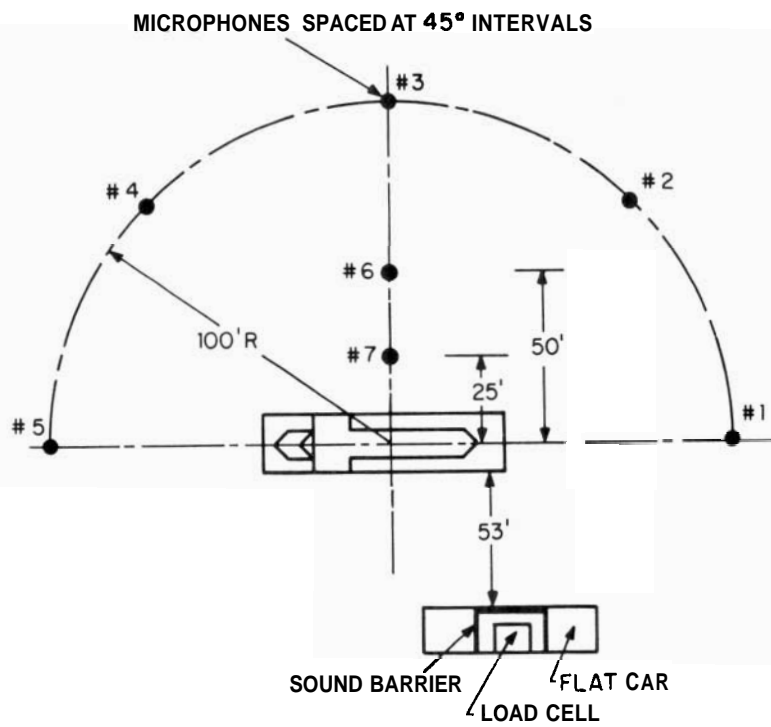

FIG. 3.8. DIAGNOSTIC TEST.

#### 4. TEST PROCEDURES AND RESULTS

##### 4.1 Pass-by Tests

###### *Test Procedure*

The locomotive, operated by a crew of two, was switched on to the main westbound passenger line. A two-way walkie-talkie radio was used to maintain contact with the locomotive crew. The locomotive was run through the test section at the 11 combinations of speed and throttle settings listed in Table 4.1. Note that tests 4 and 7 are nominally the same. Test 4 was supposed to be at steady speed and test 7 at maximum acceleration, but in practice there was virtually no difference between the two cases.

TABLE 4.1. TEST SCHEDULE OF SPEED AND THROTTLE SETTINGS.

Test No.	Throttle Setting	Nominal Speed mph	Actual Speed mph	Description
1	1	10	7-12	Simulated line haul condition
2	1	20	18-20	Simulated line haul condition
3	4	40	32-39	Simulated line haul condition
4	8	55	57-61	Simulated line haul condition
5	8	20	29-36	Full acceleration condition
6	8	40	50-55	Full acceleration condition
7	8	55	57-61	Full acceleration condition
8	Shut down	10	8-12	Wheel/rail noise tests
9	Shut down	20	15-20	Wheel/rail noise tests
10	Idle	40	38-41	Wheel/rail noise tests
11	Idle	55	52-55	Wheel/rail noise tests

During most of the tests, the locomotive, accelerated to the required speed and passed through the test section at the required throttle setting. In practice, obtaining the required speed in the test section was difficult as is readily apparent from a comparison of nominal and actual (photocell determined) speeds in Table 4.1. The locomotive was then stopped using both dynamic brakes (except when the engine was shut down) and air brakes, reversed, and run through the test section in the opposite direction. For tests 8 and 9, the engine was shut down just before entering the test section. In tests 10 and 11, it was switched to idle, so that dynamic braking was retained to stop the locomotive. This was required so that main generator current was available to excite the traction motor field. The motors then became generators and their power was dissipated in the dynamic brake resistor grids. At high speeds use of the dynamic brakes reduces considerably the wear on the air brake system. When all the tests had been conducted with the locomotive traveling forward and in reverse, the locomotive was turned around and the runs repeated. This procedure gave a total of 44 runs to be analyzed.

#### *In-Cab Test Results*

Table 4.2 gives the results of the in-cab noise measurements. Speeds were determined using only the in-cab speedometer. As expected, there is little difference between the measurements at the operator and brakeman positions.

At low throttle settings, there is practically no change in the noise with the cab windows open or closed. At throttle 8, opening the window increases noise by 2.5 to 4 dBA.

TABLE 4.2. IN-CAB NOISE LEVELS.

Speed m/h	Throttle	Window	Forward (dBA)		Backward (dBA)	
			Operator	Brakeman	Operator	Brakeman
10	Idle	Closed	68	68	--	--
10	1	Closed	69.5	69.5	69	69
10	1	Open	71	71.5	69.5	70
20	Idle	Closed	68.5	69	--	--
20	1	Open	69.5	70.5	69.5	69.5
20	1	Closed	70.5	71	70.5	70.5
20	8	Closed	82.5	81.5	84	83.5
40	Idle	Closed	71	71	71	71.5
40	4	Closed	76	75.5	76.5	76.5
40	8	Closed	--	--	83	83
55	Idle	Closed	73.5	74	74	74
55	8	Closed	84	83.5	82	81.5
55	8	Open	--	--	84.5	85.5

### *Wayside Test Results*

Wayside measurements are tabulated in Table 4.3. Both powered pass-by and unpowered coast-bys were measured. Peak coast-by noise levels are plotted as a function of true locomotive velocity in Fig. 4.1. Straight lines have been fitted to the data points in Fig. 4.1 using the method of least squares. The resulting equations are

$$L_a = 28 \log V + 45.8 @ 25 \text{ ft}$$

$$L_a = 23.3 \log V + 43.7 @ 50 \text{ ft}$$

$$L_a = 23.5 \log V + 37.4 @ 100 \text{ ft}$$

where  $L_a$  is the peak A-weighted sound pressure level at the given distance from the track centerline and  $V$  is the speed in miles per hour. The sound level can be seen to increase like  $V^2$  or  $V^3$  which is the range of velocity dependence commonly found for wheel/rail noise. Note that at 100 ft the measured levels had to be corrected downward 1 to 2 dBA at low speeds because of the relatively high background. When the wheel/rail noise of Fig. 4.1 is compared with the powered drive-by data in Table 4.3, It is apparent that wheel/rail noise can be a significant contributor to locomotive noise at low throttle settings. At throttle 1, wheel/rail noise is comparable to powered pass-by noise at speeds in excess of 20 mph. At throttle 4, wheel/rail noise and powered drive-by levels become comparable at speeds between 30 and 40 mph. At throttle 8, however, wheel/rail noise is 3 to 6 dBA below the overall locomotive drive-by levels at speeds as high as 61 mph.



TABLE 4.3. SUMMARY OF PASS-BY NOISE DATA.

Event No.	Speed (mp)	Distance (ft)	Direction (E or W)	25 E North		E South		E North		50 E South		100 E South	
				Peak Level (dB)	Time*	Peak Level (dBA)	Time*	Peak Level (dBA)	Time*	Peak Level (dBA)	Time*	Peak Level (dBA)	Time*
8	28	00	W	74	46	74	5.0	67	50	69	5.0	62†	-
			E	71	56	73	6.0	67.5	70	65	8.0	60†	-
1	127	11	W	77	37.5	79	0.2	72	50	72	6.5	67	-
			E	75.5	80	75	3.0	71	120	70	4.0	68	-
3	2015	00	W	81	25	85	2.1	73	30	74	3.0	69	8.0
			E	78	40	81	3.2	70	45	71	4.0	65†	-
2	2018	11	W	80	25	87	3.0	76	01	75	3.2	69.5	6.0
			E	80	35	88	1.2	74	74	75	3.2	70	7.0
10	4138	00	W	88	15	90	1.2	82	16	80	1.3	76	2.5
			E	89	14	91	1.3	80	22	78	1.6	75	2.3
3	3932	44	W	89	12.5	92.5	1.2	85	1.5	83	1.4	78	3.2
			E	89	16	92.5	1.6	84.5	1.9	82	2.4	79	4.0
5	3629	88	W	94	16	96	0.9	90	2.2	88.5	2.0	85	6.0
			E	94	25	94	0.9	90	2.2	88	2.2	84	9.0
11	5552	00	W	95	10	96	0.9	86	1.6	84	1.3	76	2.2
			E	93	11	96	1.1	86	1.5	84	1.3	79	2.5
6	5550	33	W	94.5	12	97	0.9	88	1.5	88	1.2	81	4.0
			E	97	16	98	0.1	90.5	1.9	88.5	1.9	87	3.2
4	6158	88	W	99	08	103	0.75	93	1.1	92	1.1	86	2.2
			E	98	09.5	101	0.75	92	1.3	92	1.4	86	3.0
4	6157	33	W	97	09	101	0.9	92.5	1.5	91	1.1	87	2.4
			E	99	09	99	0.9	91.5	1.2	88.5	1.1	87	2.6
7	6161	88	W	99	09	100	0.9	92	1.2	91.5	1.2	86.5	3.2
			E	100	08	99	1.0	92	1.2	91.5	1.2	87.5	2.5
7	0781	88	W	97	10	99	0.8	90	1.6	90.5	1.1	88	3.2
			E	99	09.5	100	0.9	91	1.2	91	1.1	87.5	3.0

\*The time period during which the noise was within 3 dBA of the peak.  
 †Corrected for background 58-60 dBA.

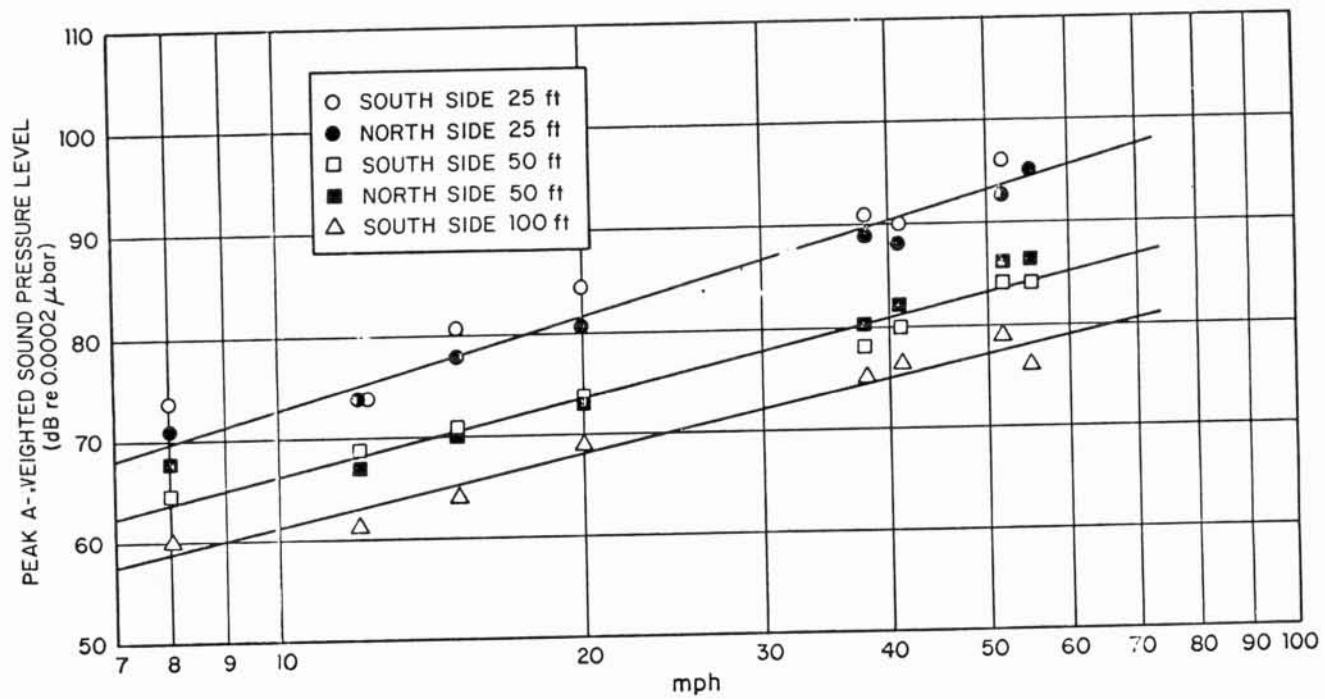

FIG. 4.1. PEAK COAST-BY NOISE LEVELS.

The throttle setting of the SD40-2 locomotive determines engine speed and power output. Therefore, for those speeds at which wheel/rail noise is not a significant source, locomotive noise should be independent of speed. In general, a slight increase in wayside noise level with speed is noticeable for all throttle settings. This result is consistent with the previous statement - that wheel/rail noise is becoming a significant noise source at the highest speeds examined for each throttle setting.

A few examples of the A-weighted sound pressure level as a function of time are given in Figs. 4.2 through 4.5. The "tick" marks above each time trace indicate the locomotive headlight passing over a photocell at track side. These marks provide both position and speed information on the locomotive. Figure 4.2 shows the change in the trace for the three distances from the locomotive. The farther away the observation point, the lower the level but the longer the noise persists. There is also a strong asymmetry in the traces, i.e., they are not symmetric about the time that the locomotive centerline passes the line of microphones. In fact, when we listened to the tapes, we heard a strong "hissing" sound **after** the locomotive leaves the test zone. Evidence of this can be seen in Fig. 4.2 in the second peak in the noise at 25 ft (and to a lesser extent at 50 ft) approximately 3.25 sec after the centerline of the locomotive passes the microphone. At 100 ft, there is no peak but the noise level remains high long after the locomotive centerline passes the microphones. The source of the "hissing" sound is presently unexplained.

Figure 4.3 shows the noise produced at 50 ft for various throttle settings and Fig. 4.4 shows the effect of speed on the noise at throttle 8. Figure 4.5 shows a similar trace for an unpowered pass-by at 38 mph. This last trace is almost identical

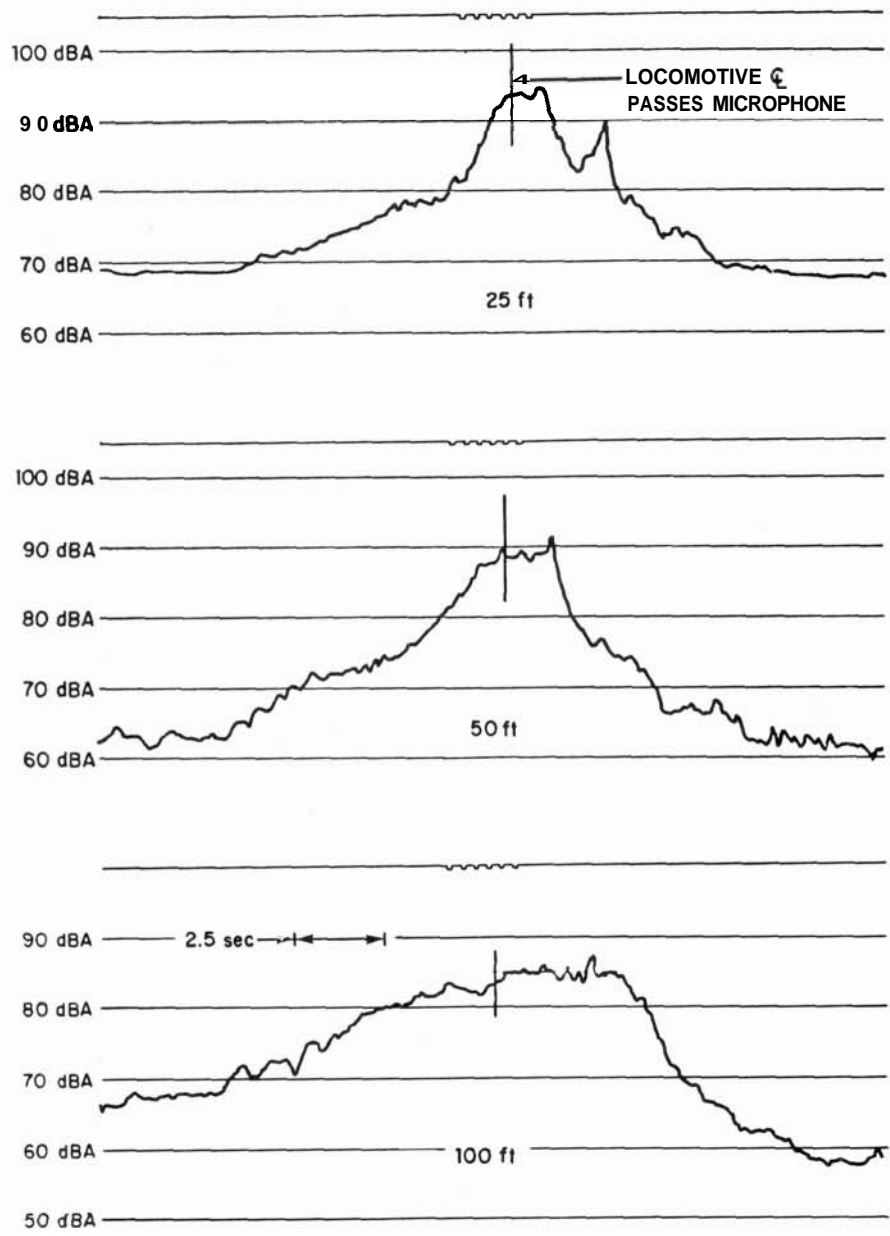

FIG. 4.2. LOCOMOTIVE PASS-BY AT 36 MPH (THROTTLE 8) (WEST).

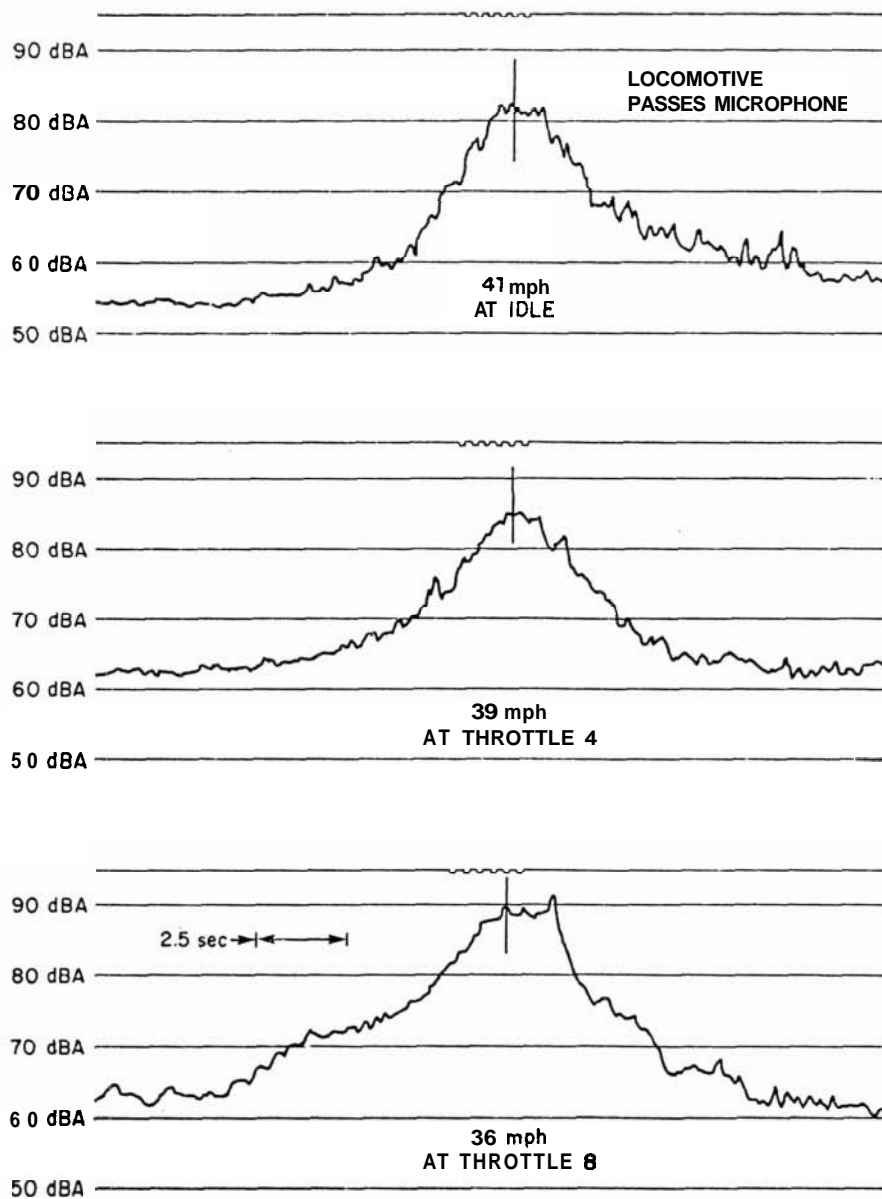

FIG. 4.3. LOCOMOTIVE PASS-BY AT 50 FT (WEST).

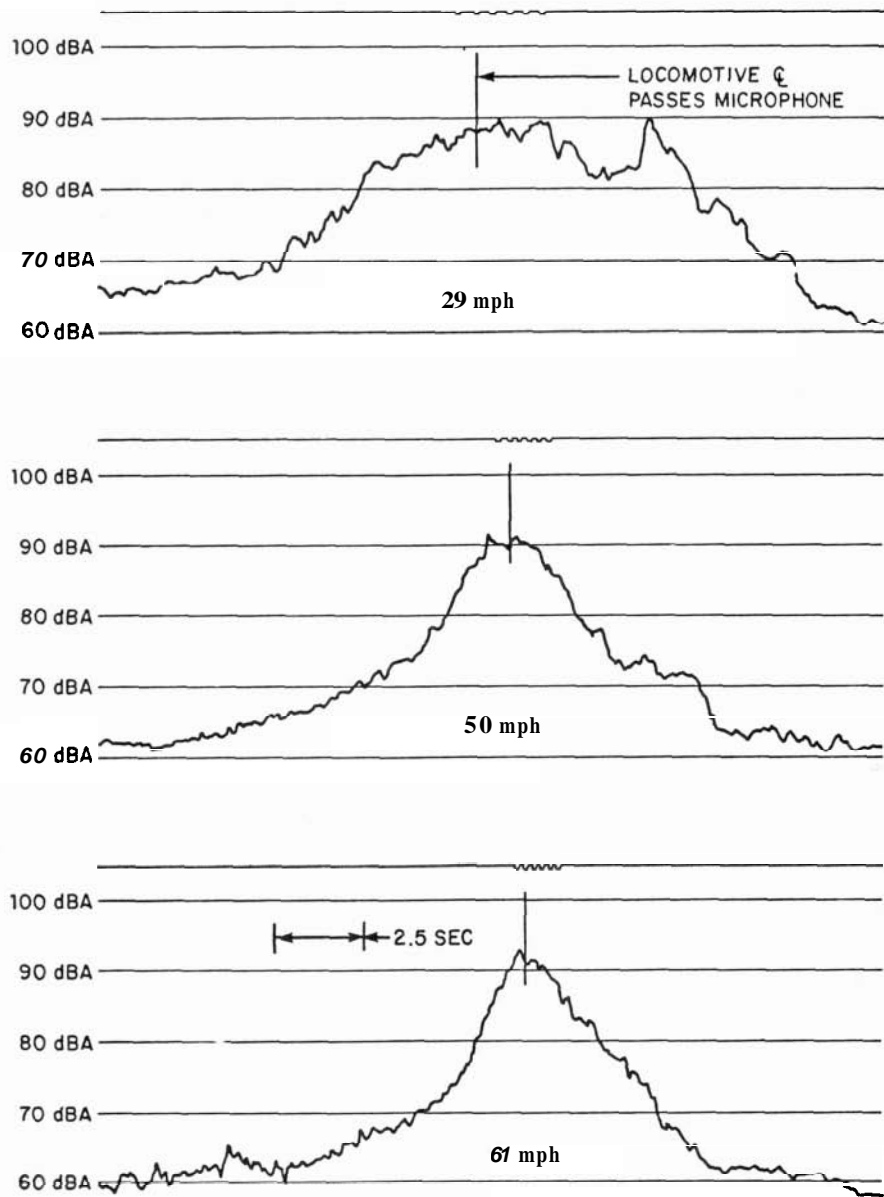

FIG. 4.4. LOCOMOTIVE PASS-BY AT 50 FT (THROTTLE 8, WEST).

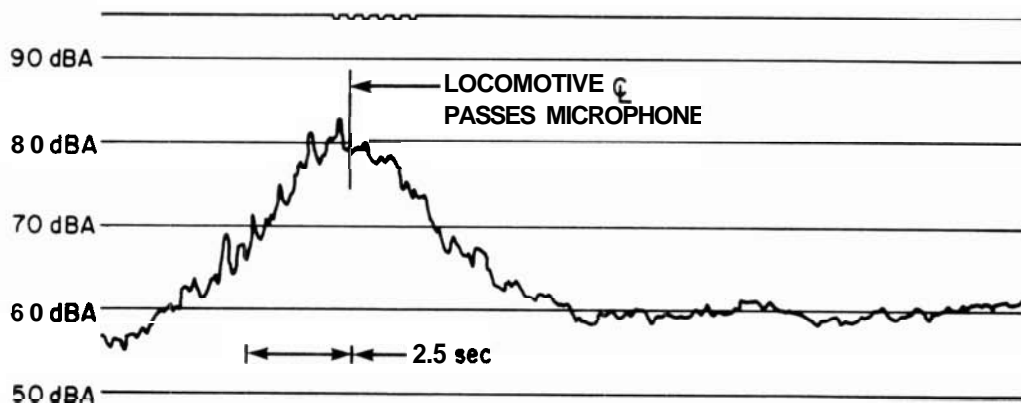

FIG. 4.5. COAST-BY NOISE AT 50 FT (38 MPH).

to the idle trace in Fig. 4.3, indicating that the latter, as expected, is primarily wheel/rail noise.

## 4.2 Stationary Tests

### 4.2.1 Baseline tests

The baseline tests were performed to obtain detailed information on the noise emitted by the locomotive at a number of locations and at a number of throttle settings. This information is used to compare the noise emitted in a stationary test with that measured in a pass-by test and to check the results of the diagnostic measurements in Sec. 4.2.3. It also shows any directional characteristics and lack of axial symmetry in the noise from the locomotive as well as effects of ground reflections. Finally, since two sets of baseline data for the same locomotive at the same site are available - one taken in July, and one in August - the reproducibility of the data can be examined.

### *Test Procedure*

The microphone array and instrumentation setup are described in Sec. 3.2.1. The load cell was located on one side of the locomotive, and noise measurements were made on the other side using the microphone array of Fig. 3.5. The locomotive was then turned around and the measurements were repeated. The throttle settings examined were idle throttle <sup>4</sup> and throttle 8, under full load. For all throttle settings, all three radiator cooling fans were operating. All data were recorded in the field and later analyzed in the laboratory with a General Radio 1/3-octave band real-time analyzer.

### *Results*

The overall A-weighted sound pressure levels measured in July at the 100 ft microphone locations and shown in Fig. 4.6 give an indication of the directivity pattern of the noise from the locomotive. The A-weighted 1/3-octave band sound pressure levels measured at all locations in Fig. 3.4 are shown in Appendix A, Figs. A.1 through A.27. The noise spectra measured in July\* at the locations on the right-hand side of the locomotive are compared in each figure with the spectra (taken after turning the locomotive around) at the corresponding symmetric position on the left-hand side of the locomotive. Also shown, to allow examination of the reproducibility of the noise data, are baseline data taken on the right-hand side of the locomotive in early August<sup>†</sup> (after the locomotive had been in line-haul service for nearly a month). Finally, to give an indication of the signal-to-noise ratio in

---

\*These data were recorded on the Lockheed tape recorder.

†These data were recorded on the Nagra tape recorder. No August baseline data were obtained at locations 8 and 9.



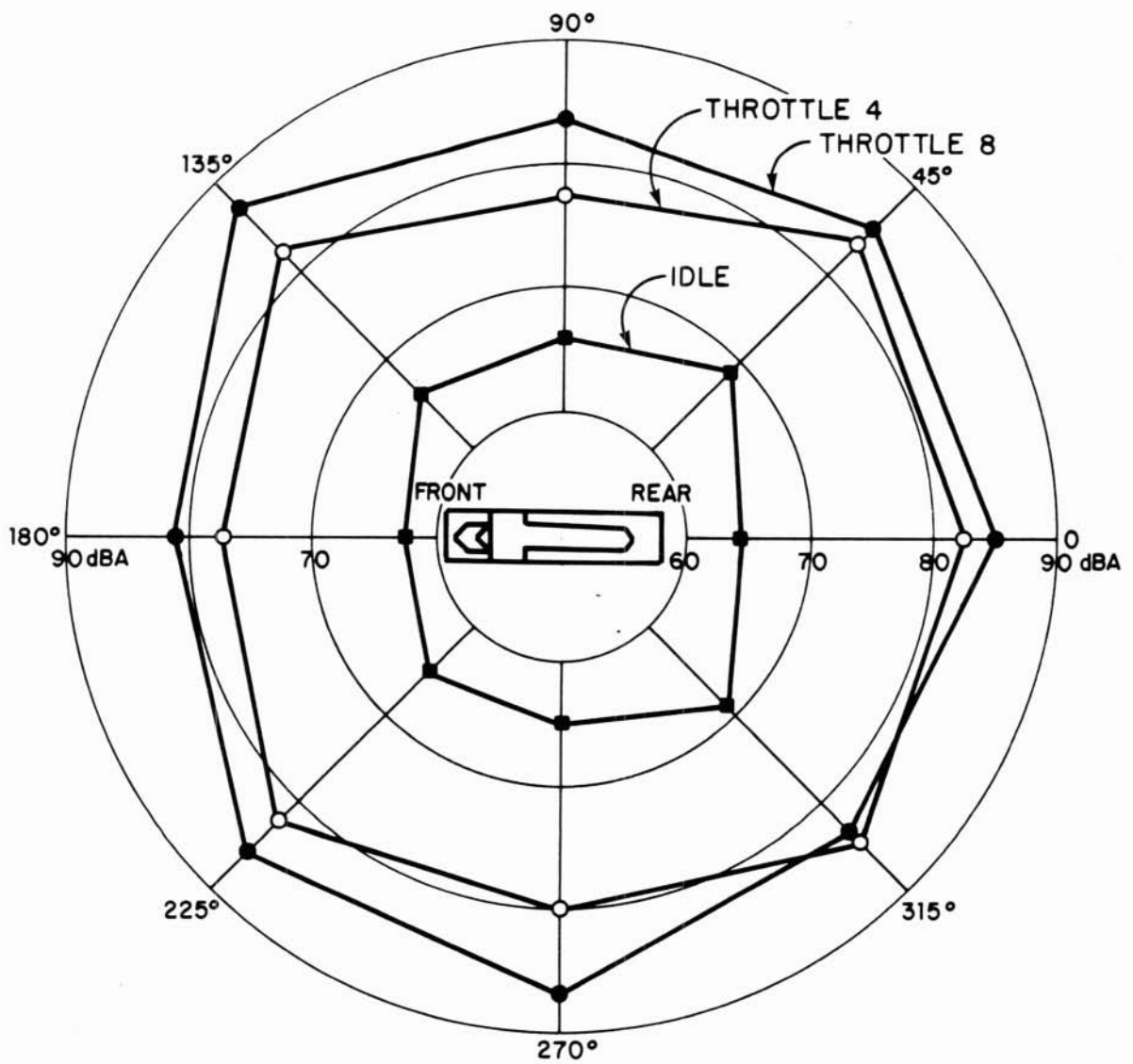

FIG. 4.6. DIRECTIVITY OF LOCOMOTIVE NOISE.

these data, we have shown the results of the quieted baseline tests run during the diagnostic tests (described in detail in Sec. 4.2.3). These last data can, in a sense, be thought of as background noise since they are measurements obtained after turning off, or quieting to the fullest extent possible, every noise source on the locomotive. These spectra contain residual locomotive noise, load cell noise, and background noise from other sources such as wind and traffic. The overall noise levels are summarized in Table 4.4.

The range of background noise, recorded with the locomotive not running, at microphone locations 3 and 6 throughout one day in July was 50 - 62 dBA. One-third octave band spectra showing this range are shown in Appendix A, Fig. A.28. These measurements indicate that when the locomotive is at idle, the quieted baseline tests are measuring primarily background noise at the higher frequencies. Background noise is less of a problem at the higher throttle settings, where the quieted baseline spectra are generally well above the background spectra. When the quieted baseline spectra are compared with the baseline spectra, it becomes apparent that, at idle, the baseline data at microphone locations 1, 4, and 5 are questionable except at low frequency.

At throttle 4, the data at location 1 above about 1000 Hz and at location 5 above about 500 Hz indicate that either unquieted sources inside the locomotive or other extraneous sources are contaminating the data. Particularly suspicious is the fact that peaks in the quieted baseline data can be distinguished in the 630- and 1250-Hz bands. These same bands stand out in load cell noise spectra at throttle 4, suggesting that the load cell is contaminating the data at these two locations.

At throttle 8, a similar contamination can be seen in the data at location 1 above 1600 Hz and at location 5 above 800 Hz.

TABLE 4.4. OVERALL BASELINE LOCOMOTIVE NOISE LEVELS (dBA) WITH 3 COOLING FANS RUNNING.

IDLE

Measurement	Location								
	1	2	3	4	5	6	7	8	9
July Measurements Right Side	64.5	68	66	66	62.5	71	73	64.5	71.5
August Measurements Right Side	65.5	69	67	64	63	72.5	74	-	-
July Measurements Left Side	-	69	65.5	65	-	71	71	65.5	72
Fully Quieted Right Side	60.5	59.5	57	57	55	64	67.5	-	-

THROTTLE 4  
FULLY LOADED

Measurement	Location								
	1	2	3	4	5	6	7	8	9
July Measurements Right Side	82.5	83.5	77.5	82	77.5	82.5	85.5	77	83
August Measurements Right Side	79	83	78	79	78	81.5	84	-	-
July Measurements Left Side	-	84	80	82	-	83	85	77.5	83
Fully Quieted Right Side	66	67	64	63.5	64	71	74	-	-

THROTTLE 8  
FULLY LOADED

Measurement	Location								
	1	2	3	4	5	6	7	8	9
July Measurements Right Side	85	85	83.5	87	81	86.5	96	86	94
August Measurements Right Side	84	87.5	86	85	81	91.5	95	-	-
July Measurements Left Side	-	83.5	86.5	85.5	-	89.5	96	85.5	94
Fully Quieted Right Side	72	76	72.5	74	72.5	78	81.5	-	-

Again, the spectral peaks in the quieted baseline data at 1000 and 2000 Hz can be attributed to the load cell when the locomotive is operated at throttle 8. Contamination of the data at locations 1 and 5 is not unexpected, since these locations (at the back and front of the locomotive, respectively) are not shielded from the load cell by the locomotive in any way. At the same time, the lowest locomotive noise levels are measured at those two locations.

The peaks in the spectra at 4000 Hz at idle, 8000 Hz at throttle 4, and 12,500 Hz at throttle 8 (not shown in Figs. A.1 - A.27) are believed to be associated with the turbocharger.

For the data at all locations other than 1 and 5, in Appendix A, the spectra at symmetric locations on both sides of the locomotive are compared and those regions where these spectra are not the same are shaded to indicate any differences clearly. Components of the SD40-2 locomotive are arranged quite symmetrically about its axis. Three asymmetries only might affect noise:

- a. The engine intake is located on the right side of the air compartment.
- b. The traction motor blower is located on the left side of the air compartment.
- c. The traction motor blower exhausts to the left in the traction motors in the cab truck and to the right in the hood truck.

These asymmetries would not be expected to introduce any significant asymmetry in the noise signature because, as is shown in Sec. 4.2.3, the traction motor blower and intake are not dominant sources. But, as is clear in Figs. A.4 to A.17 in Appendix A, many locations show considerable difference in the noise spectra

on the two sides of the locomotive. The widest spread is at throttle 8 at locations 3 and 6 (see Table 4.4), where there is a 3-dBA difference in the overall levels on the two sides of the locomotive. These differences in the spectral noise levels on the two sides of the locomotive do not appear to be caused by any lack of axial symmetry in the noise from locomotive, but rather by problems with reproducibility of the noise spectra. This fact becomes more apparent when baseline data taken in July on the right-hand side of the locomotive are compared in Table 4.4 with the same data taken one month later in August. The differences are similar to the differences observed between symmetric locations on each side of the locomotive during the July baseline tests. These problems with reproducibility appear to be associated with changes in wind and temperature gradients at the test site.

During the July baseline test, the wind was blowing in a direction that would correspond to a line pointing from location 4 to location 1. Though the speed never exceeded 15 mph, it was highly variable, ranging anywhere from calm to 15 mph during any given measurement. In August, the wind was blowing along a line from the center of the locomotive to location 3 with the same variability in speed as in July. Changing wind speeds changed the velocity and temperature gradients, which in turn affected the refraction of the sound as it propagated from the locomotive to the microphone. Ground reflections and any shielding afforded by the locomotive hood of the sound from exhaust cooling fans, etc., were all affected. As a result, there appears to be uncertainty in the measurements of the spectral and overall noise levels from the locomotive. This uncertainty has considerable implications for the diagnostic measurements discussed in Sec.

4.2.3 and for any measurement scheme to quantify the noise from a locomotive.\*

It should be noted, also, that major peaks in the data in Appendix A do not occur at the firing frequencies (160 Hz at throttle 4 and 240 Hz at throttle \*), but at one-half of the firing frequency at these throttle settings. This is not an uncommon phenomenon. In fact it is possible for this major peak to occur at any multiple of the rotation rate, i.e., down to 1/16 of the firing frequency. A similar peak in the data is observed at idle at 40 Hz instead of at the firing frequency of 80 Hz. In the A-weighted spectra this has been found to be well below the 80 Hz peak, however, and no significant errors will be introduced by reporting data only at 63 Hz and above.†

It is also apparent from comparison of the July and August data that the Lockheed tape recorder used in July gives consistently higher spectral levels in the 63-Hz band than the Nagra tape recorder used in August. This band was compensated during playback to adjust for the rapid roll off of the Lockheed below 80 Hz. Considering how rapidly the Lockheed rolls off some errors in compensation are to be expected however the errors observed here are modest.

---

\*It should be noted that the variability discussed here can be heard by persons standing at some distance from the locomotive and that it is distinct from variations in noise associated with small changes in engine speed. The latter can also be heard, but are much more regular and of much shorter periods.

†The Lockheed tape recorder cuts off below approximately 63 Hz, but the Nagra recorder is still reasonably flat at 40 Hz. The 40-Hz peak in the idle spectra was observed on the Nagra recorder to be 6 to 11 dB below the peak at 80 Hz.

#### 4.2.2 "Throttle wipe" tests

##### *Test Procedure*

The locomotive was connected to the load cell and started. Noise measurements were obtained with the locomotive both loaded and unloaded. The locomotive was stepped from one throttle setting to another, holding each setting for about 5 sec and advancing from idle up to throttle 8. The locomotive was then switched abruptly from one throttle to another in accordance with the AAR smoke-test procedure. The throttle sequence was 1 → 4, 4 → 8, 8 → 6, 6 → 8, 8 → idle, idle → 8. The outputs of two microphones at 100 ft from the center of the locomotive, corresponding to locations 3 and 4 in Fig. 3.4, were recorded. The recorded signal was then filtered through an A-weighting network and its level plotted on a graphic level recorder. The results are shown in Figs. 4.4 through 4.14.

Throttle wipe tests were performed to determine whether there was an increase or overshoot in noise when throttle settings were changed and particularly to determine if throttle 8 under load is in fact the loudest setting. When the locomotive was unloaded, the noise level increased steadily from one throttle setting to another. The one exception was at location 4 (unloaded), where throttle 4 was louder than throttle 5 (Fig. 4.9). In general there were no overshoots with abrupt throttle changes except at location 3 (Fig. 4.14) where changing from throttle 6 to 8 there was about a 2 dBA overshoot that was not seen at location 4. Wind-caused fluctuations in sound level were found during all testing. Note that in Fig. 4.10 (the dashed line) a brief portion of data was lost during the shift from throttle 8 to 6. There is also a very sharp spike in the data in Fig. 4.10 and 4.14 when changing from throttle 8 to idle. This is believed to

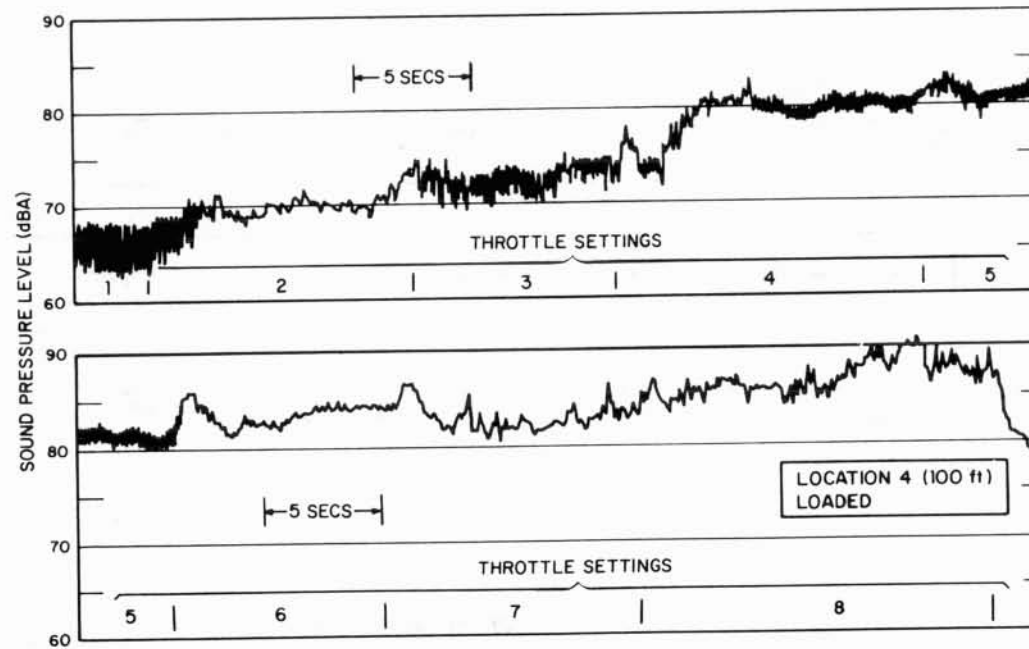

FIG. 4.7. NOISE FROM INDIVIDUAL THROTTLE SETTINGS, LOCATION 4, LOADED.



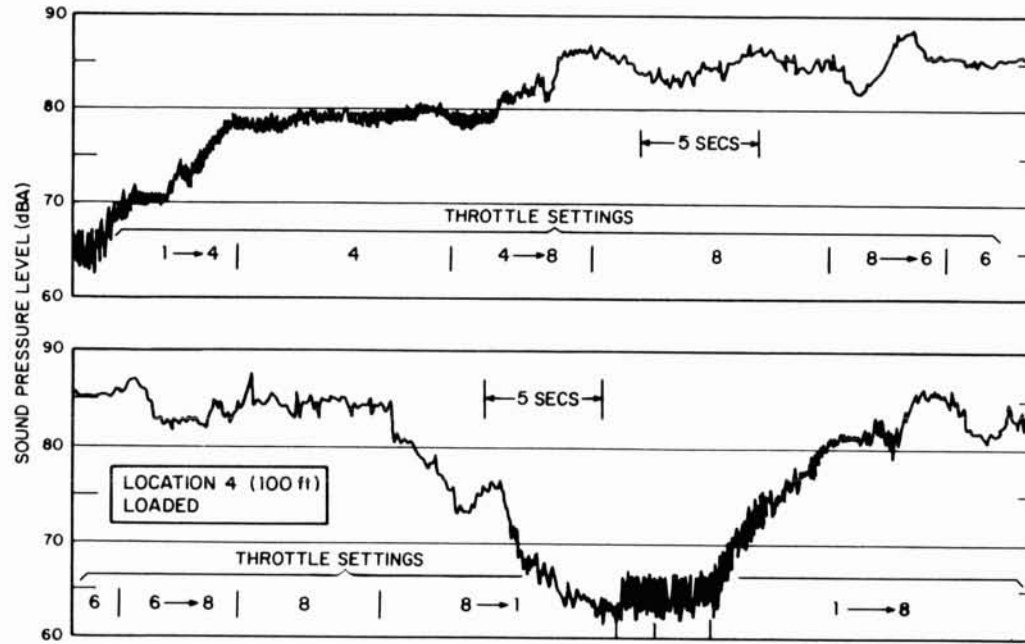

FIG. 4.8. NOISE DURING THROTTLE WIPE TESTS, LOCATION 4, LOADED.

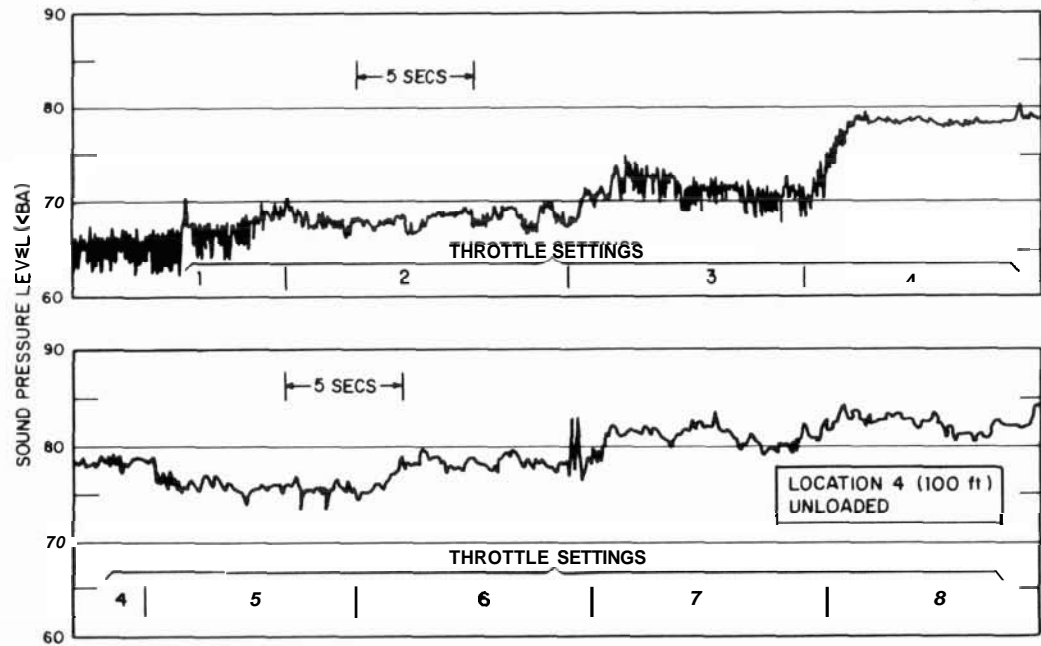

FIG. 4.9 NOISE FROM INDIVIDUAL THROTTLE SETTINGS, LOCATION 4, UNLOADED.

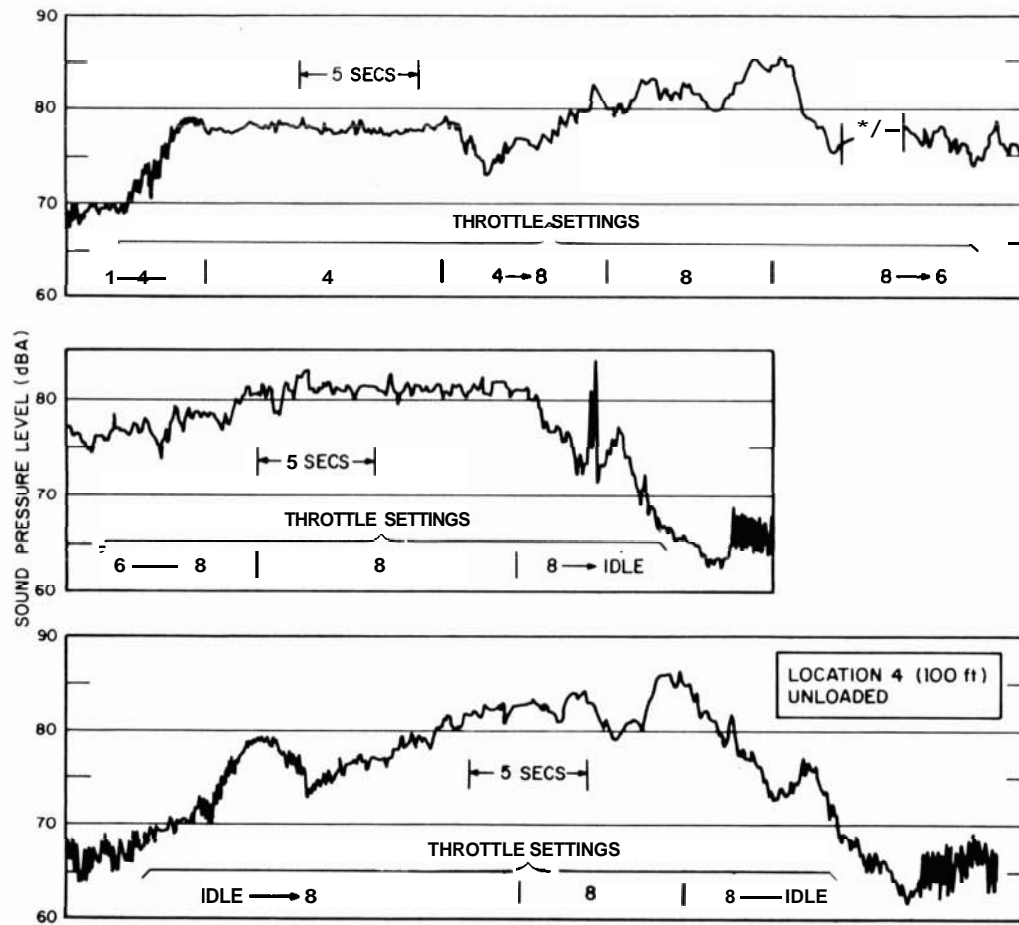

FIG. 4.10. NOISE DURING "THROTTLE WIPE" TESTS, LOCATION 4, UNLOADED.

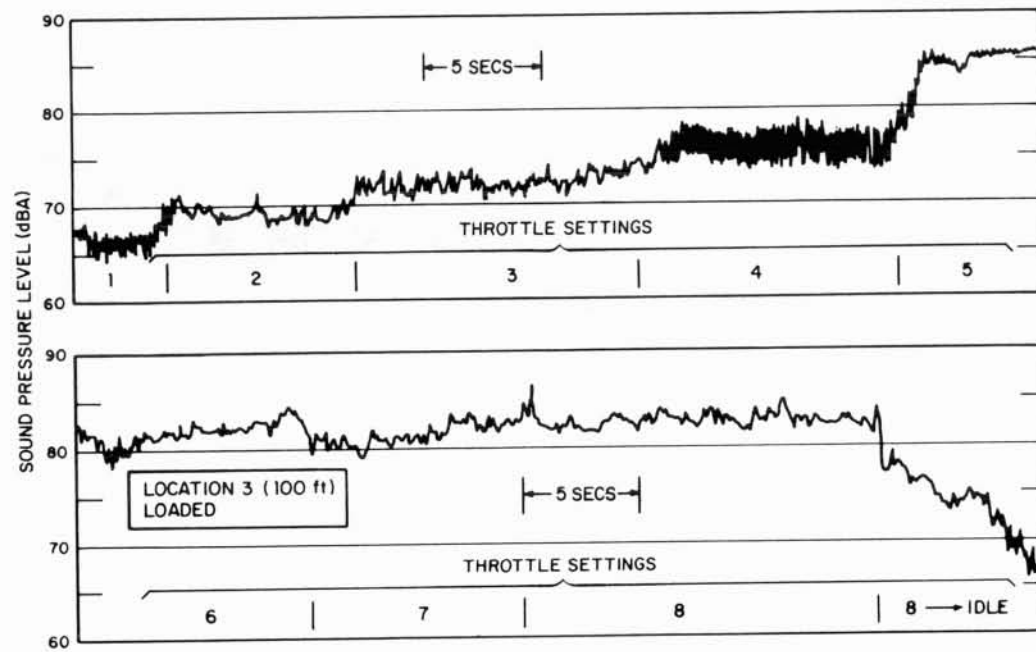

FIG. 4.11. NOISE FROM INDIVIDUAL THROTTLE SETTINGS, LOCATION 3, LOADED.

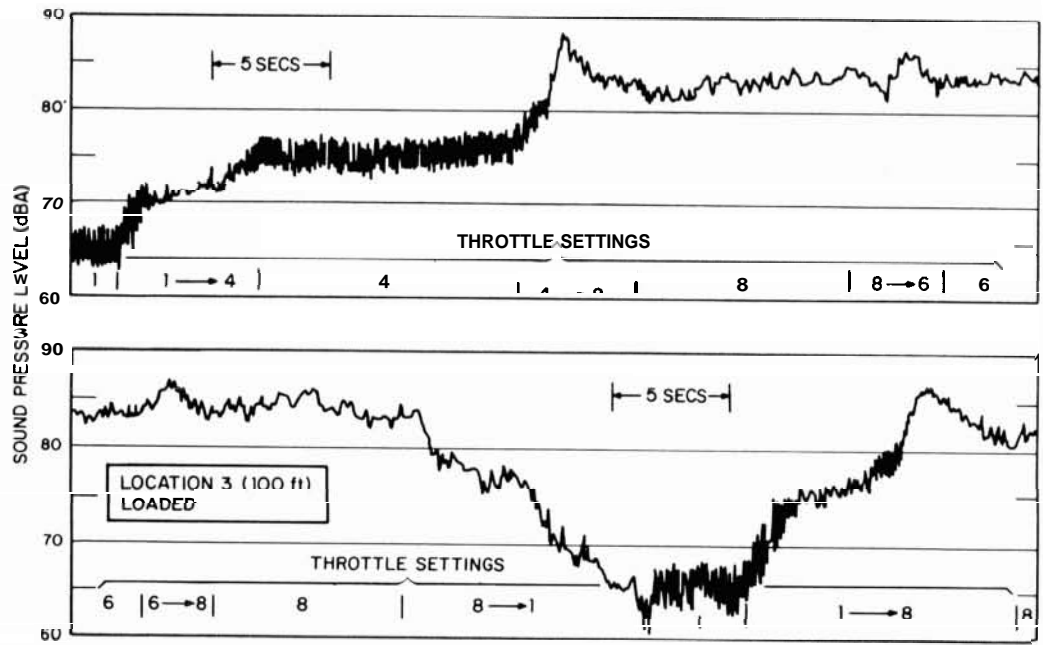

FIG. 4.12. NOISE DURING "THROTTLE WIPE" TESTS, LOCATION 3, LOADED.

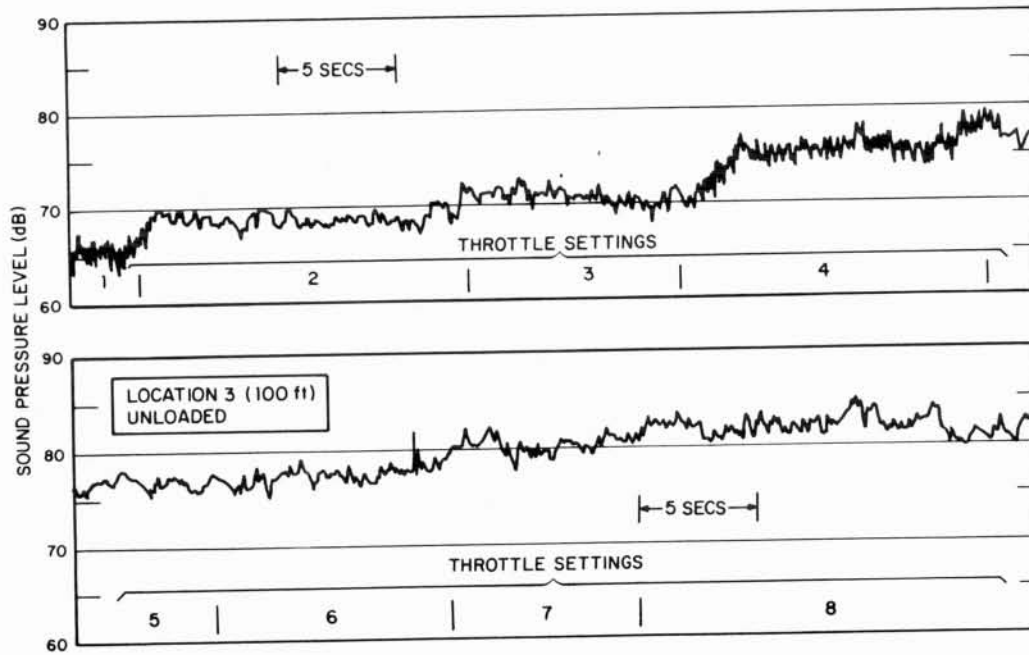

FIG. 4.13. NOISE FROM INDIVIDUAL THROTTLE SETTINGS, LOCATION 3, UNLOADED.

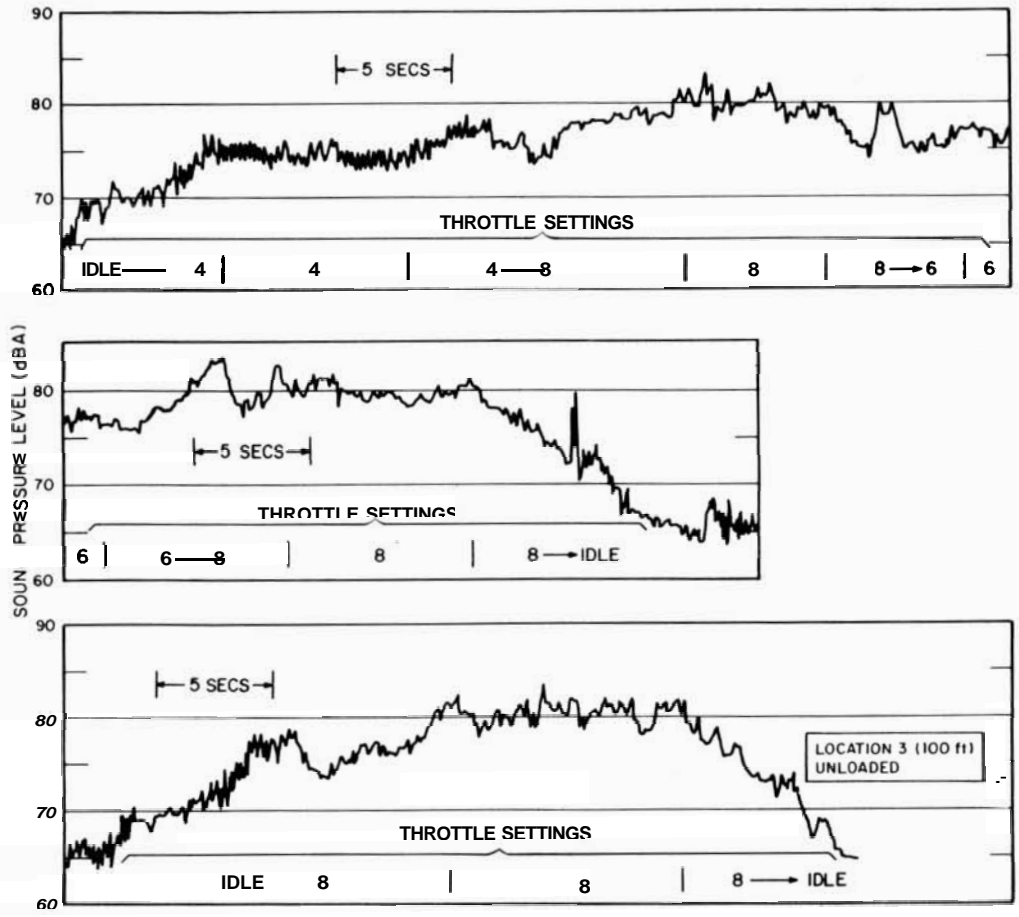

FIG. 4.14. NOISE DURING "THROTTLE WIPE" TESTS, LOCATION 3, UNLOADED

be associated with an abrupt release of air from the compressed air system on the locomotive.

When the locomotive was under load, an overshoot could be seen on entering or leaving throttle 6 (Figs. 4.7, 4.8, 4.11, and 2. Levels 2 to 3 dBA higher than throttle 8 could be attained at this point. In addition an overshoot of almost 5 dBA can be seen at location 3 when changing from throttle 4 to 8 (Fig. 4.12). At location 4 however, it is not clear that any overshoot has occurred for the same throttle change (Fig. 4.8). The most remarkable anomaly in the data can be seen in Fig. 4.11: throttle 5, under load, produces at least 2 dBA more noise than any other throttle setting at location 3. No similar anomaly can be seen at location 4. Whether the anomaly is caused by wind or whether it is a real indication that throttle 5 is very noisy is, at present, uncertain.

Comparing the noise generated with the locomotive loaded and unloaded we find unloaded noise levels to be lower generally than loaded noise levels.

#### 4.2.3 Diagnostic tests

A series of detailed diagnostic tests were performed to determine the contribution of various locomotive noise sources to the total noise signature. Such information is essential to an understanding of the noise generation in a locomotive; no cost-effective noise control approach can be formulated without it.

Sources identified as potential major contributors to the noise signature were:

- a. engine exhaust
- b. radiator cooling fans



- c. engine/main alternator
- d. engine intake
- e. traction motor and generator blowers
- f. dust bin blower
- g. compressor.

Though the airborne path of noise was our primary study, we also examined the structureborne path from the engine, main alternator, compressor, and radiator cooling fans. In the airborne path, noise sources in the locomotive radiate noise directly to the wayside with some loss, in some cases, due to the presence of the hood. In the structureborne path, sources such as the engine main alternator, compressor, cooling fans, etc., excite the structure of the locomotive causing vibration. The locomotive structure then radiates sound to the wayside.

### *Test Procedure*

The following procedure was used to obtain the contributions of each of the above sources to the overall locomotive noise signature. We first quieted, or shut down, each major source. We then removed the noise control treatment, or powered up each source independently. In those cases in which the noise increased at the seven microphone locations in Fig. 3.9, the contribution of that source could be estimated from the increase. Noise increased in the cases of engine exhaust and radiator cooling fans. When no increase, or only a negligible increase, in noise was observed, measurements of the noise near the source were extrapolated to the locations of interest around the locomotive through the use of transfer functions measured as described in Appendix C. These transfer functions related the noise near the source to the noise at the locations of interest. This latter approach

was used for the engine/main alternator, traction motor blowers, dust bin blower, engine intake, and compressor. The structure-borne contribution was determined by using a similar transfer function approach, described in Appendix D. Vibration levels measured at the engine, main alternator, compressor, and cooling fan, etc., mounting points were used with the transfer functions to estimate the structureborne contribution.

Treatments applied to quiet the locomotive fully were:

- a. An industrial exhaust silencer
- b. Radiator cooling fans shut down
- c. Compressor shut down\*
- d. A 3-in.-thick layer of fiberglass, applied to the interior of the hood on all walls and doors
- e. Hood access doors taped
- f. Dust bin blower shut down
- g. Traction motor blower inlet sealed with 1 lb/sq ft lead
- h. Silencers installed on the air compartment intake vents. (Fiberglass lined 3/4-in. plywood ducts.)

Figures 4.15 and 4.16 show the locomotive in the fully quieted configuration. The muffler, a Kittell Yodel TBU22 exhaust silencer, is supported by a fork lift on a flat car. The fork lift was blocked up and its engine shut down during all noise tests. The ducting fits directly over the exhaust stack, as shown in Fig. 4.17.<sup>t</sup>

---

\*A by-pass valve was opened to prevent the compressor from pumping. Since the compressor was mechanically connected to the engine it was rotating whenever the engine was running.

<sup>†</sup>The muffler system was designed by the Donaldson Company for a parallel program and was provided to this program on a rental basis.

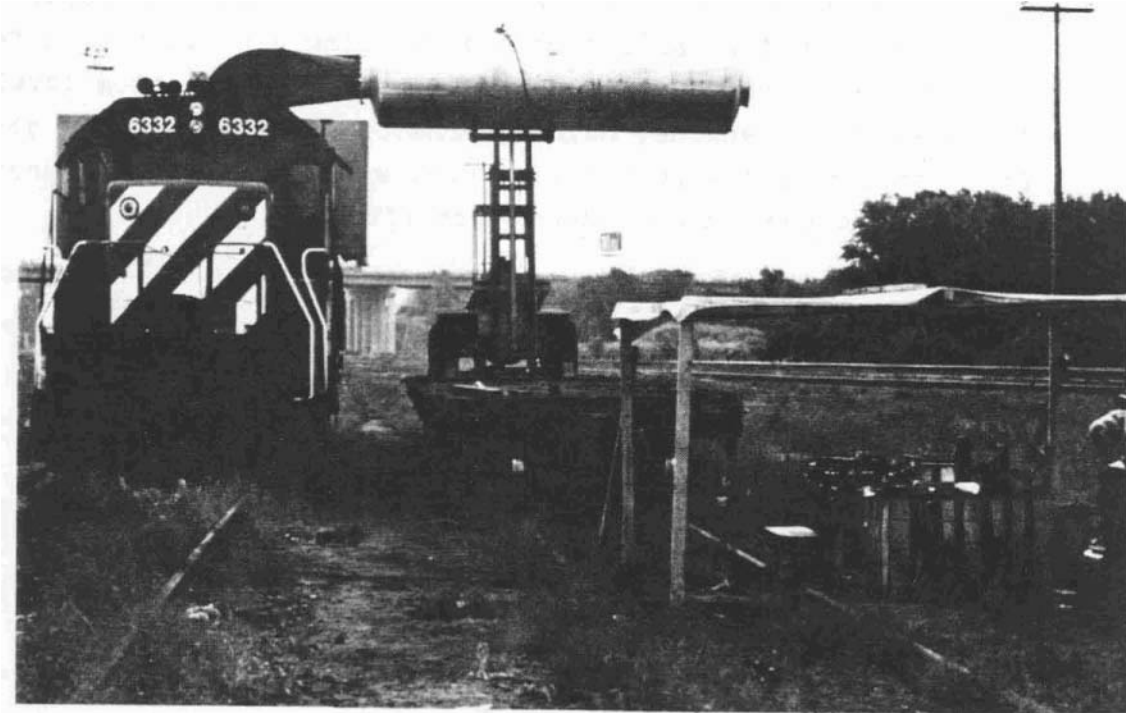

FIG. 4.15. FULLY QUIETED LOCOMOTIVE, LOOKING EAST.

Radiator cooling fans were shut down through an electrical switching arrangement set up in the cab. This arrangement allowed for any fan or combination of fans to be shut down or powered up at will. The engine temperature was watched carefully, and testing was terminated when the temperature exceeded safe limits. All fans were then powered up, and when the engine temperature was lowered to safe limits, the fans were shut down and testing was resumed.

The air storage tanks were fully pressurized prior to testing to ensure that the compressor would not operate during the



FIG. 4.16. FULLY QUIETED LOCOMOTIVE, LOOKING SOUTHWEST.

tests. This provided a significant period of time for testing during which the compressor was rotating at engine speed, but not loaded and therefore not a significant noise source.

The dust bin blower was disconnected from the electrical system during testing to eliminate it as a noise source.

A 3-in.-thick blanket of fiberglass insulation was taped to the doors and walls inside the hood. In addition, the doors and latches were sealed with duct tape; Fig. 4.16 shows the locomotive so treated. Also shown in Fig. 4.16 is one of the two inlet silencers installed on the air compartment inlet vents. These silencers, which can be seen in Fig. 4.15 behind the cab on each side of the locomotive, were simply large boxes made of 3/4-in. plywood lined with 3 in. of fiberglass insulation and opened at the bottom.

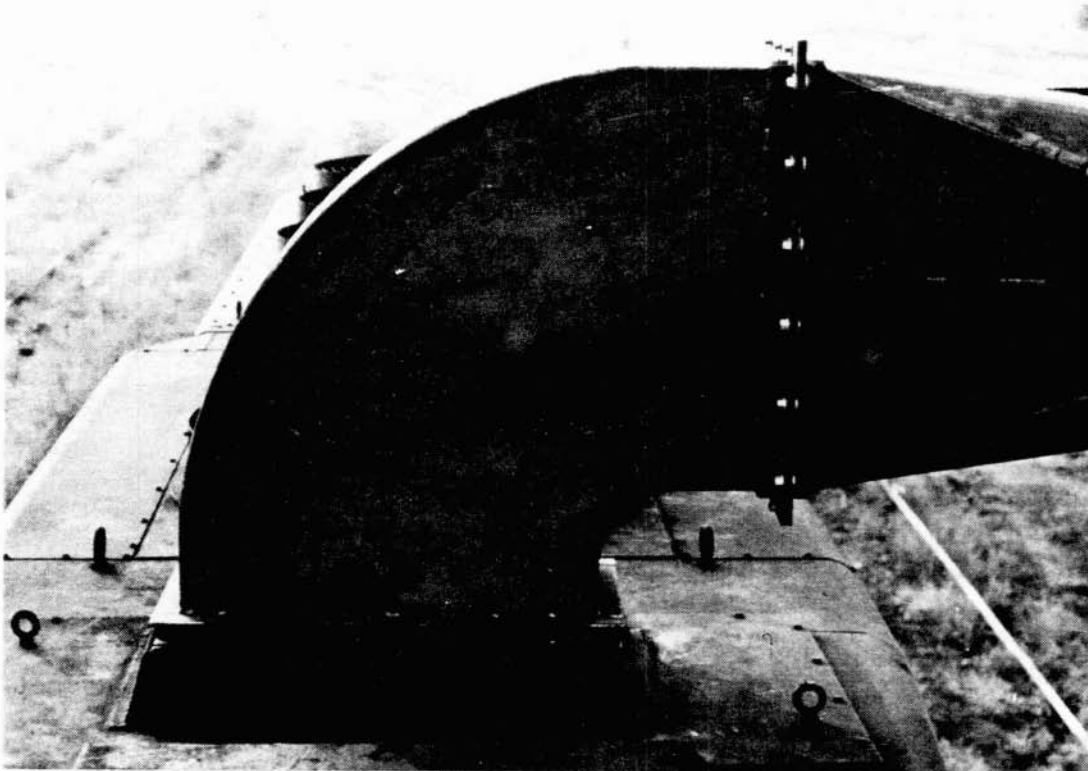

FIG. 4.17. LOCOMOTIVE EXHAUST STACK TO MUFFLER TRANSITION COUPLING.

Finally, to silence the traction motor blowers, we taped a sheet of 1-lb/sq-ft lead to the inlet, making an air-tight seal, an approach suggested by EMD that proved effective.

### *Results*

The results of the diagnostic measurements are present in Appendix B and summarized for the four major sources in Table 4.5. As shown in that table the sum of the four sources for each throttle setting and microphone location agrees well with the

TABLE 4.5. SUMMARY OF DIAGNOSTIC TESTS.

IDLE

Source	Location						
	1	2	3	4	5	6	7
Exhaust	-	65	66	65	61.5	70.5	71
Fan	-	-	59	-	-	62	65
Engine	-	60	62	59.5	52	69	73.5
TM Blower	-	46	47	47	-	51	59
Overall Measured Noise	-	69	67	66	62.5	72.5	74
Sum of 4 Sources	-	-	68	-	-	73	75.5

THROTTLE 4

Source	Location						
	1	2	3	4	5	6	7
Exhaust	-	81	78	79	76	82.5	82
Fan	74	70	70	68.5	-	75	80
Engine	63.5	66	67	63.5	55	70.5	78
TM Blower	50	61.5	64	61.5	52.5	67.5	74
Overall Measured Noise	79	83	78	82	78.5	81.5	84
Sum of 4 sources	-	81.5	79	79.5	-	83.5	85.5

THROTTLE 8

Source	Location						
	1	2	3	4	5	6	7
Exhaust	-	84.5	84	88	81.5	87.5	90
Fan	77	80.5	83	81.5	-	89	92
Engine	67	67	66.5	66.5	57.5	73	77
TM Blower	63	72	75	72.5	62	78	87
Overall Measured Noise	83	87.5	86	85	81	91.5	95
Sum of 4 Sources	-	86	87	89	-	90	95

overall measured noise from the baseline test. In the following pages, we will discuss all the noise sources considered in the measurement program. The data at locations 1 and 5 are valid over only a limited frequency range, and results are presented only in that range. No data are presented at location 1 at idle.

The *quieted baseline measurements* refer to the noise measurements made when the locomotive was in its quietest condition, i.e., using all the noise-reducing treatments and component shutdowns described previously. The resulting spectra have already been presented in comparison with baseline data in Sec. 4.2.1. A considerable reduction in noise was achieved. This reduction in noise has significant implications for the success of the diagnostic measurements, but of course the type of noise control treatment used would not be practical for an operating locomotive.

The *exhaust source spectra* are shown in Appendix B at all locations except location 1; distortion in the microphone signal at that location during this test prevented use of the data. The exhaust source spectra were obtained by measuring the noise from the fully quieted locomotive with the exhaust muffler removed. The difference between these noise spectra and the quieted baseline noise spectra are the engine exhaust source spectra. Gaps in the exhaust source spectra indicate those frequency bands where the unmuffled noise levels were less than 2 dB higher than the quieted baseline levels. Exhaust is the primary source at low and high frequency.

The *cooling fan source spectra* were obtained by turning all three cooling fans on with the locomotive in the fully quieted condition and running unloaded. The difference between the noise spectra with the cooling fans running and the fans shut off yielded the fan source spectra. Gaps in the spectra indicate

frequency bands where there was insufficient cooling fan noise to overcome the noise from other sources. Gaps are particularly prominent at idle where fan noise levels were quite low. Fan noise is a major source at throttles 4 and 8, primarily in the mid-frequency range.

Since operation with all three cooling fans running is rare, microphone location 3 fan source spectra for one, two, and three fans operating are shown in Appendix B, Figs. B-21 and B-22 for throttles 4 and 8, respectively. Fan source levels were too low to produce a similar plot for idle. These measurements are summarized in Table 4.6.

TABLE 4.6. FAN SOURCE LEVELS AT LOCATION 3.

Number of Fans	Throttle 4 dBA	Throttle 8 dBA
1	64	76
2	67	81
3	70	83

The *engine/alternator source spectra* were obtained first by untaping the doors, removing the fiberglass from the interior of the hood, and measuring the change in noise at full load, from the fully quieted configuration. This procedure resulted in up to a 6.5-dB(A) increase in noise at some locations. Despite this significant increase in noise at a number of throttle settings and microphone locations, the resulting source spectra were incomplete, i.e., in many 1/3-octave bands the noise did not increase enough to estimate the engine/alternator source strength. Therefore, we measured the noise under the hood at four locations



around the engine and alternator\*, averaged these noise measurements, and extrapolated these measurements to the seven locations of interest using transfer functions measured as described in Appendix A. In general, estimates based on the transfer functions agreed well with the estimates based on the direct measurement of the change in noise. In a few cases, the directly measured spectra were higher than those derived by using the underhood measurements and transfer functions. In all cases we have shown, the transfer functions result in the relevant figure. We have done this for several reasons: transfer functions have provided estimates at other throttle settings that agree with direct measurements, and the underhood engine levels have provided similar confirmed results at other locations. Finally, the resulting estimate of the spectra are consistent with the spectra measured at other locations. The few discrepancies between the direct measurements and the transfer function estimates is believed to result from the fact that changes in noise observed after removing the fiberglass and door seals are caused in some cases not by the changed noise treatments but by changes in wind and temperature gradients as described in Sec. 4.2.1.

The label, engine/alternator, is to some degree an oversimplification since the noise from many sources present under the hood (dc auxiliary generator, generator blower, etc.) would be enhanced by removal of the fiberglass and door seals and would be included in any underhood measurements. However, the engine and main alternator are the largest, and potentially the noisest, components under the hood; hence, we attribute these source spectra to them. They are most important at idle in the mid frequencies.

---

\*The locomotive was in the fully quieted condition except that the fiberglass and door seals were removed.

The *traction motor blower source spectra* were obtained with the locomotive treated as for the engine/alternator, except that both the intake silencers\* and the lead seal from the traction motor blower intake were removed. The increase in noise observed (with the locomotive running unloaded) after removing the seal on the inlet of the traction motor blower was attributed to that blower. An increase in noise was generally observed at all locations, except at idle, but the change was not large enough to provide a reliable measure of the traction motor blower source strength. As a result, the source spectra reported in Appendix B, Figs. B.1 to B.20 are based on a transfer function approach that seeks to extrapolate the levels in the air compartment, attributable to the traction motor blower, to the seven microphone locations of interest.

At throttle 8 the traction motor blower requires approximately 122 hp whereas the generator blower requires only approximately 20 hp. Unsealing the traction motor blower increases air compartment levels by 2 dBA at idle, 8.5 dBA at throttle 4 (no load), and 12 dBA at throttle 8 (no load), indicating that the traction motor blower is the major source in the air compartment, with the possible exception of operation at idle.

The spectral levels estimated at the seven microphone locations (details are given in Appendix C) generally agreed with estimates of those levels based on the change in noise at the seven locations when the seal was removed. In a few instances,<sup>†</sup> as with the engine/alternator source spectra, the estimates of

---

\*No increase in noise at the seven locations around the locomotive was observed.

<sup>†</sup>Throttle 4, location 1 direction measurements were 6 to 12 dB high, and throttle 4, location 5 direct measurements were from 1 to 11 dB high.

the traction motor blower source spectra that were based on direct measurements of the change in noise at the seven locations of interest gave higher levels than the estimates based on the transfer functions. These discrepancies may have resulted from the fact that some of the observed changes in the measured noise were caused not by removal of the inlet seal but, at least in part, by the same wind and temperature gradient changes that caused the changes in the baseline spectra of Sec. 4.2.1.

The compressor was found to be a very weak source. It could be heard clearly only if loaded with the engine at idle. Measurements made in the engine compartment approximately 2 ft above the compressor, first with the compressor pumping and, second, not pumping, yielded only a few bands where the compressor could be heard. A transfer function approach (see Appendix A) was used to extrapolate these measurements to the seven locations of interest. For completeness and for provision of an upper bound estimate of compressor source spectra, the noise spectra measured near the compressor where no change could be noted whether the compressor was pumping or not were also extrapolated to the seven locations of interest. These are called "compressor upper bound" in Appendix B.

The *dust bin blower*, a minor source, cannot be heard at the farfield microphone location. To obtain its source spectra transfer functions (see Appendix C) were used to extrapolate nearfield measurements to the seven locations of interest. Measurements were made on top of the locomotive hood at two locations approximately 1 ft from the center of the dust bin blower. The locomotive was in the fully quieted condition; i.e., all sources were treated or shut down. With the blower operating, nearfield noise was considerably greater than with the blower shut down (>10 dBA increase). The measurements at the two locations (to the right

and forward of the outlet) were averaged, and transfer functions were used to estimate the levels at the farfield locations.

The *intake source spectra* were obtained by extrapolating air compartment noise levels (with the traction motor blower inlet sealed) to the farfield by use of transfer functions. In a sense, these are an upper bound on the intake noise since these spectra may also contain residual traction motor blower contributions, generator blower, and dc auxiliary generator contributions, etc.

The *dynamic brake fan source spectra* were obtained by running the locomotive self loaded in the full quieted condition (i.e., the condition for the quieted baseline tests). In the self loaded state all the power from the main generator is dissipated in the dynamic brake resistor grids rather than an external load cell. The dynamic brake fans are wired in series with these resistor grids and, hence, attain a speed that increases as the power to be dissipated increases. In all cases, the dynamic brake fans are a significant source that would contaminate noise measurements of the locomotive if it were run in self-load. No spectrum is shown for throttle 4 location 6 as there was an apparent gain setting error in those data. It is apparent that the dynamic brake fan source spectra are similar to cooling fan source spectra.

*Structureborne source contributions* from the engine, main alternator compressor, and cooling fans were determined by measuring the vertical vibration at the mounting points of each of these components\* and using the structureborne transfer function

---

\*For the cooling fans, the vibration was measured at two locations on the locomotive hood on the fan centerline, (1) directly between the forward and middle fans, and (2) between the middle and rear fans. This procedure was consistent with the measurement of the structureborne transfer functions, as described in Appendix B.

described in Appendix D to estimate the radiated sound at the locations of interest around the locomotive. Because of background noise problems, transfer functions are available only for microphone locations 3 and 7.\* In addition, vibration levels at the compressor mounting points were essentially unaffected by whether the compressor was pumping or not. For this reason, we could not distinguish compressor-related vibration from that caused by other sources, such as the engine, and so we give no report on compressor structureborne noise.

The structureborne contributions of the fore and aft engine mounts main alternator mounts and cooling fans are shown in Appendix D, Figs. D.3 - D.8. For each engine mount and the main alternator mount, the estimated spectra are for a single mount. Each of these spectra should be raised 3 dB to account for the symmetrically located mount. In general, structureborne noise from the engine mounts dominates that from other structureborne sources; the resulting spectra are comparable to the engine air-borne source spectra.

#### 4.3 Comparison of Stationary and Pass-By Test Results

As described in Sec. 4.1, even at modest speeds wheel/rail noise is an important component of locomotive noise for the lower throttle settings. At throttle 8, however, wheel/rail noise does not begin to be significant until speeds of 55 to 60 mph are attained. This fact is further illustrated in Fig. 4.18 where a coast-by noise spectrum at 38 mph is similar in shape (except below 100 Hz) and only 5 dBA below the spectrum at 39 mph at throttle 4. The overall level at throttle 8 at 36 mph, however, is 10 dBA greater than the coast-by overall level.

---

\*Data for location 6 had sufficient signal-to-noise but were not consistent with other data and hence are not reported here.

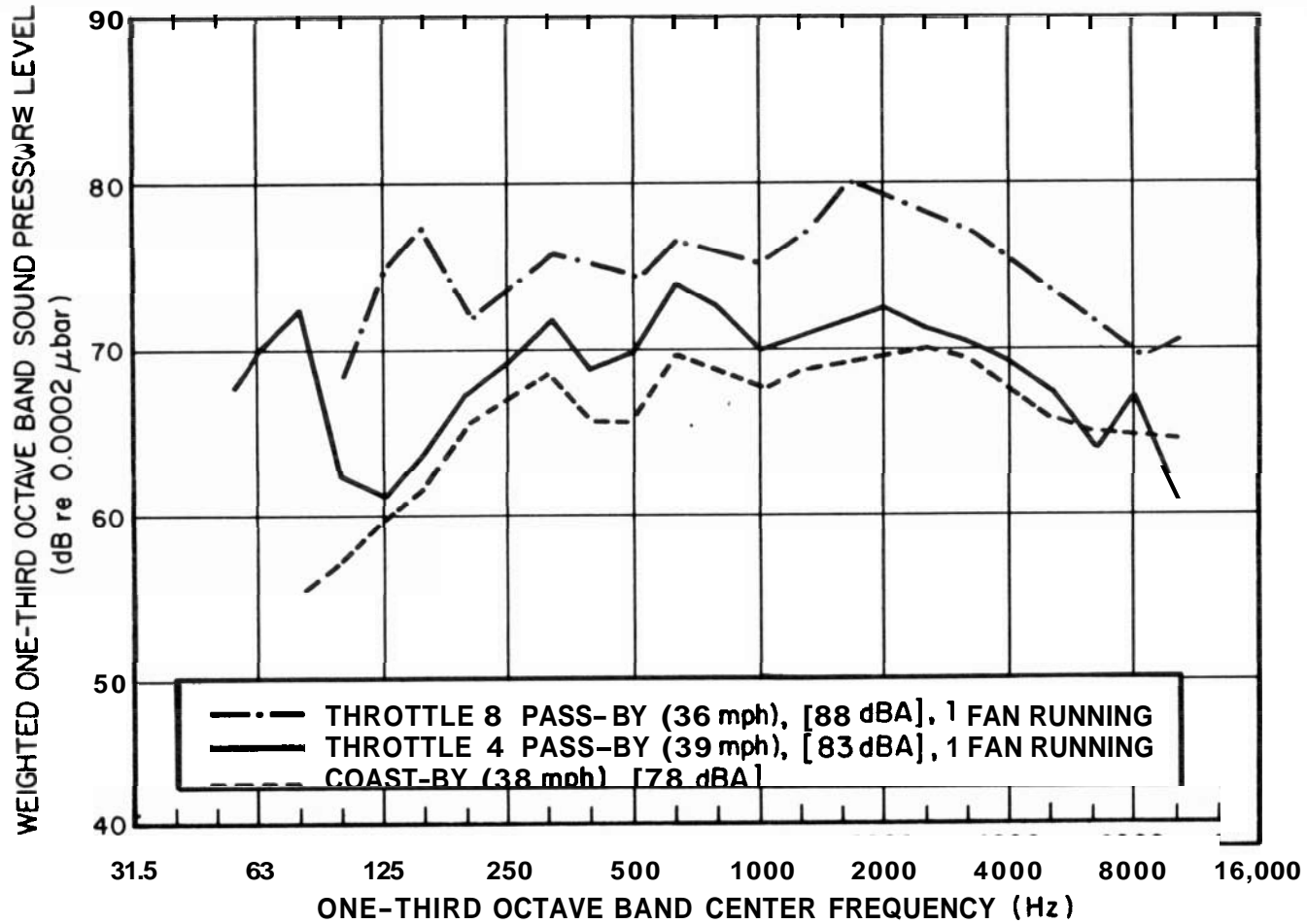

FIG. 4.18. COMPARISON OF POWERED AND UNPOWERED PASS-BYS AT 50 FT AND COOLING FAN OPERATING.

Thus, it is apparent that locomotive noise measured during a pass-by at modest speed at the lower throttle settings is greater than that noise measured with the locomotive stationary and loaded at the same throttle setting. At throttle 8 at modest speed, however stationary and pass-by noise are comparable. Figures 4.19, 4.20, and 4.21 compare spectra taken from 1-sec samples of pass-by data near the peak in the A-weighted sound pressure level with data taken with the locomotive stationary at throttle 8, both loaded and unloaded. In general, the agreement between fully loaded stationary and pass-by spectra is as good as between any two stationary spectra taken at the same location and under the same operating condition. The noise spectra (at the 50 and 100 ft positions) taken with the locomotive stationary and unloaded are generally lower than the spectra for the loaded case and agrees less well with the pass-by noise spectra. At the 25 ft position the noise spectra for the loaded and unloaded cases are remarkably similar above 500 Hz. This occurs probably because fan noise dominates at these higher frequencies and fan noise is not affected by load. It should be noted that the crosshatched region in Fig. 4.21 shows the range of spectra obtained by taking 1-sec segments of data at various times while the A-weighted sound pressure level was peaking. A similar spread in the spectra was not obtained at the closer locations, probably most likely because the duration of the peak A-weighted sound level was shorter for the closer locations\* (see Fig. 4.2, Sec. 4.1).

---

\*1.6 sec between the 3 dB down points at 25 ft, 2 sec at 50 ft, and 6 sec at 100 ft.

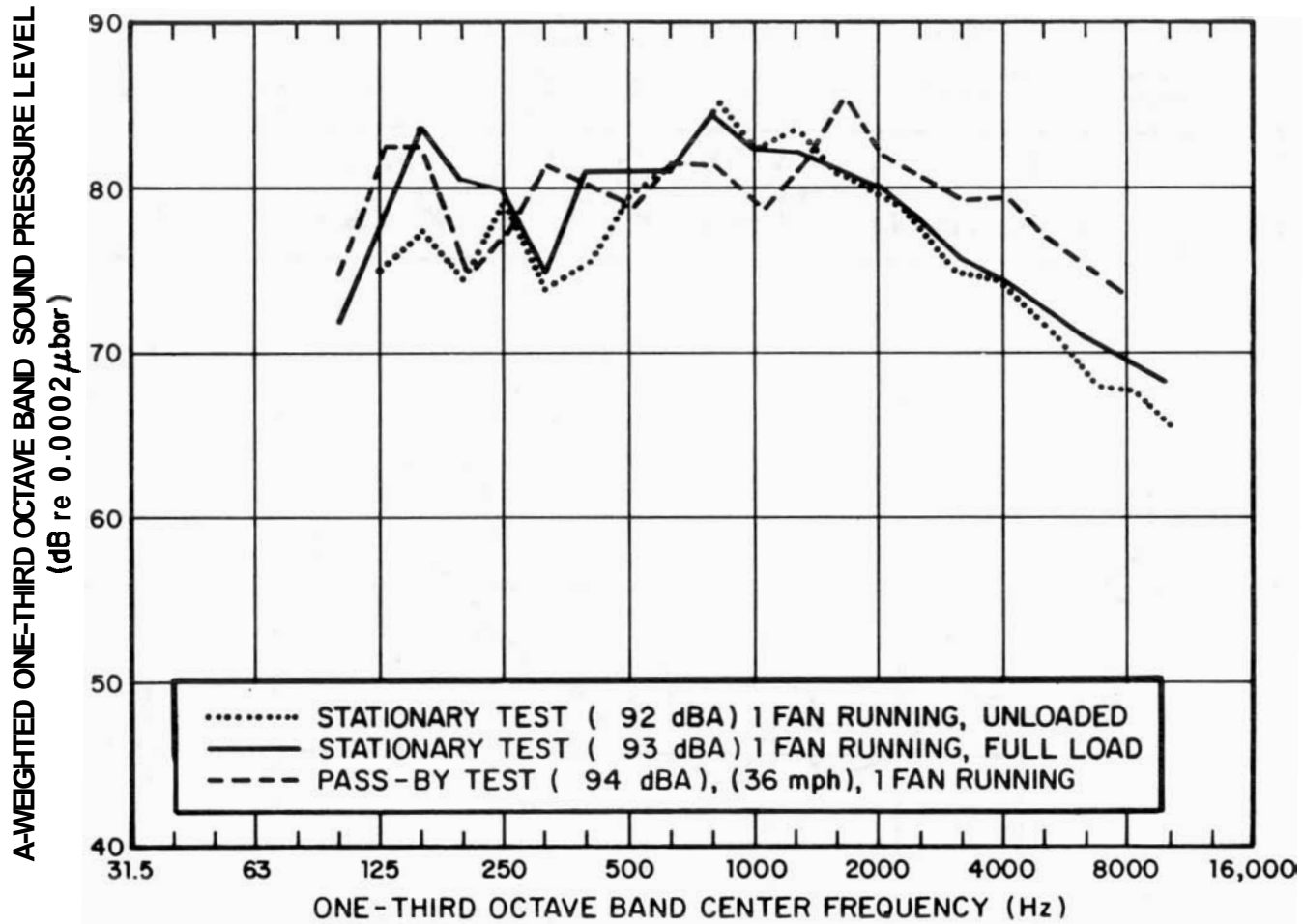

FIG. 4.19. COMPARISON OF STATIONARY AND PASS-BY TESTS AT THROTTLE 8, 25 FT, 36 MPH.



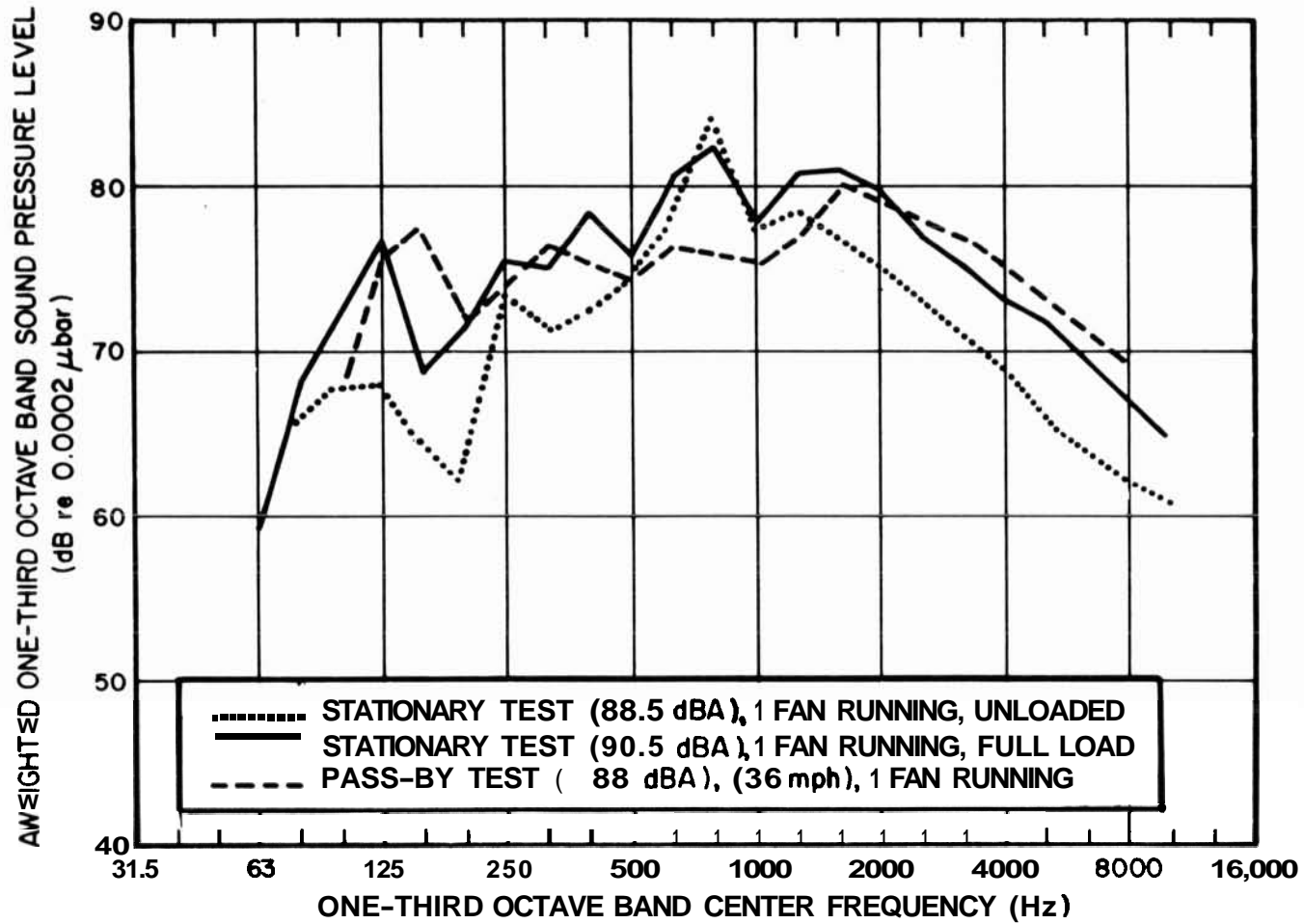

FIG. 4.20. COMPARISON OF STATIONARY AND PASS-BY TESTS AT THROTTLE 8, 50 FT, 36 MPH.

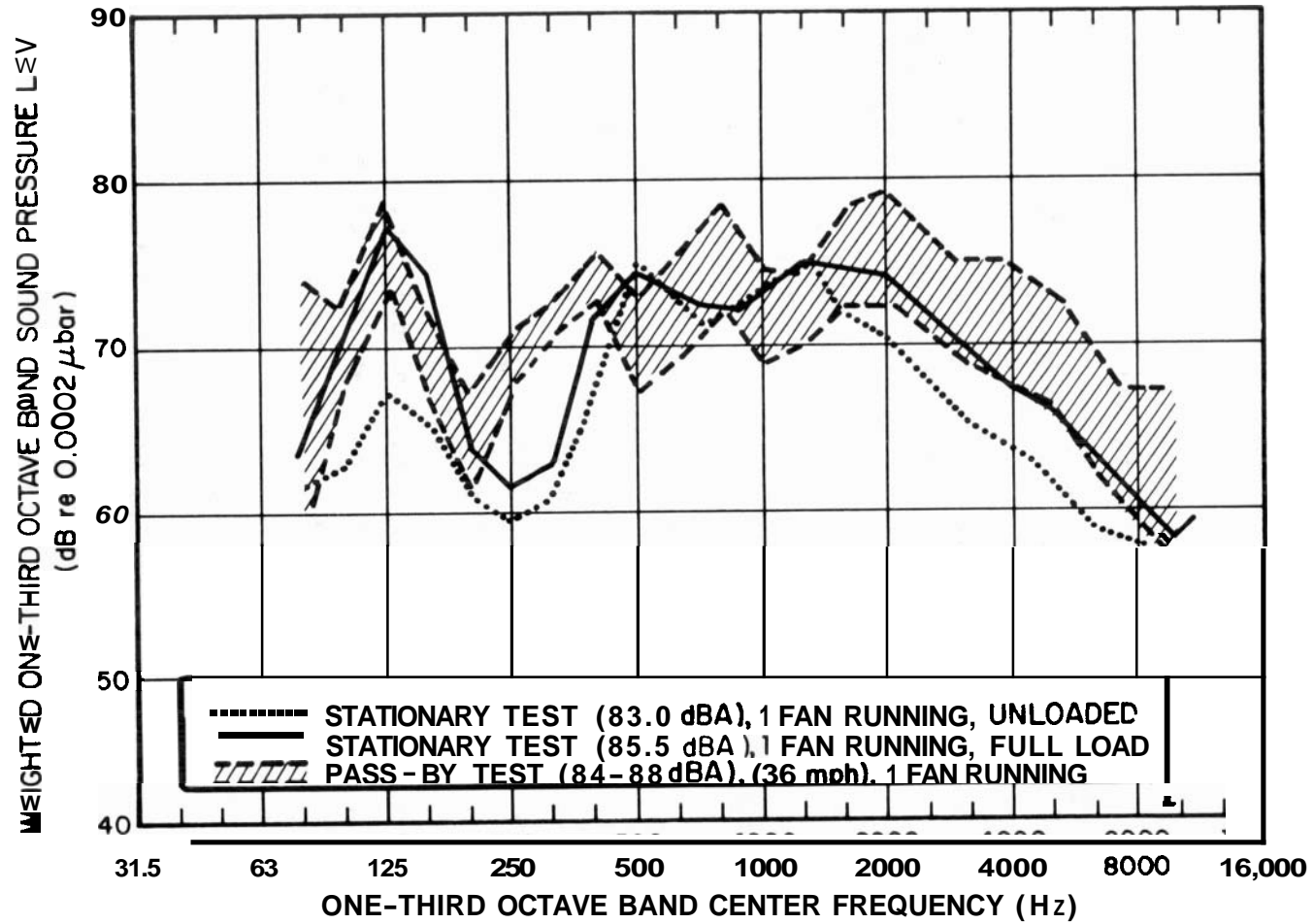

FIG. 4.21. COMPARISON OF STATIONARY AND PASS-BY TESTS AT THROTTLE 8, 100 FT, 36 MPH.

## 5. CONCLUSIONS AND RECOMMENDATIONS

### 5.1 Test Results

#### 5.1.1 Pass-by tests

At the lower throttle settings and at modest speeds, wheel/rail noise is a significant contributor to the noise generated by a passing locomotive. At throttle 8, wheel/rail noise is not significant until speeds of 55 to 60 mph are attained. As a result, one would not expect locomotive noise measured in a stationary test to be comparable to the noise generated during a pass-by test at modest speed at the lower throttle settings. At throttle 8, a stationary (loaded) noise test should adequately simulate the noise generated by a moving locomotive at throttle 8 except for very high speeds.

#### 5.1.2 "Throttle wipe" tests

The major concern in performing the "throttle wipe" tests was to determine whether significantly more noise would be generated during rapid throttle changes than during steady operation at a fixed throttle setting. When changing from throttle 6 to 8 -2 dBA more noise was generated in the loaded condition than in steady operation at throttle 8. In addition, at one microphone location the noise at throttle 5 was found to be -2 dBA higher than the noise at throttle 8. The sources of the latter anomaly is presently uncertain.

#### 5.1.3 Stationary baseline tests

A very important observation made during the stationary baseline tests was the difficulty of obtaining reproducible measurements under apparently acceptable meteorological conditions. Differences in overall level of 2 to 3 dBA were not uncommon even

though spectral averaging times of up to 16 sec were used. We believe that these differences are caused by changes in temperature and wind gradient, which affect the diffraction of sound traveling from the locomotive to the microphone. Oscillations in level can in fact be seen in the "throttle wipe tests" of Sec. 4.2.2. Long-period oscillations, superimposed on higher frequency oscillation probably caused by oscillations in engine speed can be seen at steady operation at all throttle settings. In Fig. 4.36, for example, the long-period oscillations for steady operation at throttle 8 have a peak-to-peak amplitude of approximately 3-4 dBA and a period of approximately 7 sec. However, neither the amplitude nor the period of these long-period variations in level are steady. The result is an inherent uncertainty in the measurements.

Because of this inherent uncertainty in the measurements, it is difficult to make definitive statements concerning even such basic questions as the axial symmetry of the noise from the locomotive. At present, all that can be said with certainty is that the differences in noise from one side of the locomotive to the other are no more than the differences observed in two measurements of the same locomotive at the same microphone location.

#### 5.1.4 Diagnostic tests

The purpose of the diagnostic tests was to determine the magnitude of the contribution of each major source to the noise signature of the locomotive. Although these tests were subject to the same uncertainties as all other tests, it is possible to state that exhaust, cooling fans, engine/alternator, and traction motor blower are the major noise sources in the locomotive. At

---

\*It should be noted in passing that this uncertainty appears to be considerably less for those microphones located 10 ft above the ground, locations 8 and 9.

idle, exhaust and engine/alternator are the major sources. At throttle 4, exhaust and cooling fans are the dominant source, although for the more distant locations cooling fans may fall as much as 10 dBA below exhaust. At throttle 8 both exhaust and cooling fans are the dominant sources for all locations around the locomotive. The traction motor blower falls approximately 10 dBA below exhaust for the more distant location; it is a somewhat stronger source for the closeby locations.

The major source of structureborne noise is the engine itself; it produces structureborne sound that is comparable to engine/alternator airborne sound.

## **5.2 Noise Control**

The discussion in Sec. 5.1.4 indicates clearly that any significant reduction in locomotive noise can be achieved only if exhaust, radiator cooling fans, and engine/alternator are all treated. To achieve more extensive quieting (10- to 15-dBA) it would also be necessary to treat the traction motor blower.

### ***Exhaust Noise***

Exhaust noise is best treated with an exhaust muffler. The major difficulty with this treatment is the limited size of the space under the hood that must accommodate a muffler of sufficient volume to achieve the desired attenuation. Exterior mounting of mufflers on the larger line-haul locomotives is generally not considered feasible because of the limited clearance between the hood and tunnels. Although turbochargers do provide some reduction of exhaust noise turbocharged locomotives present an additional difficulty; severe backpressure limitations, i.e., on the order of 5 in. of H<sub>2</sub>O, severely constraining muffler design. It

has been demonstrated that these difficulties can be overcome to some degree. Mufflers have been designed and installed on some new locomotives. For example, Universal Silencer, in conjunction with EMD, developed a silencer for AMIRAK locomotives. These locomotives used a 20-cylinder version of the engine in the SD40-2 locomotive.

If an exhaust silencer were designed that reduced exhaust noise 10 dBA, one would achieve the following reductions in overall locomotive noise measured at microphone location 3 (100 ft to the side of the locomotive with 3 cooling fans operating):

	dB	dB
		dBA
a. idle	3	4
b. throttle 4	4	5
c. throttle 8	2	3

#### *Cooling Fan Noise*

Fan noise is usually treated in one of two ways. Obstructions to the flow entering the fan are removed or the pumping efficiency of the fan is improved so that fan speed can be reduced. The first approach reduces turbulence entering the fan, and, hence, the resulting noise due to the fluctuating pressures on the fan blades as they encounter the turbulent eddies. The second approach allows the fan speed to be reduced so as to take advantage of the dependence of fan noise on the fan velocity to the sixth power.

In the first approach, any structure in the fan inlet is minimized or moved as far in front of the fan blades as possible. On the SD40-2, there are a number of struts supporting the fan drive motors just in front of the fan blades. Moving these struts farther away from the fan blades would reduce any tones at the blade passage frequency or multiples of that frequency.

To improve the fan pumping efficiency, one can increase the fan size, reduce clearances between the fan and its shroud, or - in some cases - redesign the fan blades. Locomotive space restrictions probably prevent any significant increase in fan diameter. Reduced clearance between the fan blades and the shroud may be possible but present clearances are not excessive and little gain is anticipated. Redesign of the fan blade may result in some improvement although existing locomotive fan blades are already fairly sophisticated and improvements in this area may be minimal. A final possibility, although less attractive because of the major redesign involved, is a redesign of the cooling system so that lower air flow rates and, hence, fan speeds, can be tolerated.

If fan noise and exhaust noise were each reduced by 10 dBA,\* the resulting reduction in overall locomotive noise at microphone location 3 (100 ft to the side of the locomotive) would be

	dB A
a. idle	3 - 4
b. throttle 4	6 - 7
c. throttle 8	6 - 7

#### *Engine/Alternator Noise*

Reduction of engine/alternator noise is especially difficult as present estimates place the structureborne contribution from the engine at very nearly the same levels as the airborne contribution. This finding implies the need for vibration isolation, which would cause extreme alignment problems with present EMD

---

\*For fans this would imply that a 30% reduction in speed would be possible or, in other words, that throttle 4 fan speed would be sufficient for cooling at throttle 8. There is no information available at this time to indicate that such a speed reduction is achievable within reasonable operational and cost constraints.

designs where the engine and alternator are mounted separately. Some reduction in locomotive noise has been demonstrated during this program by the simple application of absorptive treatments inside the hood and by sealing of the hood doors and latches. In a practical application, the absorptive treatment must be made impervious to oil and diesel fuel and protected against mechanical damage as has been done successfully in the DOT Quiet Truck (described in Report No. DOT-TST-74-20"). Similar techniques could be applied here.

During this program, treatment reduced engine/alternator noise 3 dBA at idle, 4 dBA at throttle 4, and 1.5 dBA at throttle 8. If this treatment were combined with a 10-dBA reduction in exhaust and fan noise, the following overall reduction in locomotive noise would result:

	dB
a. idle	6 - 7
b. throttle 4	7 - 8
c. throttle 8	7 - 8

Some small additional reductions in noise might be accomplished at the higher throttle settings by treating the traction motor blower.

### 5.3 Future Work

The data presented in this report represents only part of all the data acquired during the field testing. As a result, additional work will be analyzed and documented in a future report dealing primarily with the relationship between moving and

---

\*E.K. Bender, W.N. Patterson, and M.C. Kaye (1974). "Truck Noise IIIC: Source Analysis and Experiments with Noise Control Treatments Applied to Freightliner Quiet Truck," Department of Transportation Report No. DOT-TST-74-20.



stationary test results. In addition to the above we recommend future work in three areas:

- a. Additional diagnostic work
- b. Work to develop reproducible measurement techniques
- c. A quiet locomotive demonstration project.

The work reported here is really applicable only to one class of locomotives, i.e., the turbocharged locomotives produced by EMD. The other major domestic manufacturer, General Electric, produces locomotives that are in many ways different from EMD locomotives. For example, the engines are 4-stroke rather than 2-stroke diesels, and the cooling fan is mechanically rather than electrically driven. Both these differences, regardless of others, could result in considerable differences in noise. A noise measurement program on a GE locomotive, similar to the one carried out here, would be in order.

One of the major difficulties encountered in this program was the lack of reproducibility in the measurements. We felt that this problem was caused by wind and temperature gradients, **which** changed the diffraction of sound from the locomotive to the microphone. It is imperative for the acquisition of accurate measurement techniques for reproducible noise measurement be determined. One approach might be to measure the noise simultaneously at several heights at each location of interest around the locomotive. By averaging the measurements from all heights at a **given** location, noise variation due to diffraction changes might be averaged out. This technique and others like it should be examined.

Much of the information generated during this program **is** fundamental to a noise reduction program. An **industry/government**

demonstration project similar to the DOT Quiet Truck Program, with the objective of quieting a locomotive, would be a natural out-growth of the program discussed in this report.



APPENDIX A  
BASELINE NOISE SPECTRA

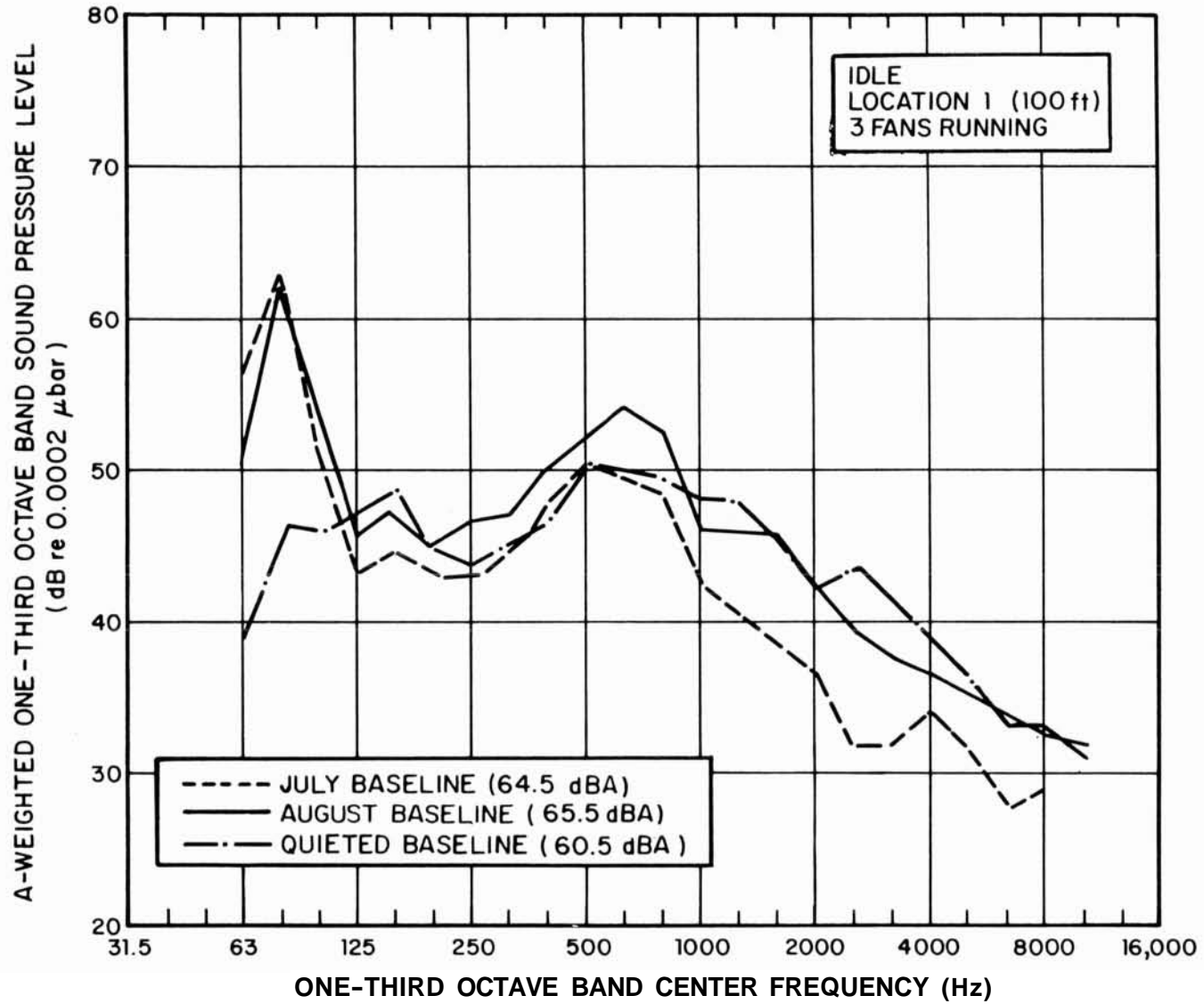

FIG. A.1. LOCOMOTIVE BASELINE NOISE, IDLE, MICROPHONE LOCATION 1.

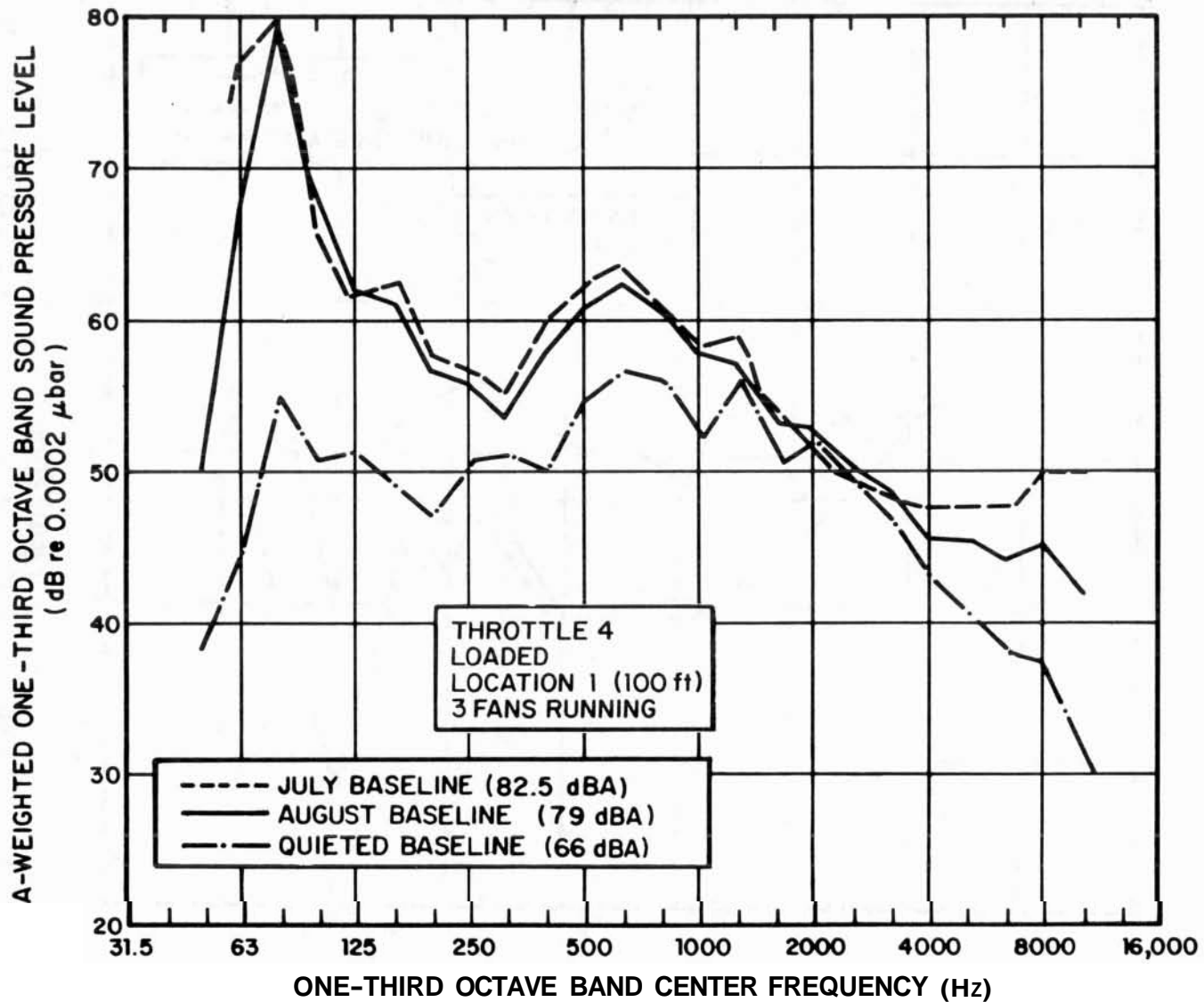

FIG. A.2. LOCOMOTIVE BASELINE NOISE, THROTTLE 4, FULL LOAD, MICROPHONE LOCATION 1.

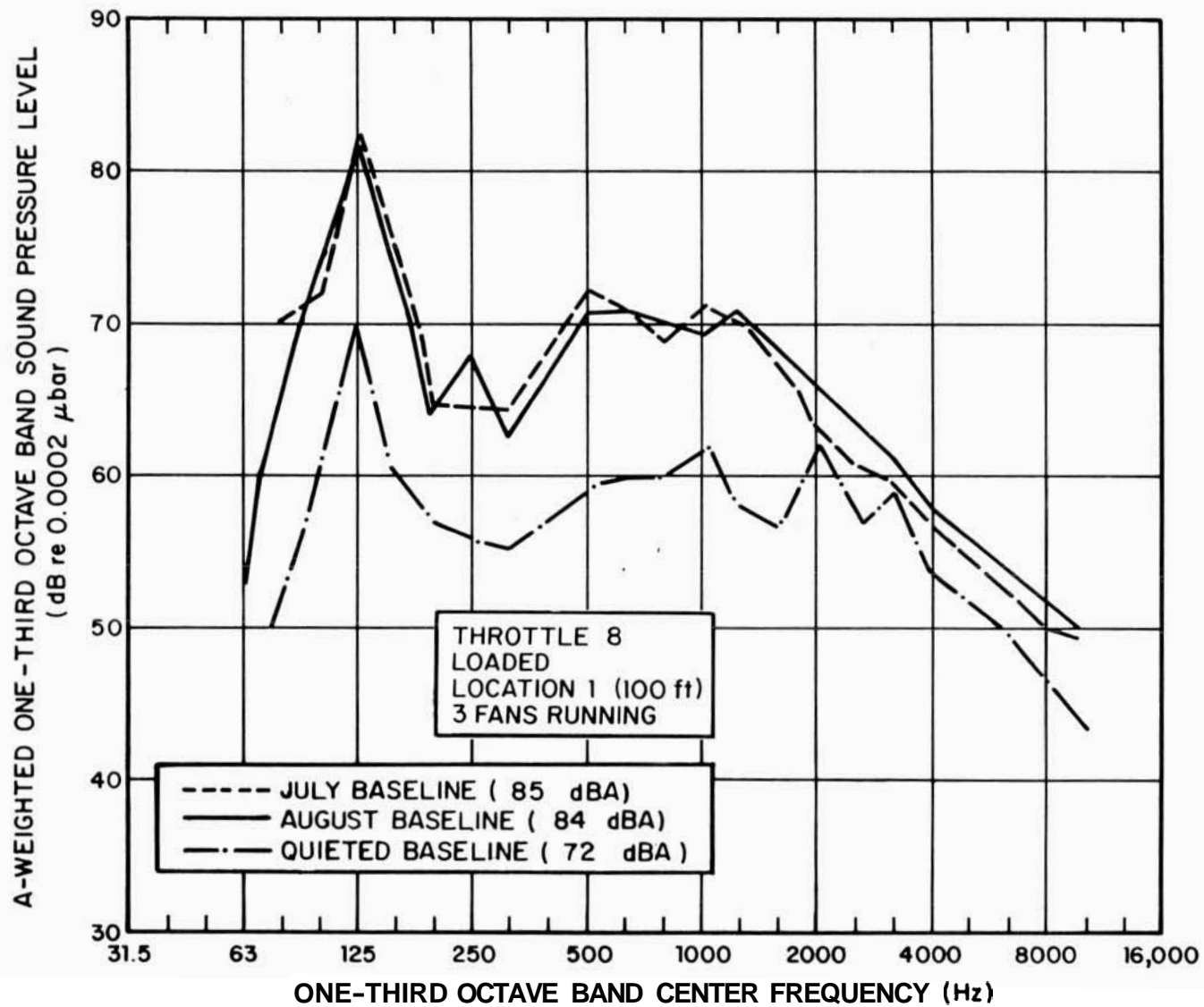

FIG. A.3. LOCOMOTIVE BASELINE NOISE, THROTTLE 8, FULL LOAD, MICROPHONE LOCATION 1.

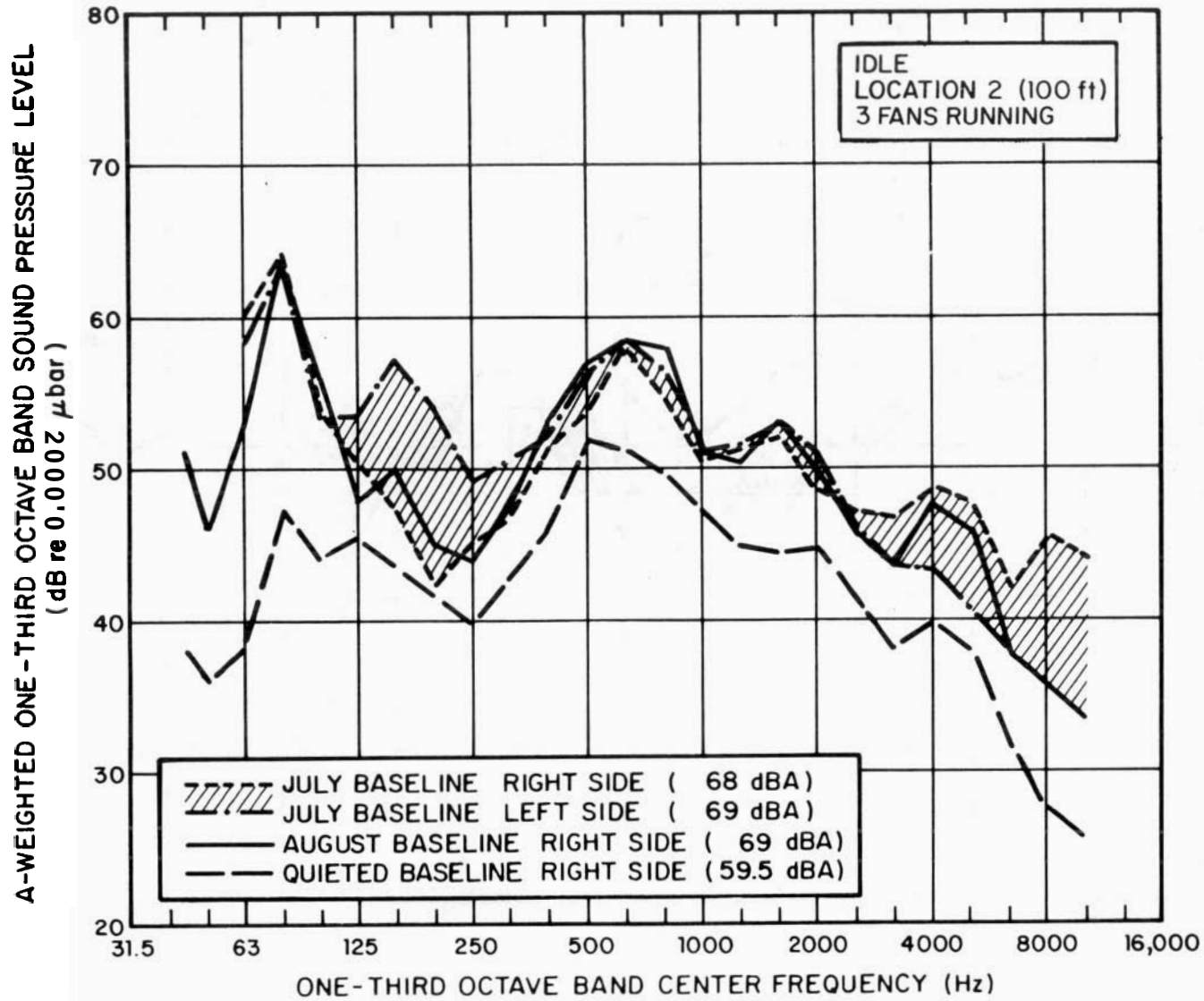

FIG. A.4. LOCOMOTIVE BASELINE NOISE, IDLE, MICROPHONE LOCATION 2.



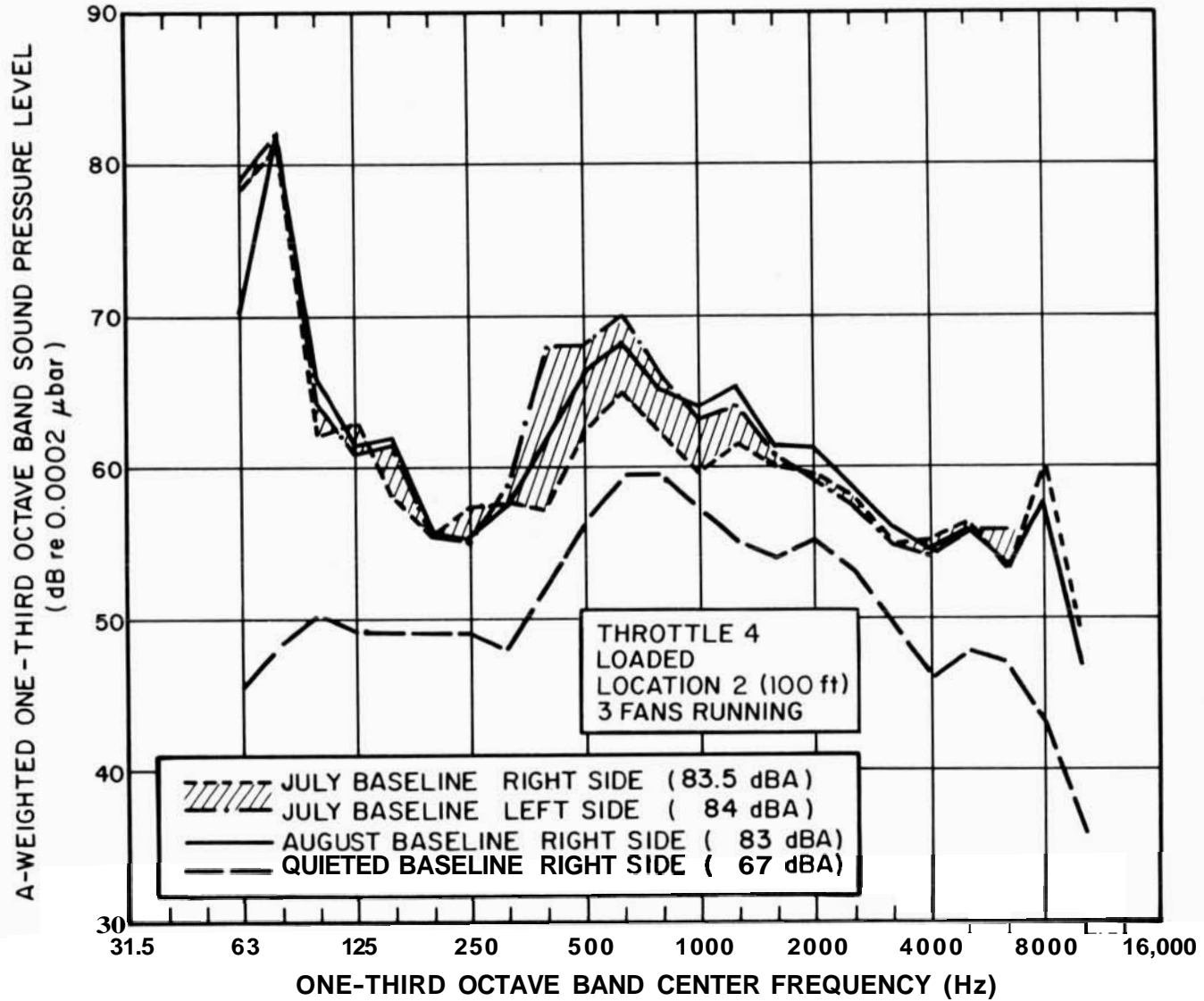

FIG. A.5. LOCOMOTIVE BASELINE NOISE, THROTTLE 4, FULL LOAD, MICROPHONE LOCATION 2.

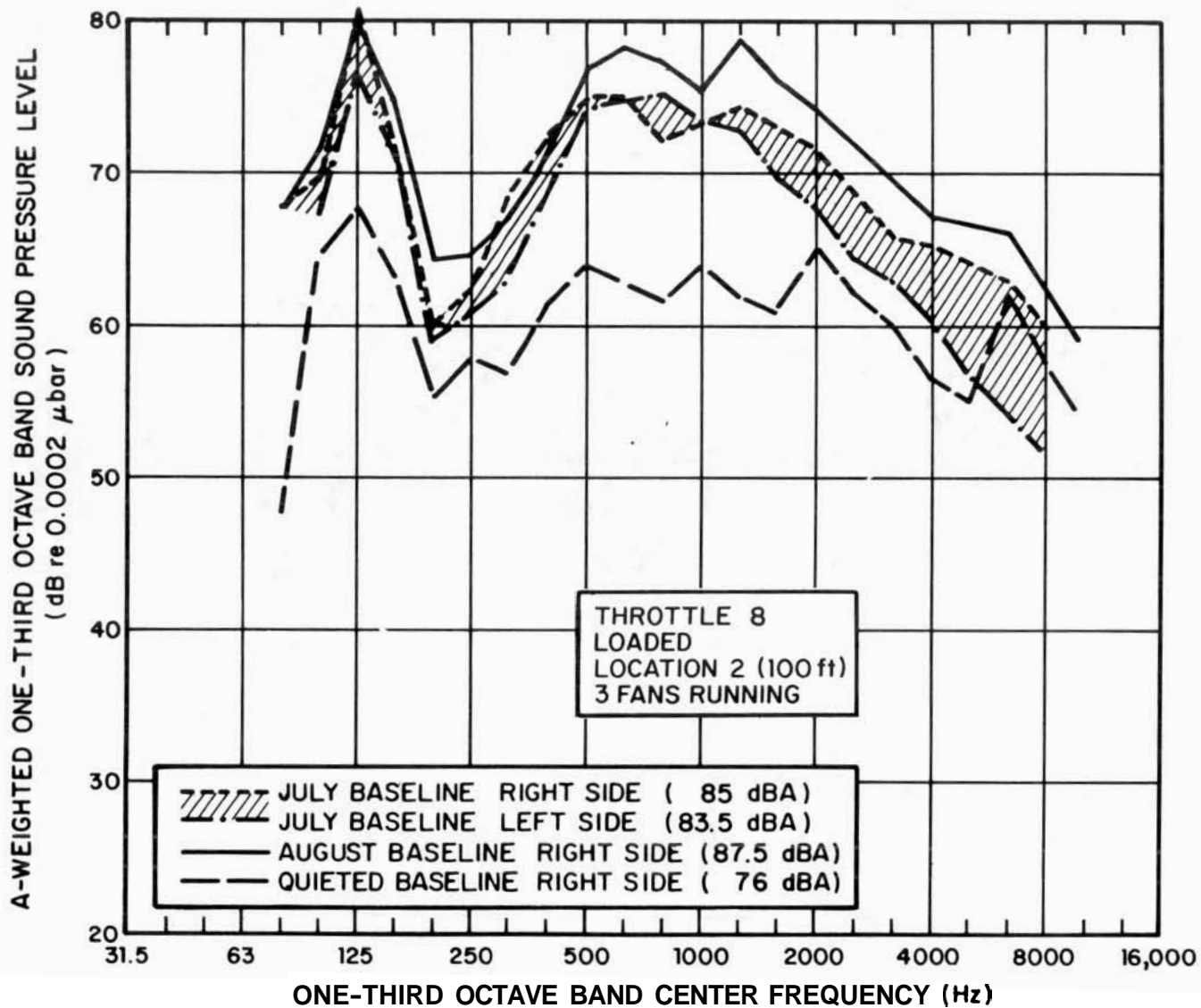

FIG. A.6. LOCOMOTIVE BASELINE NOISE, THROTTLE 8, FULL LOAD, MICROPHONE LOCATION 2.

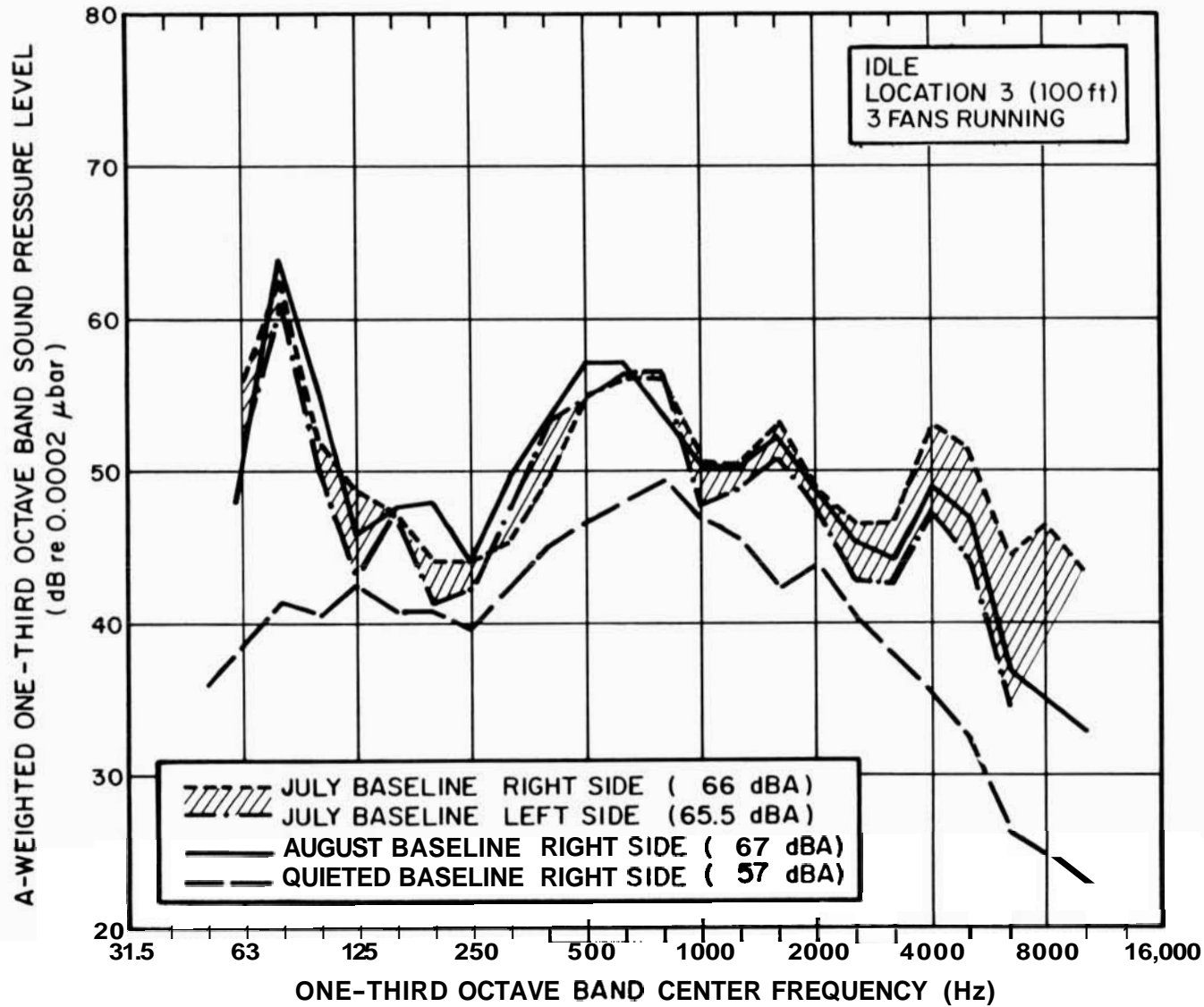

FIG. A.7. LOCOMOTIVE BASELINE NOISE, IDLE, MICROPHONE LOCATION 3.

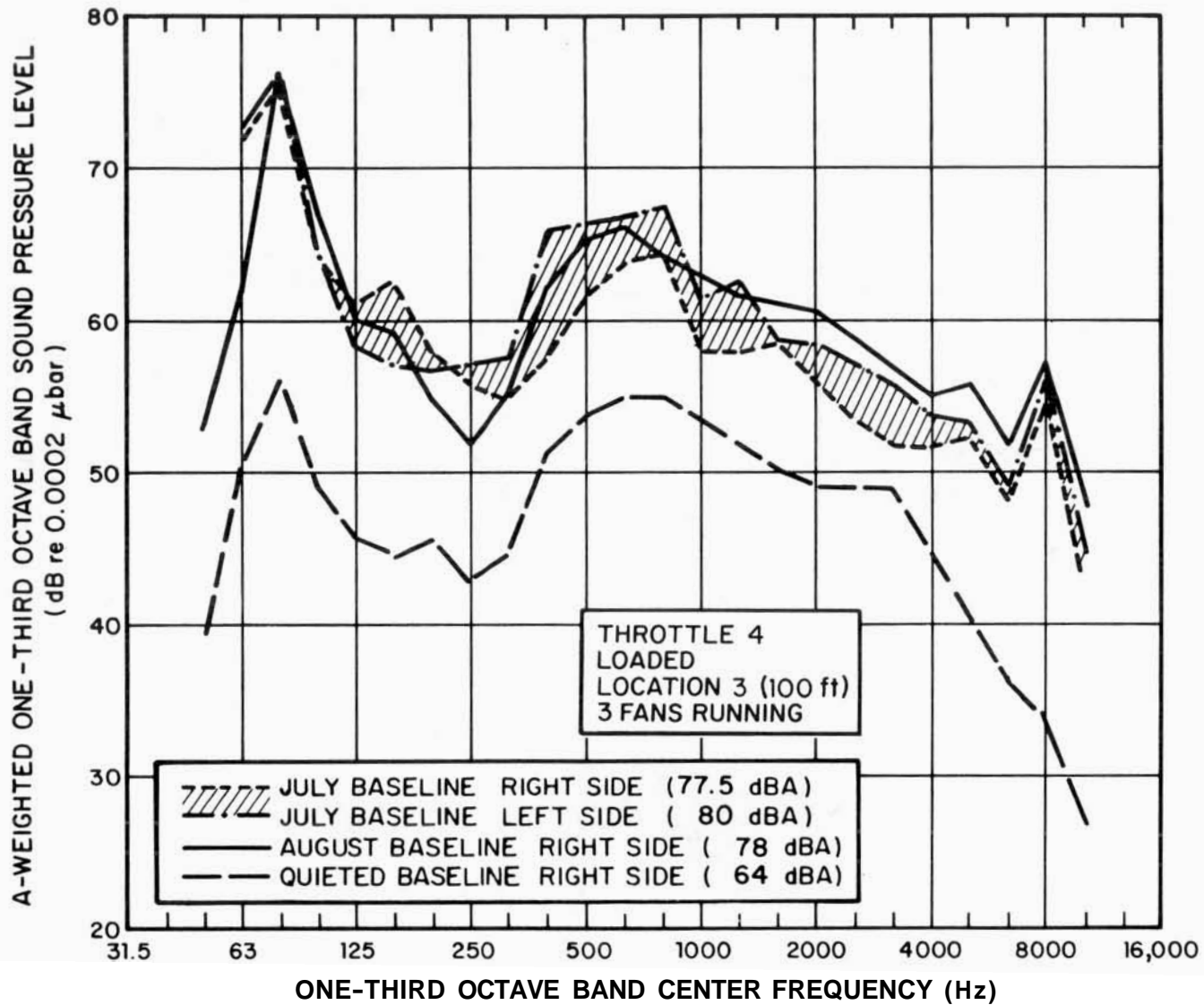

FIG. A.8. LOCOMOTIVE BASELINE NOISE, THROTTLE 4, MICROPHONE LOCATION 3.

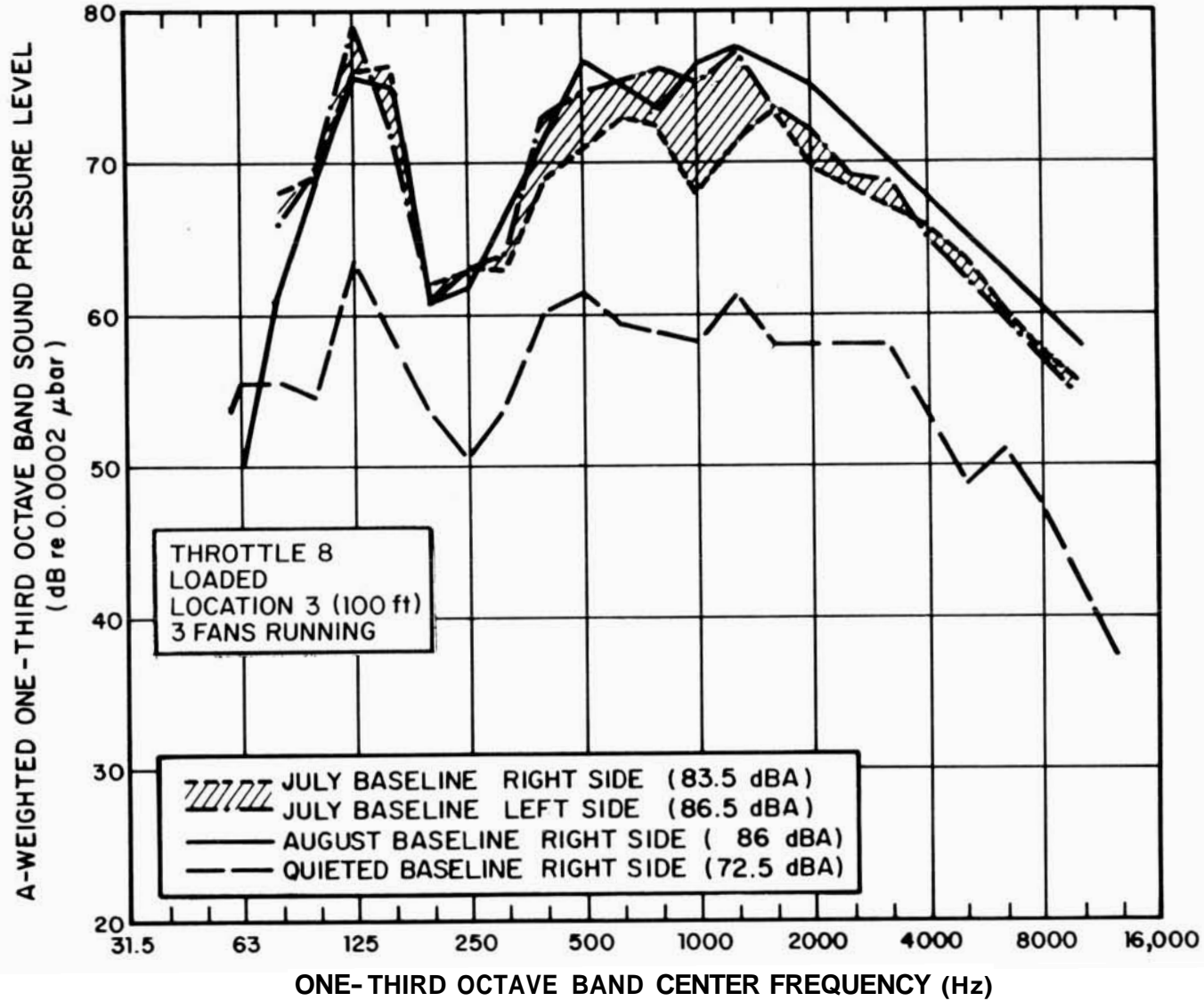

FIG. A.9. LOCOMOTIVE BASELINE NOISE, THROTTLE 8, FULL LOAD, MICROPHONE LOCATION 3.

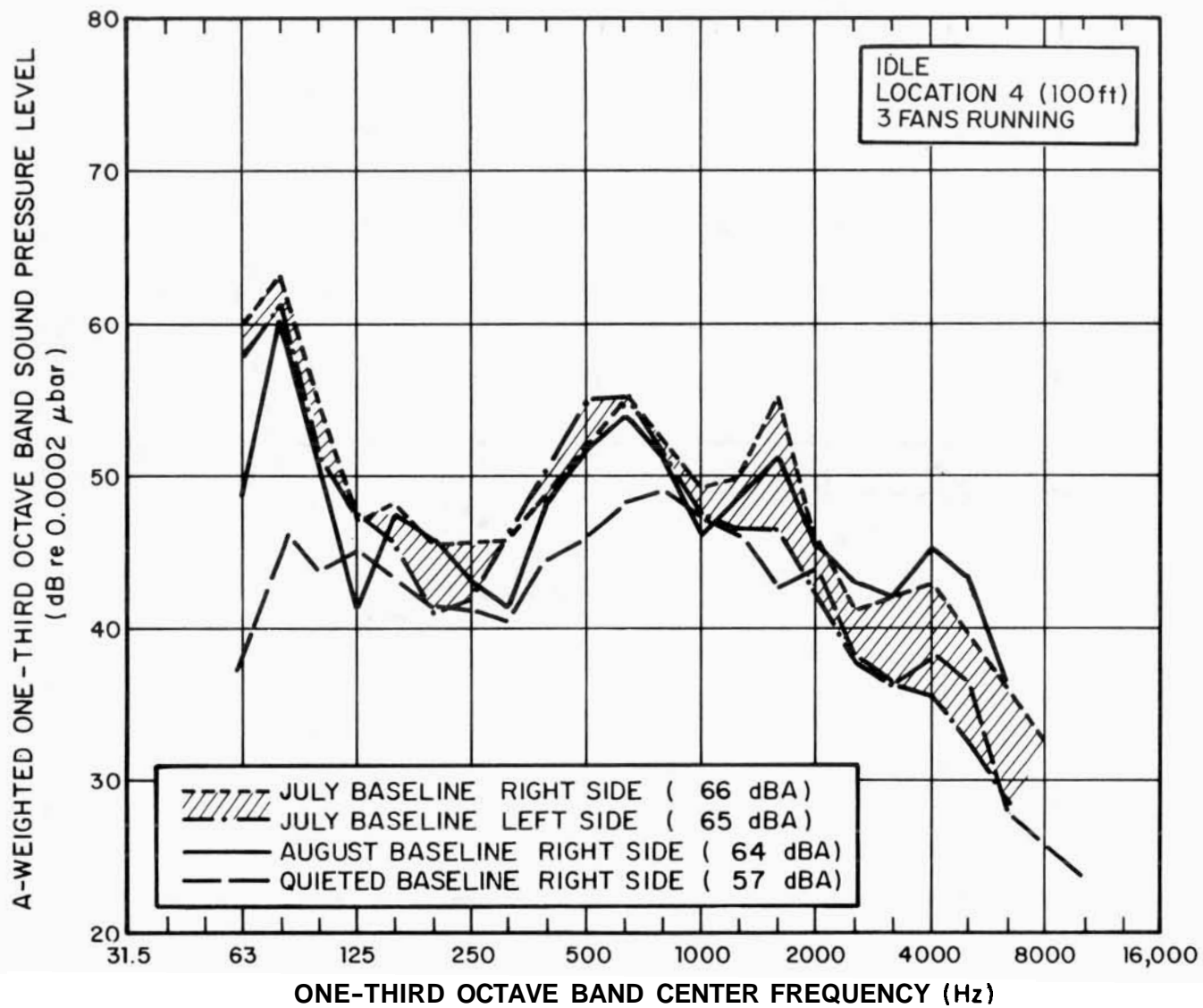

FIG. A.10. LOCOMOTIVE BASELINE NOISE, IDLE, MICROPHONE LOCATION 4.

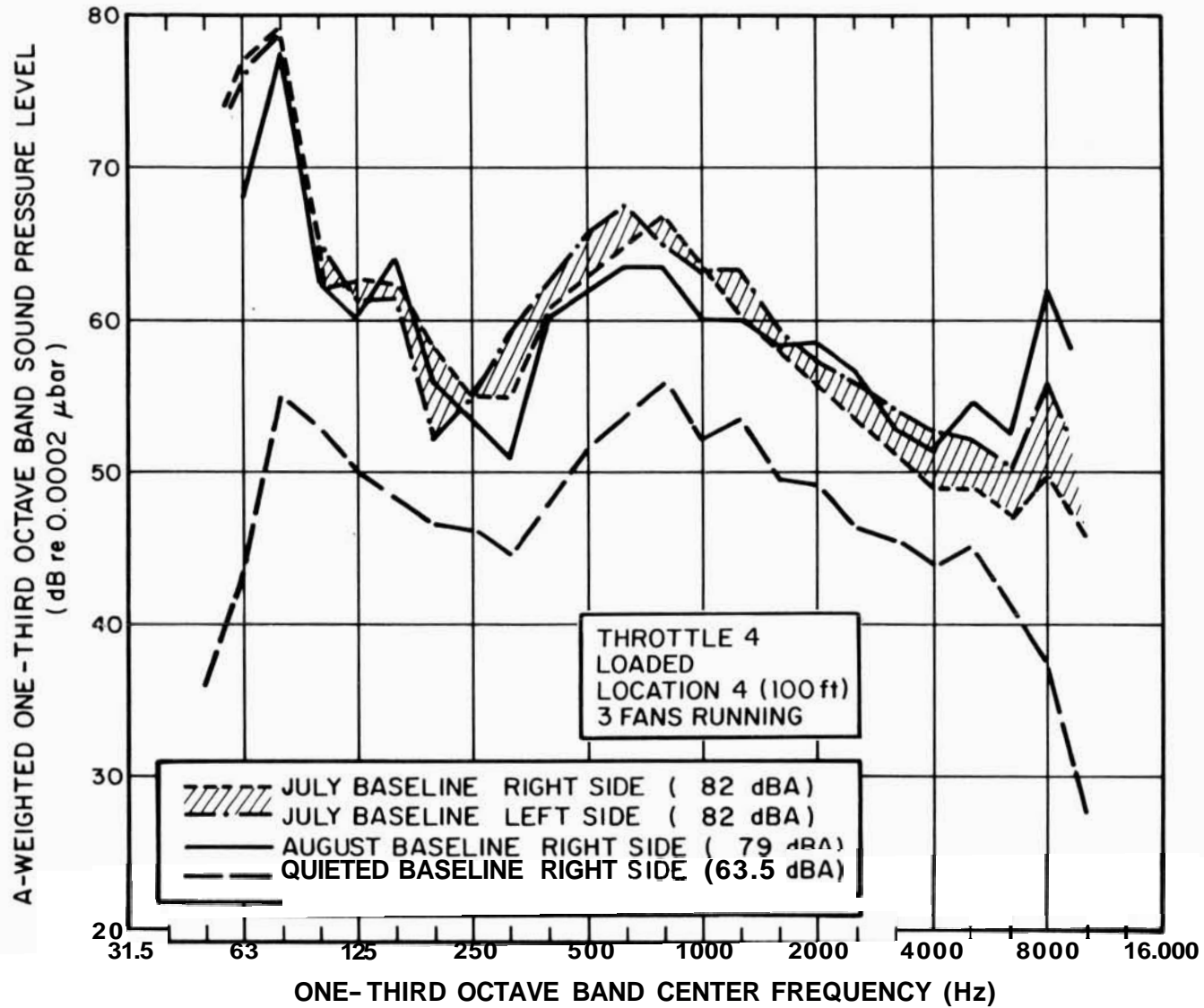

FIG. A.11. LOCOMOTIVE BASELINE NOISE, THROTTLE 4, FULL LOAD, MICROPHONE LOCATION 4.

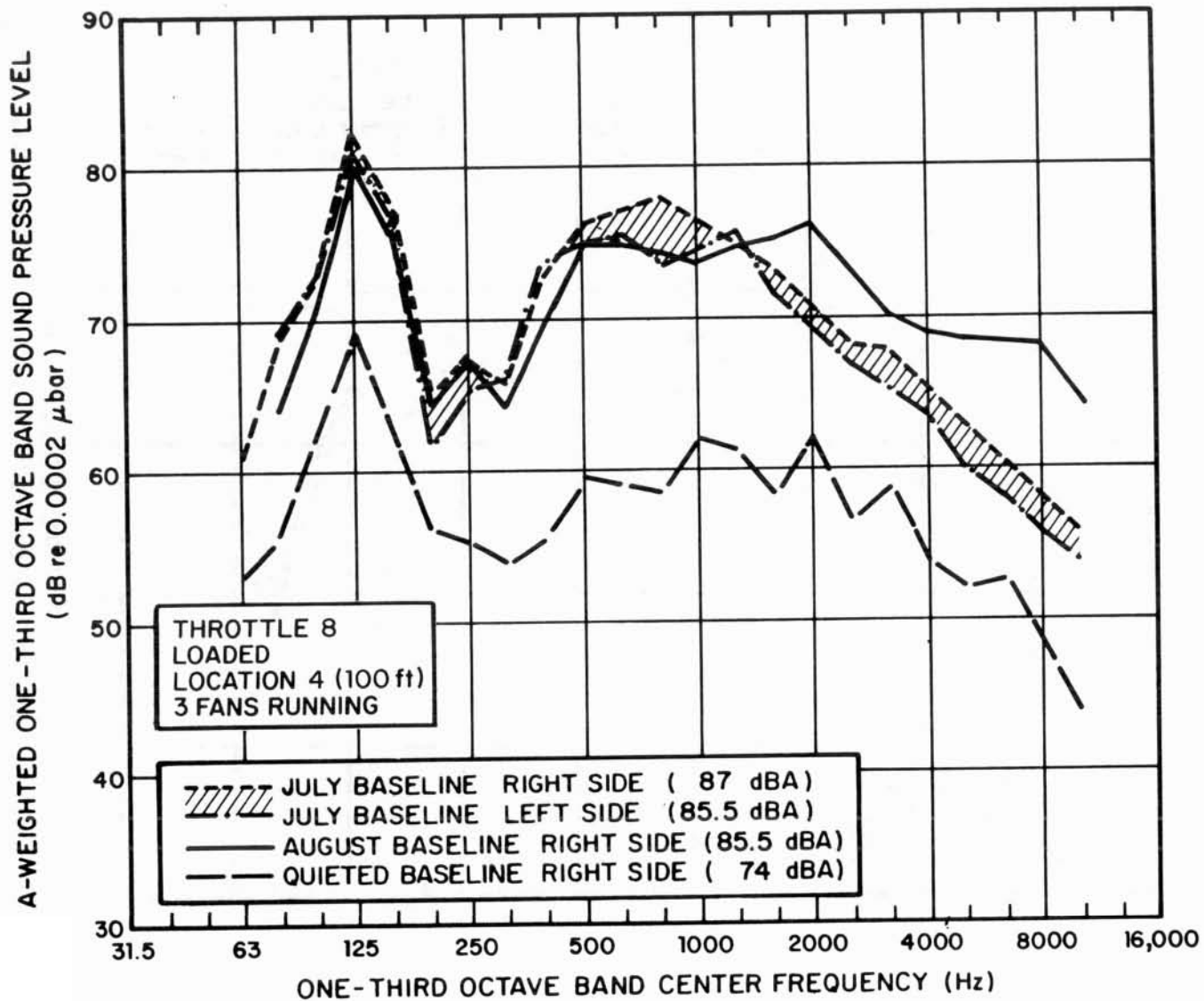

FIG. A.12. LOCOMOTIVE BASELINE NOISE, THROTTLE 8, FULL LOAD, MICROPHONE LOCATION 4.



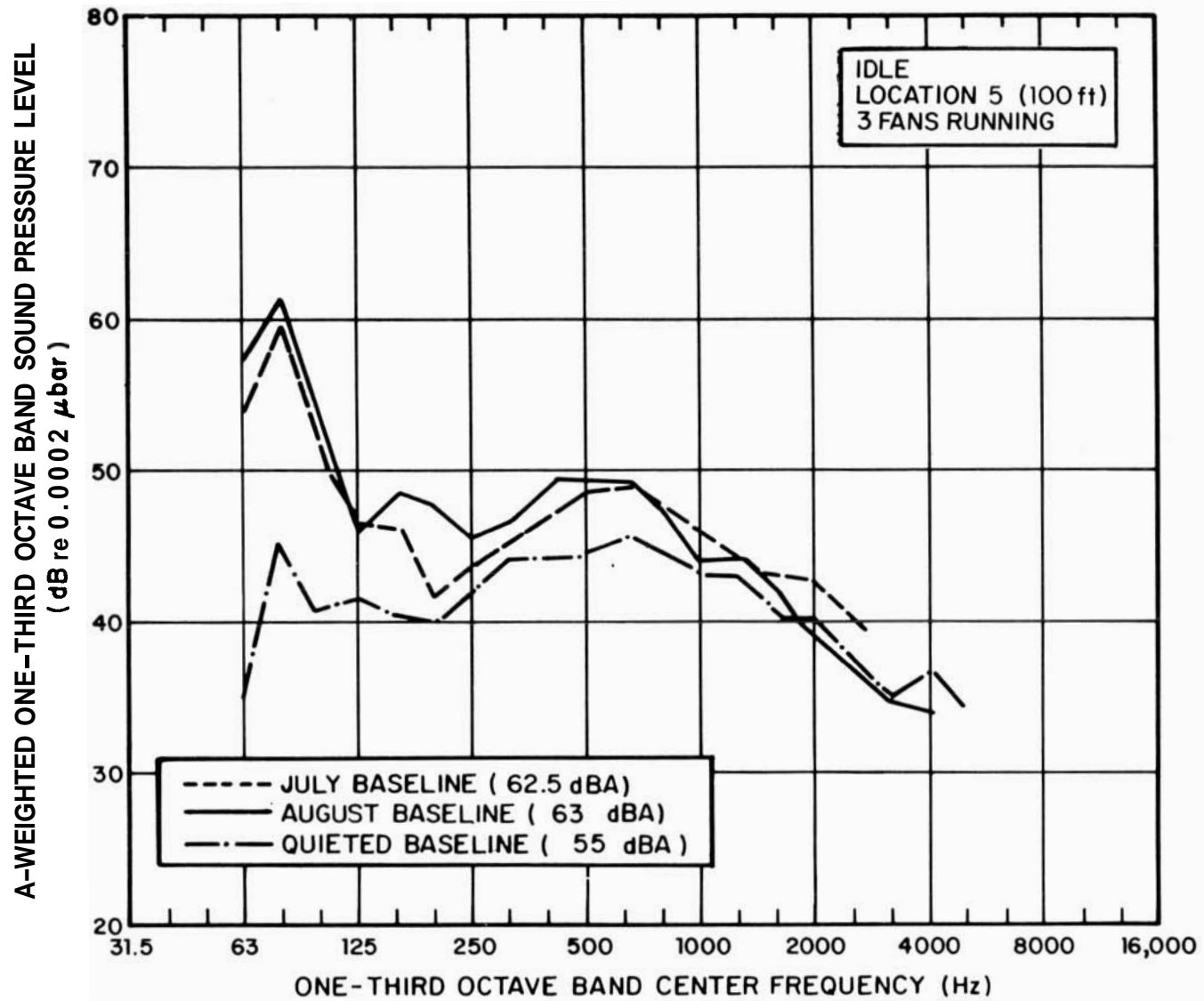

FIG A.13. LOCOMOTIVE BASELINE NOISE, IDLE, MICROPHONE LOCATION 5.

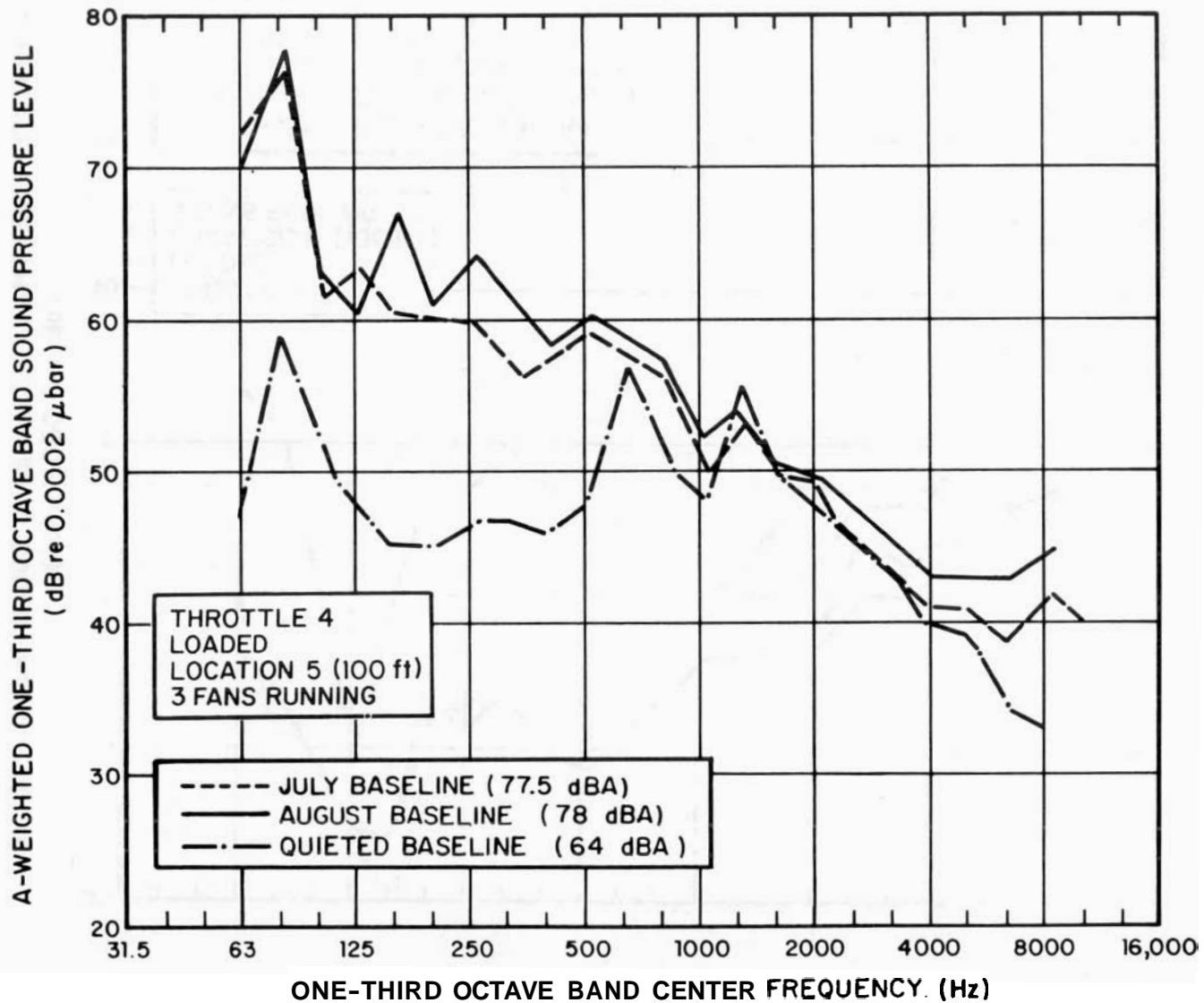

FIG. A.14. LOCOMOTIVE BASELINE NOISE, THROTTLE 4, FULL LOAD, MICROPHONE LOCATION 5.

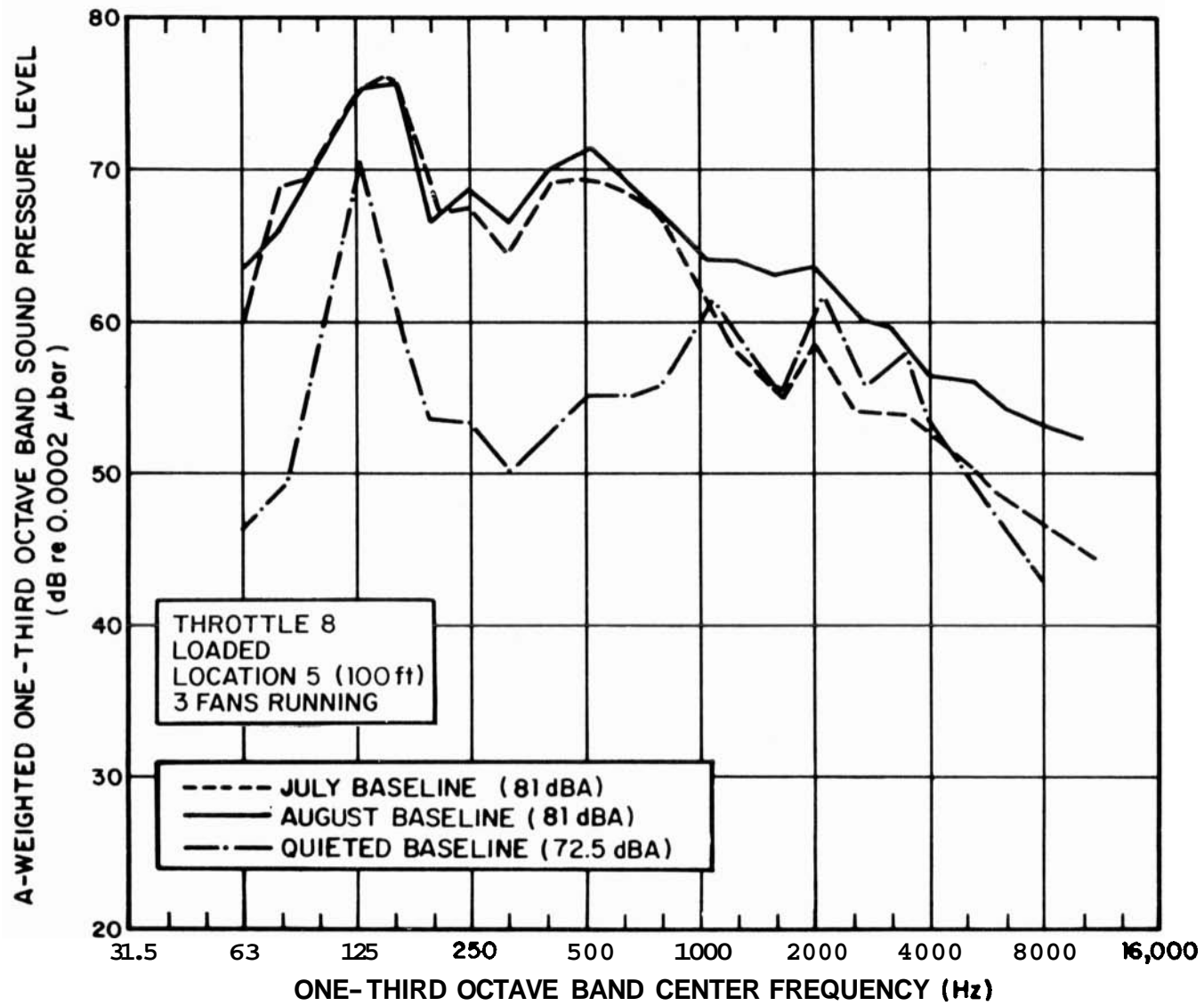

FIG. A. 15. LOCOMOTIVE BASELINE NOISE, THROTTLE 8, FULL LOAD, MICROPHONE LOCATION 5.

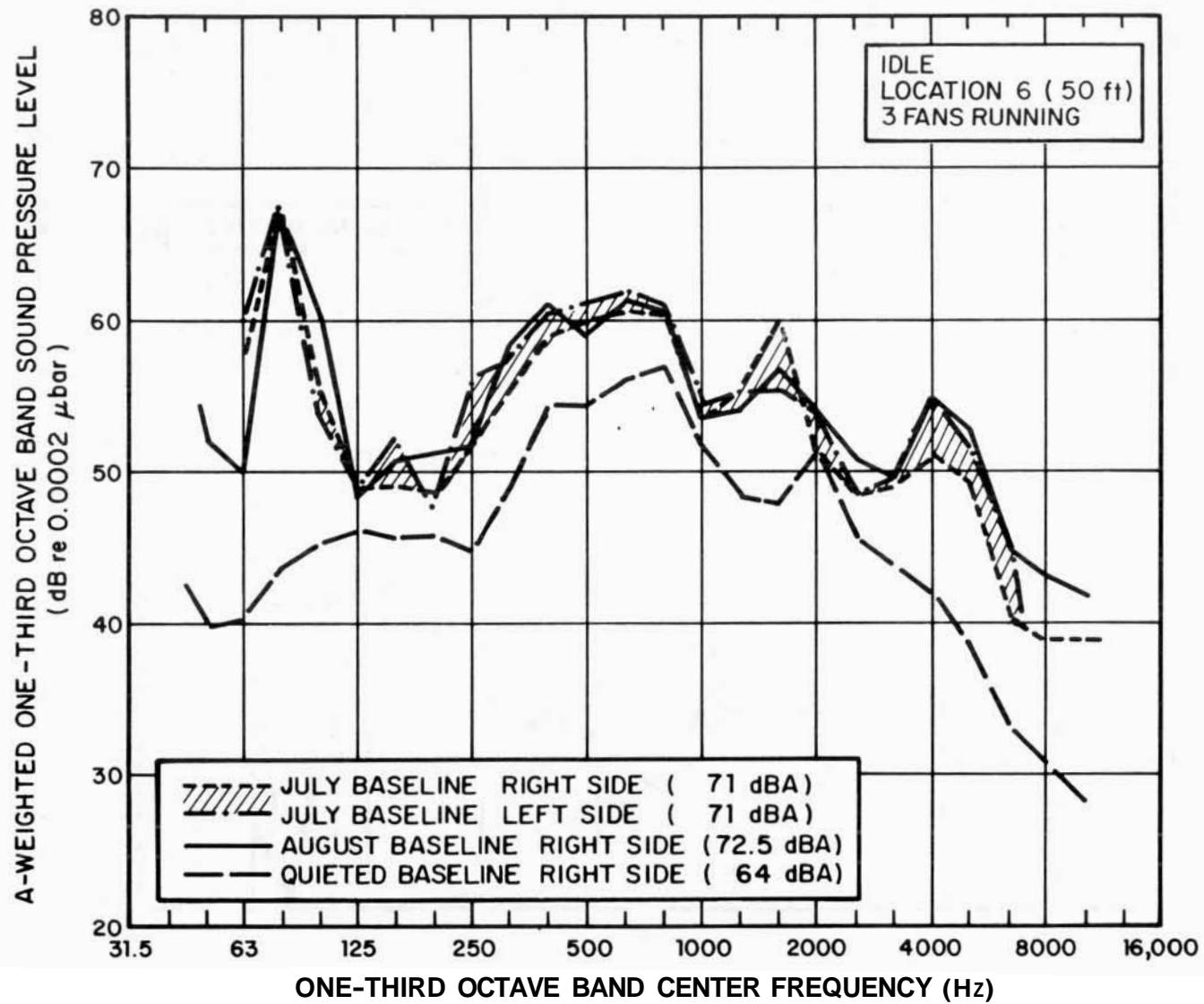

FIG. A.16. LOCOMOTIVE BASELINE NOISE, IDLE, MICROPHONE LOCATION 6.

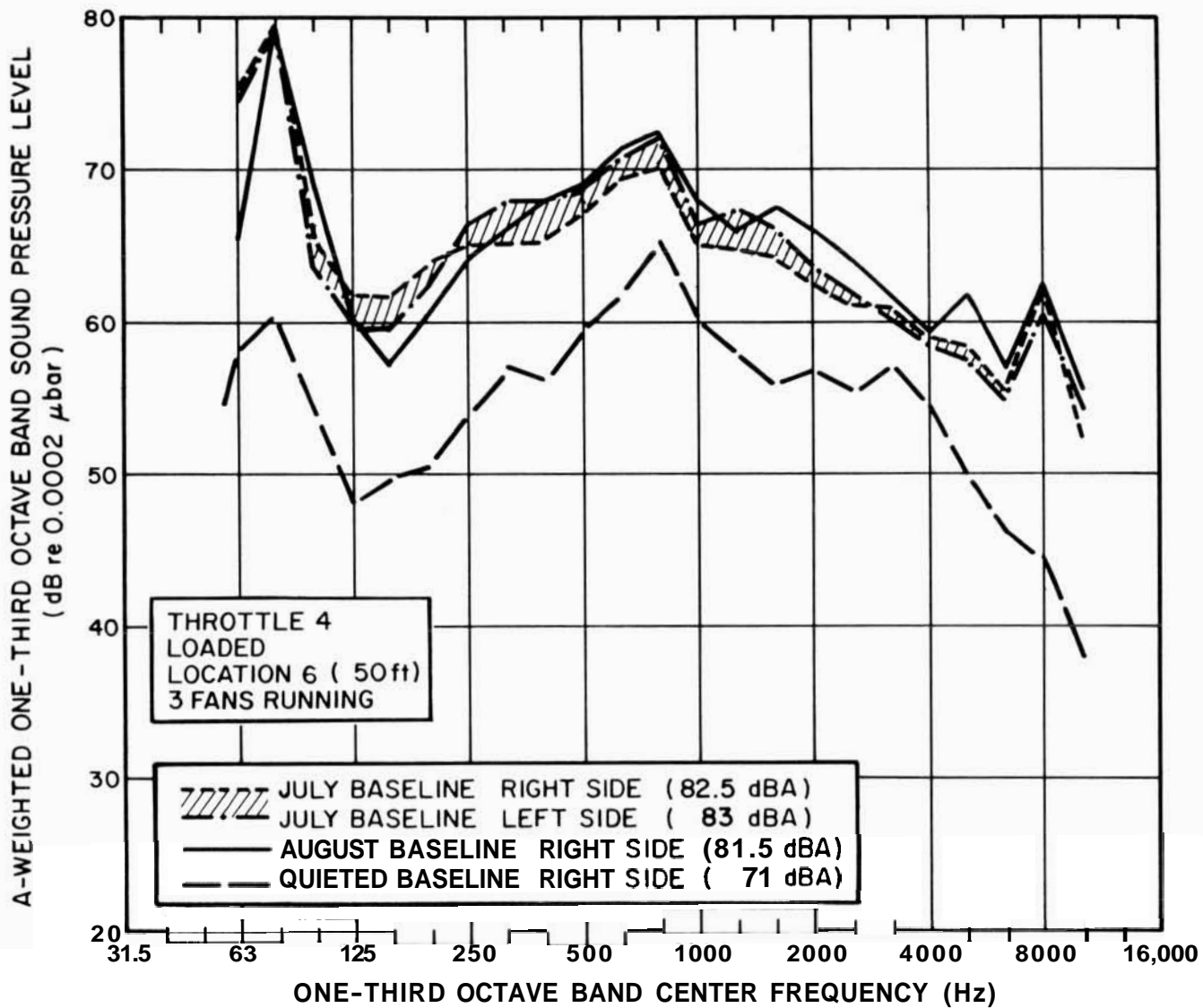

FIG. A.17. LOCOMOTIVE BASELINE NOISE, THROTTLE 4, FULL LOAD, MICROPHONE LOCATION 6.

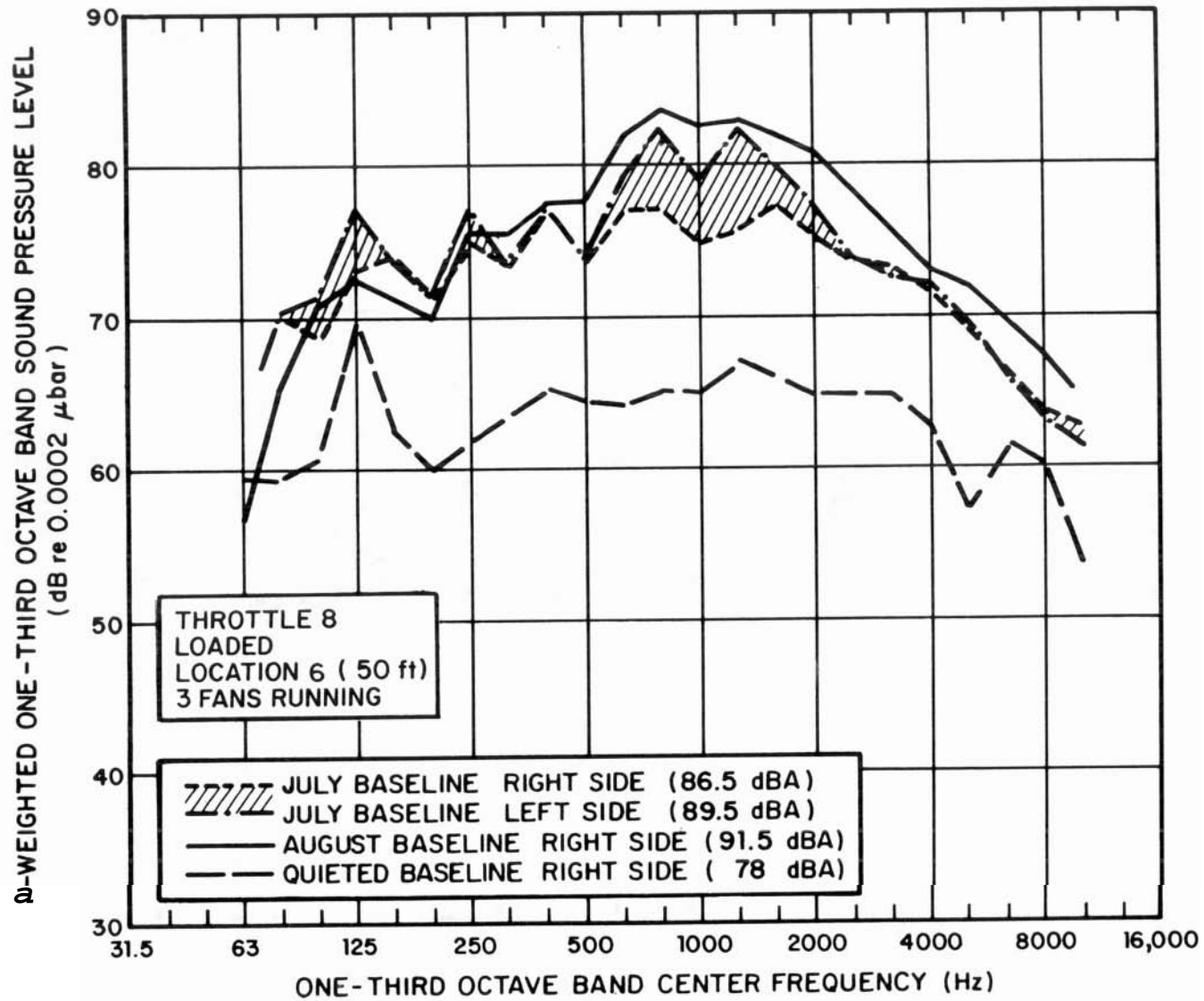

FIG. A.18. LOCOMOTIVE BASELINE NOISE, THROTTLE 8, FULL LOAD, MICROPHONE LOCATION 6.

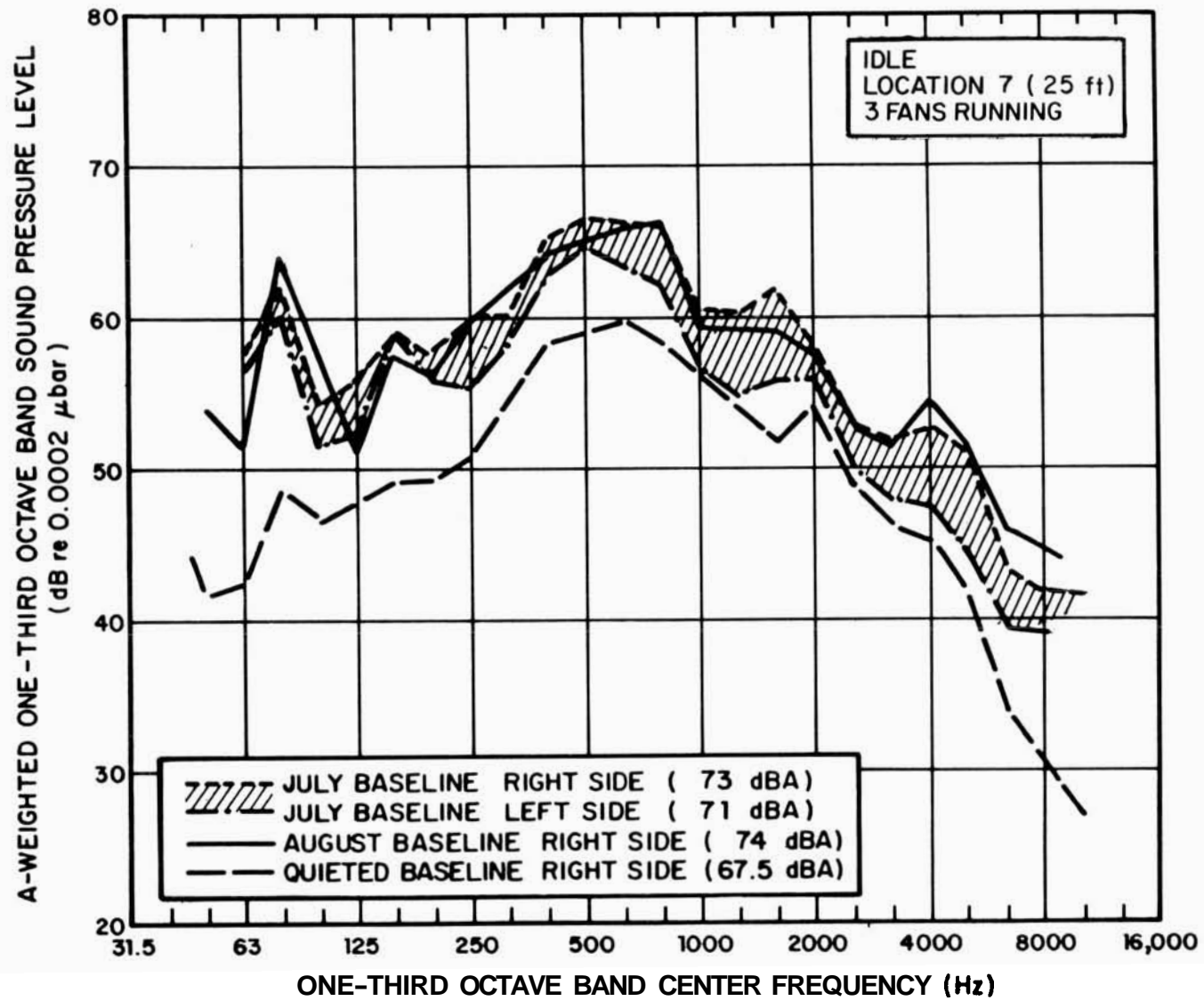

FIG. A.19. LOCOMOTIVE BASELINE NOISE, IDLE, MICROPHONE LOCATION 7.

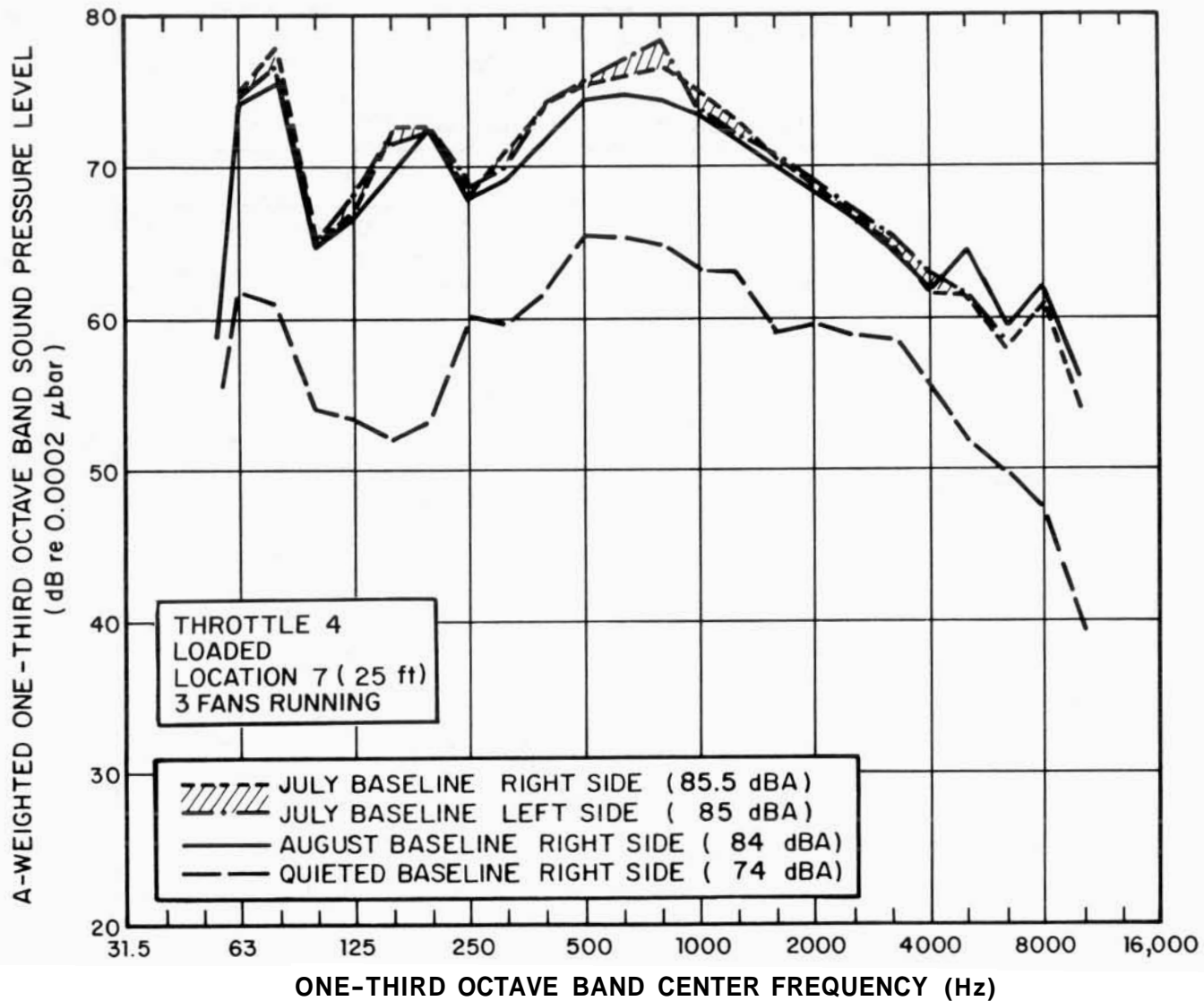

FIG. A.20. LOCOMOTIVE BASELINE NOISE, THROTTLE 4, FULL LOAD, MICROPHONE LOCATION 7.



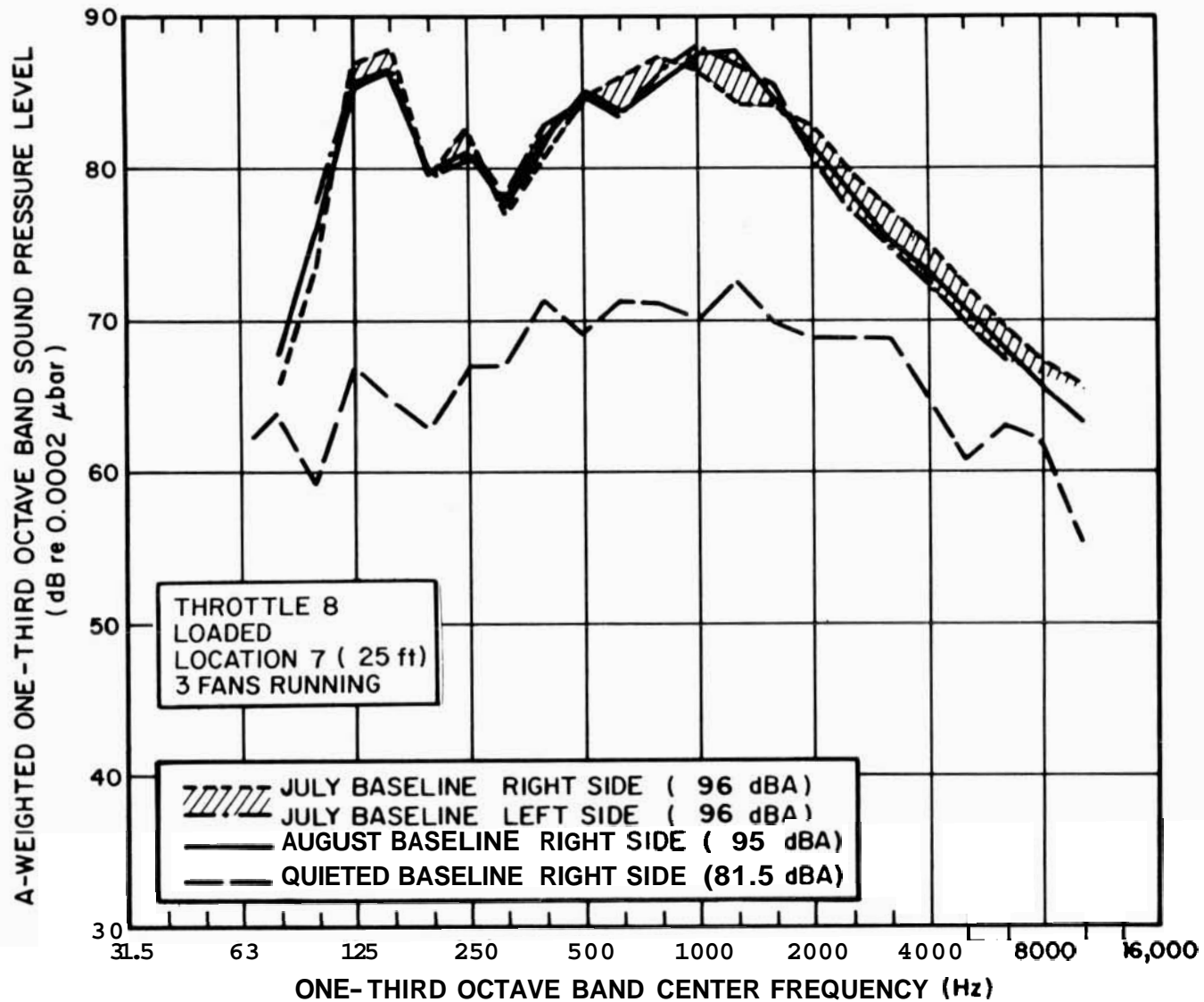

FIG. A.21. LOCOMOTIVE BASELINE NOISE, THROTTLE 8, FULL LOAD, MICROPHONE LOCATION 7.

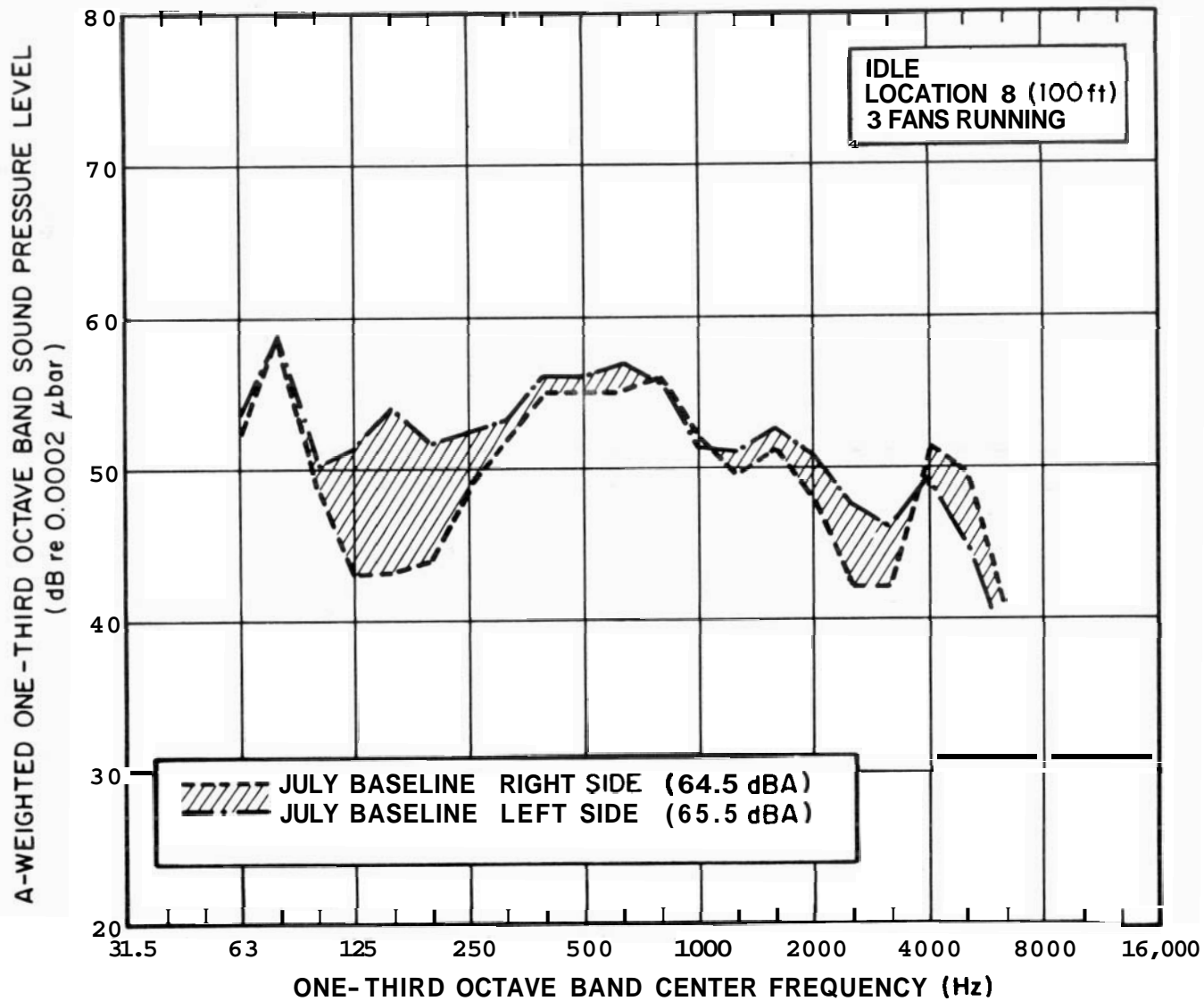

FIG. A.22 LOCOMOTIVE BASELINE NOISE, IDLE, MICROPHONE LOCATION 8.

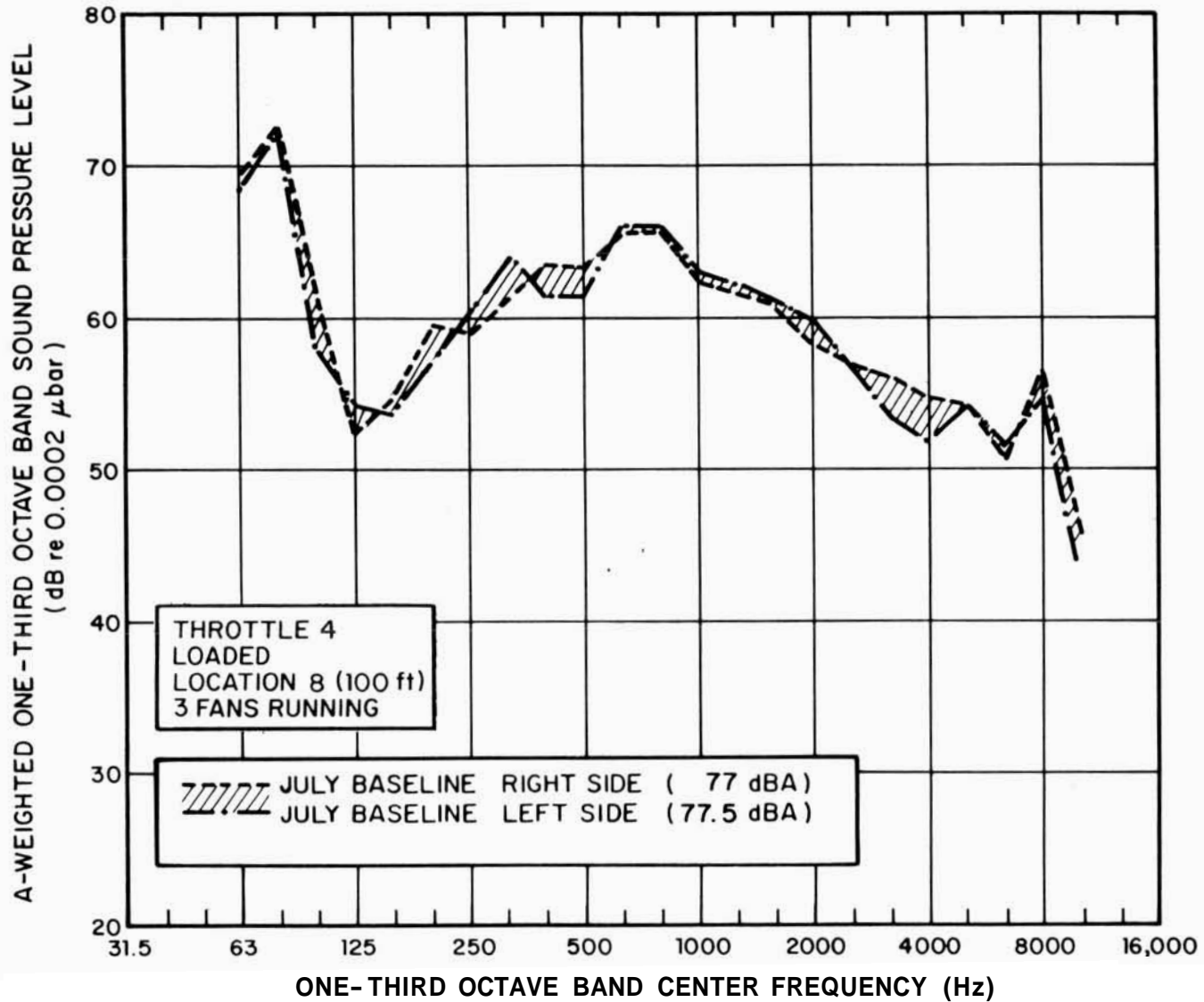

FIG. A.23. LOCOMOTIVE BASELINE NOISE, THROTTLE 4, FULL LOAD, MICROPHONE LOCATION 8.

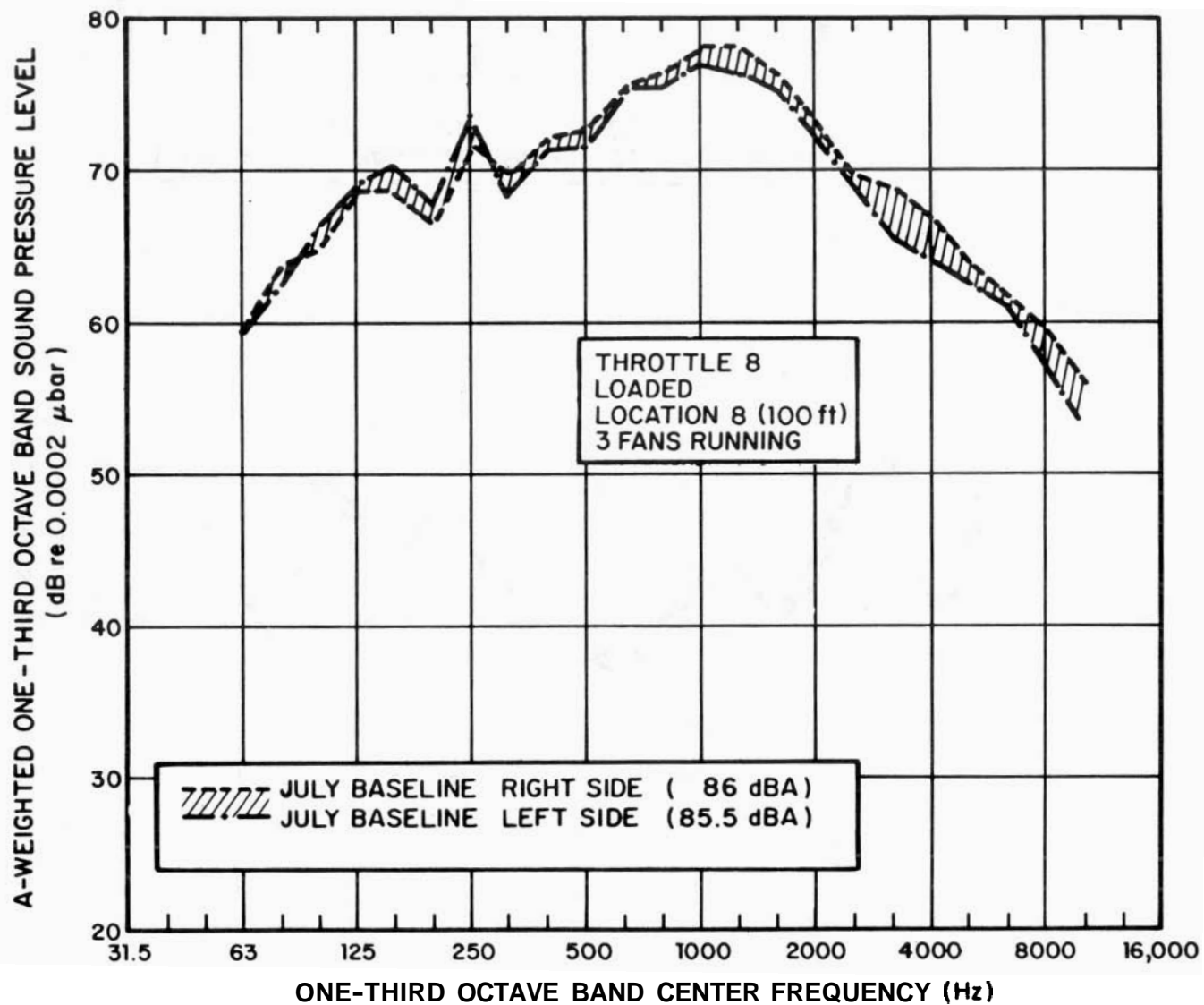

FIG. A.24. LOCOMOTIVE BASELINE NOISE, THROTTLE 8, FULL LOAD, MICROPHONE LOCATION 8.

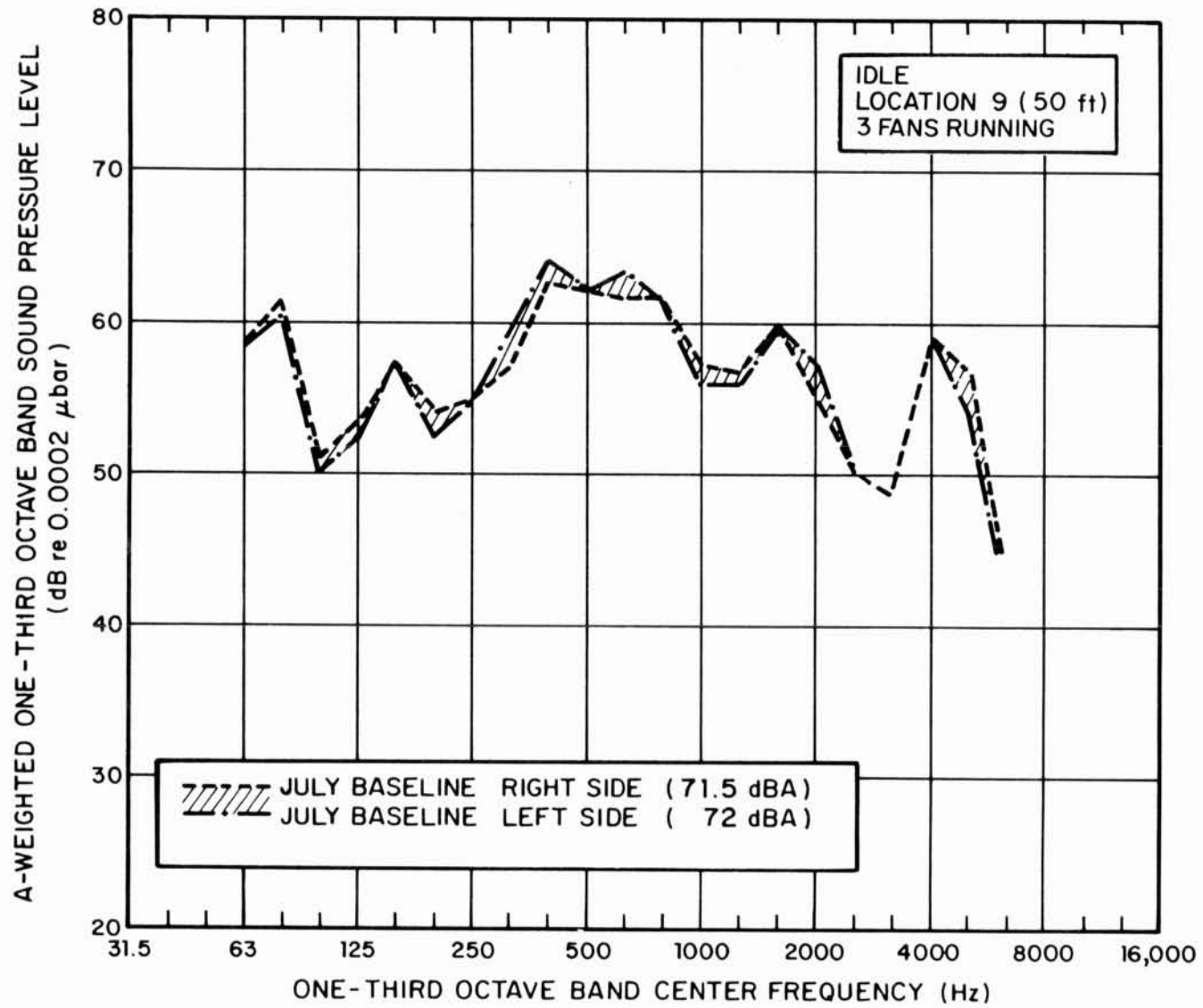

FIG. A.25. LOCOMOTIVE BASELINE NOISE, IDLE, MICROPHONE LOCATION 9.

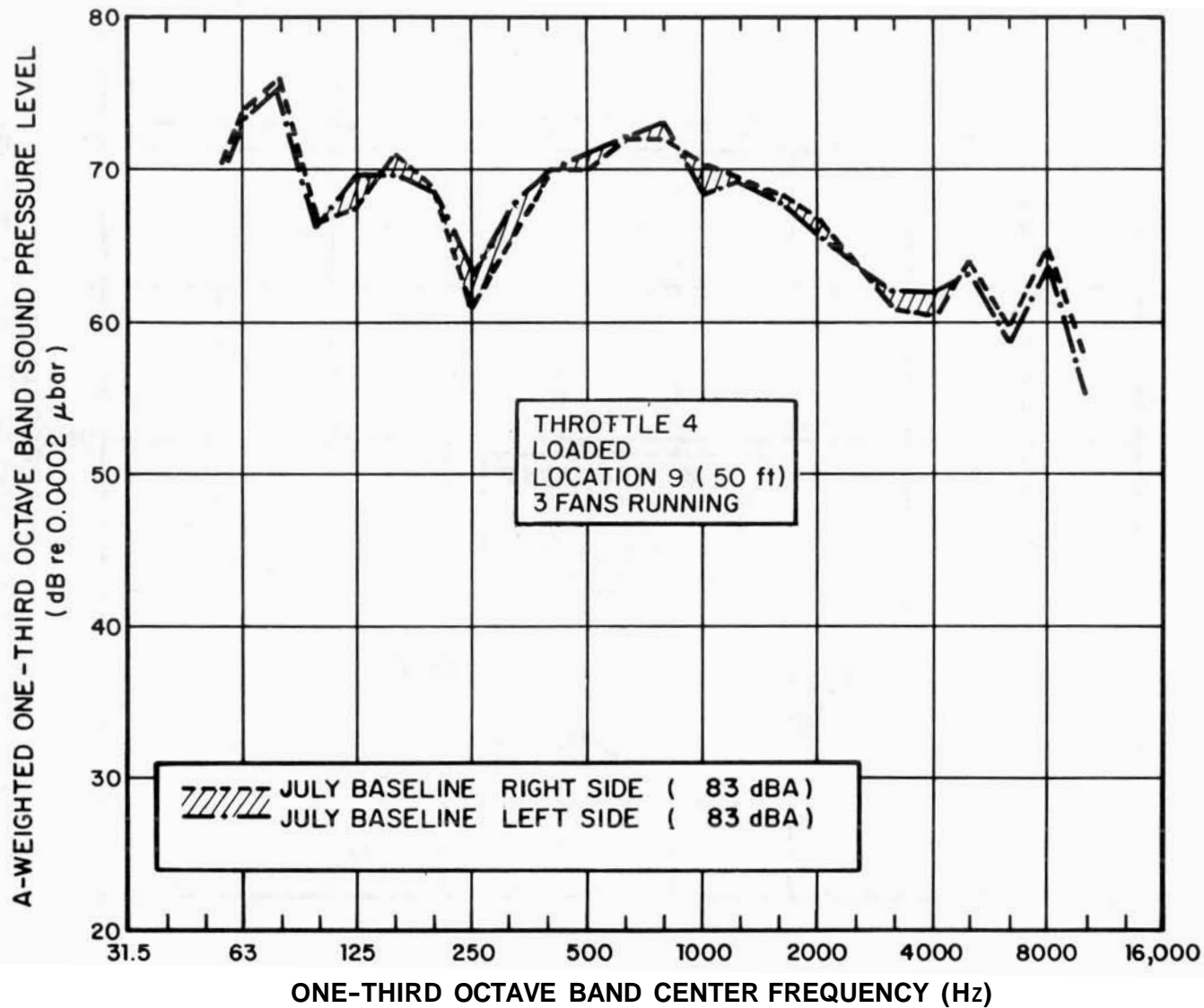

FIG. A.26. LOCOMOTIVE BASELINE NOISE, THROTTLE 4, FULL LOAD, MICROPHONE LOCATION 9.

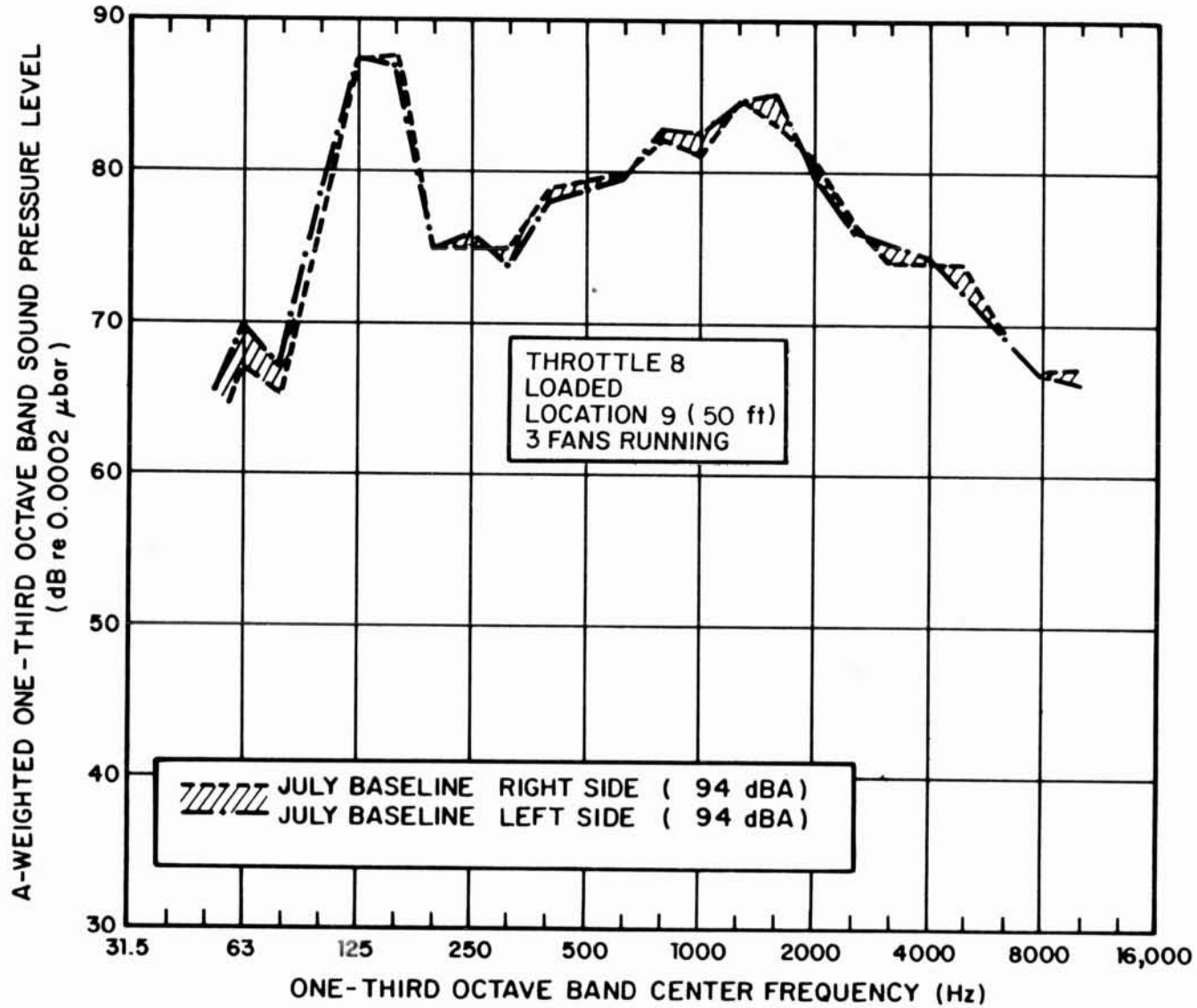

FIG. A.27. LOCOMOTIVE BASELINE NOISE, THROTTLE 8, FULL LOAD, MICROPHONE LOCATION 9.

105/106

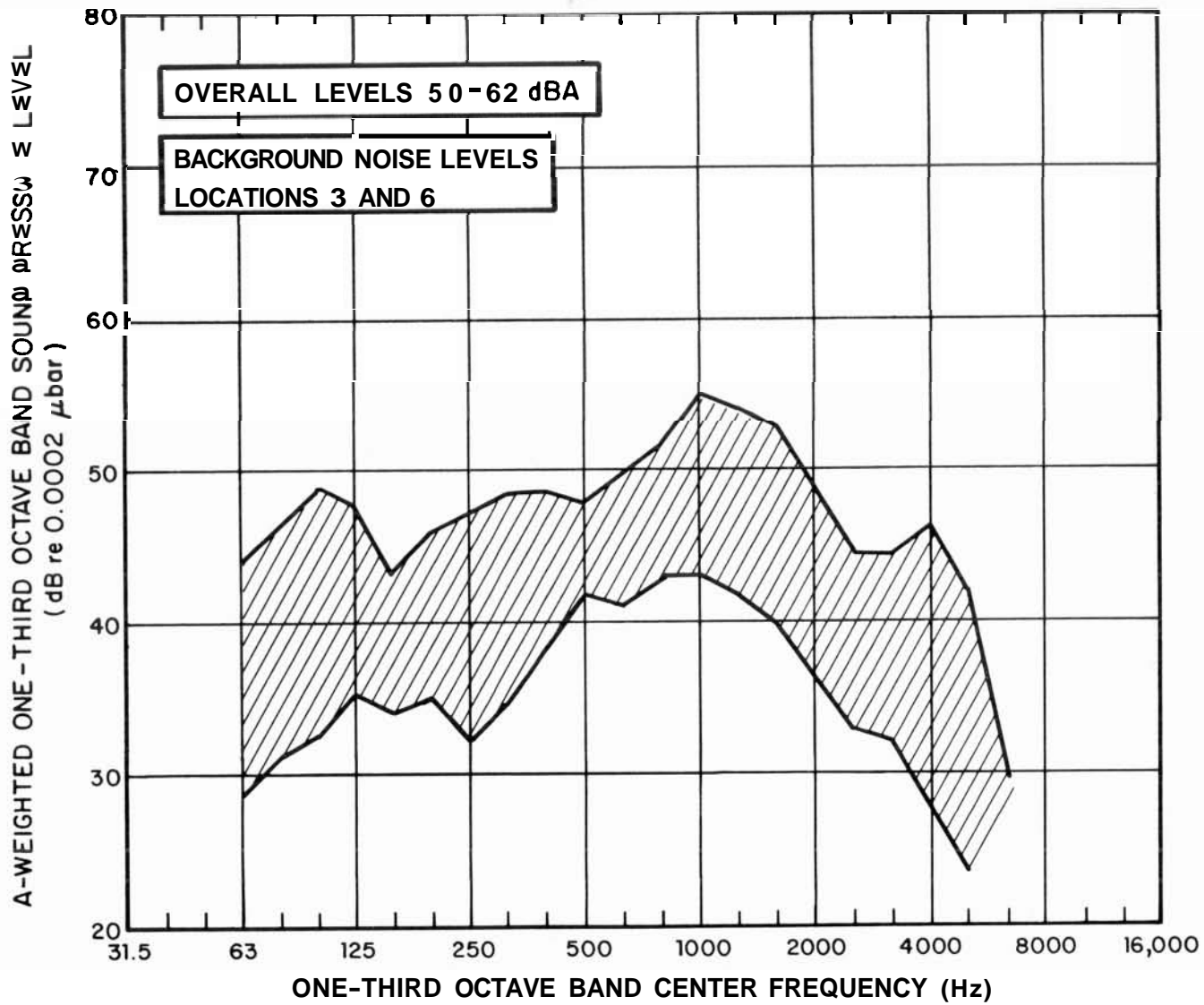

FIG. A.28. THE RANGE OF BACKGROUND LEVELS AT MICROPHONE LOCATIONS 3 AND 6.





APPENDIX B  
DIAGNOSTIC MEASUREMENT SOURCE SPECTRA

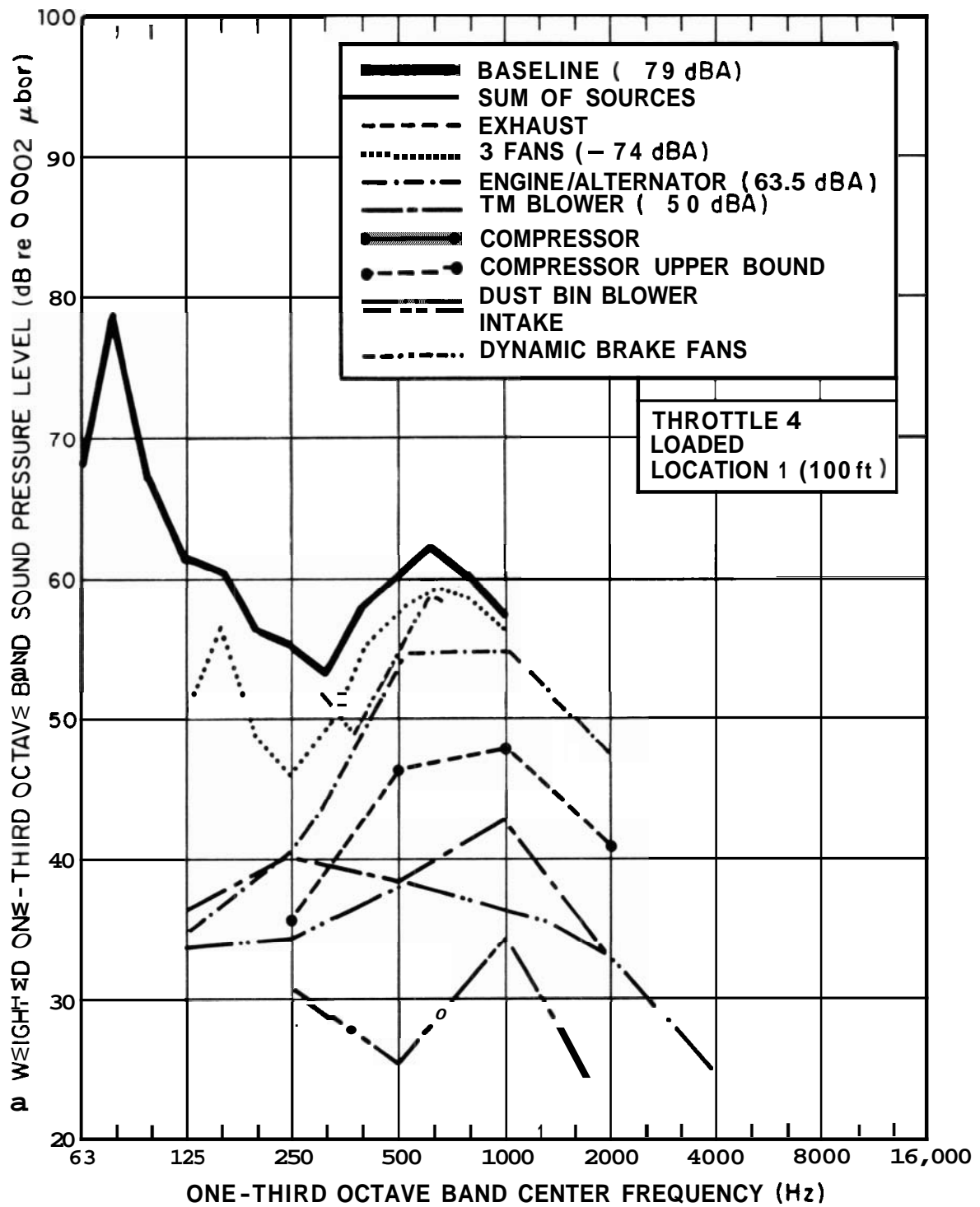

FIG. B.1. SOURCE SPECTRA AT THROTTLE 4, FULL LOAD, MICROPHONE LOCATION 1.

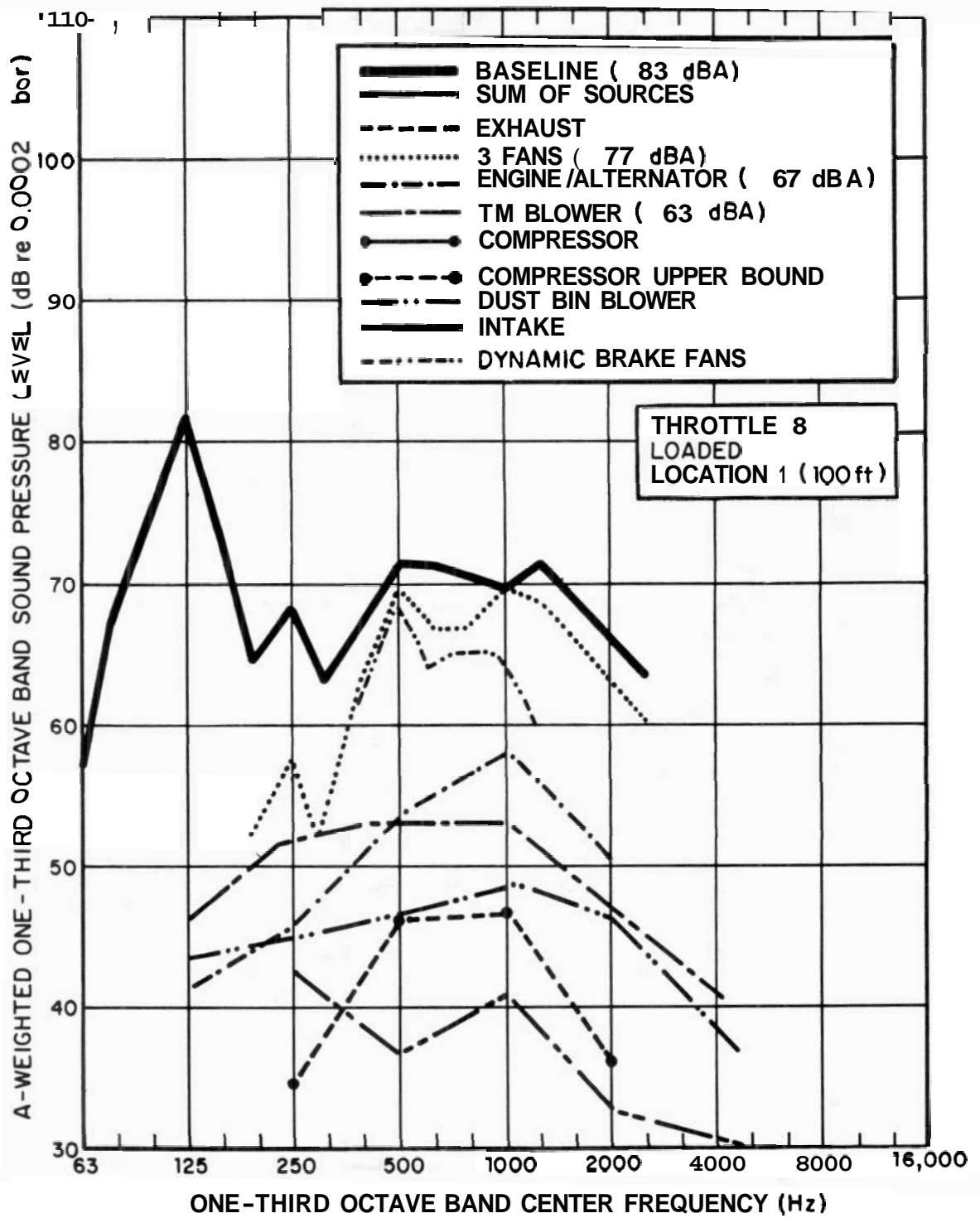

FIG. B.2. SOURCE SPECTRA AT THROTTLE 8, FULL LOAD, MICROPHONE LOCATION 1.

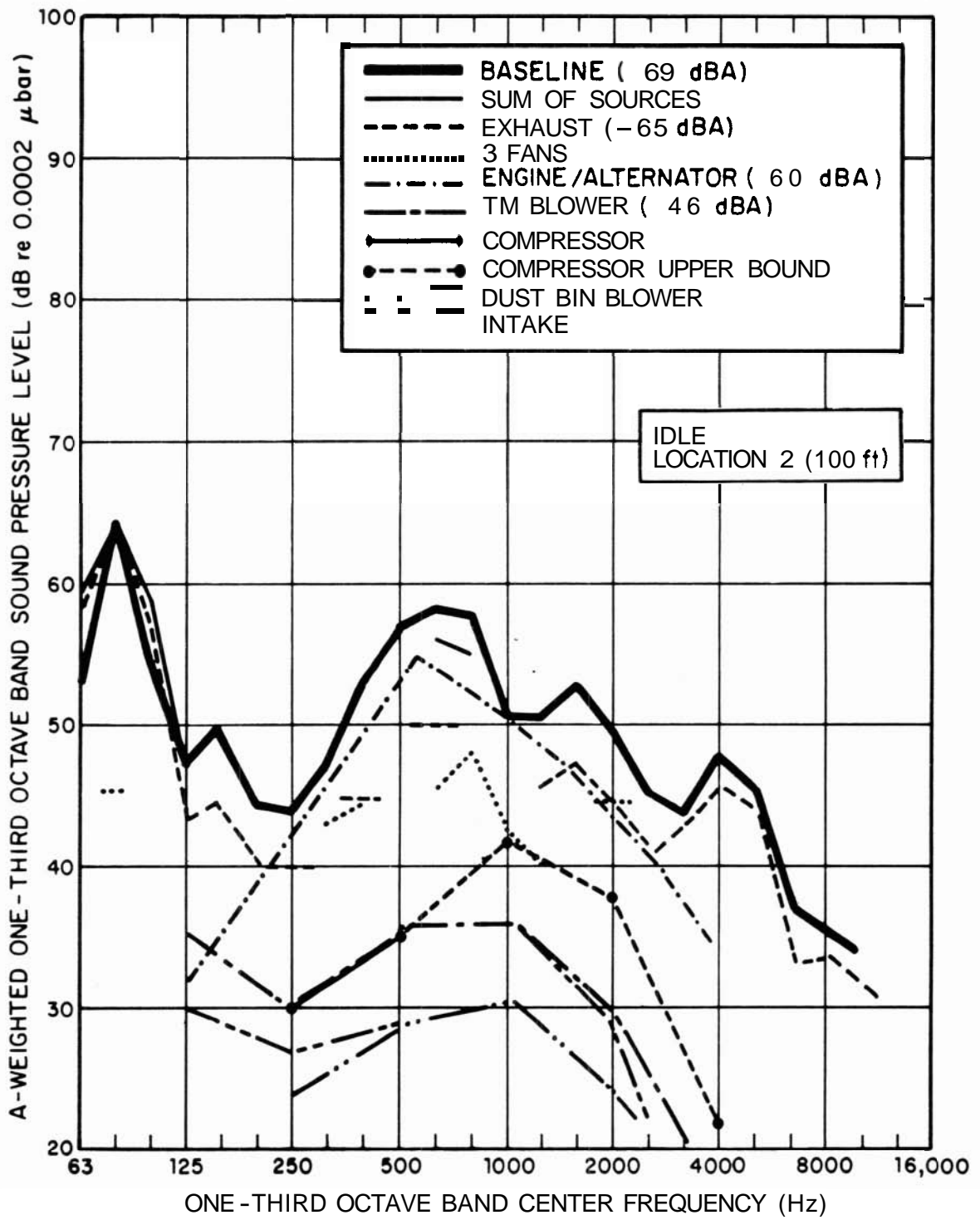

FIG. 8.3. SOURCE SPECTRA AT IDLE, MICROPHONE LOCATION 2.

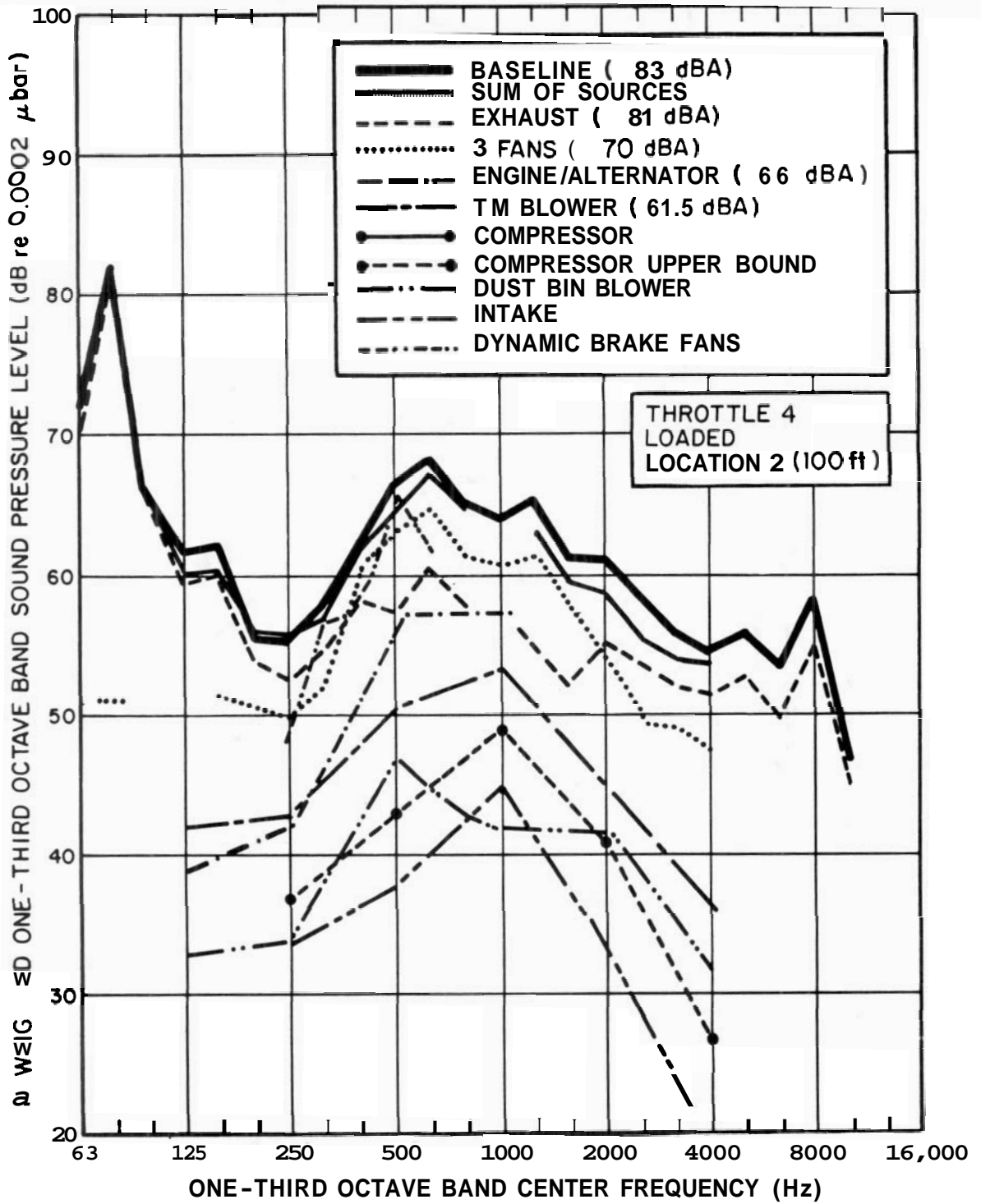

FIG. B.4. SOURCE SPECTRA AT THROTTLE 4, FULL LOAD, MICROPHONE LOCATION 2.

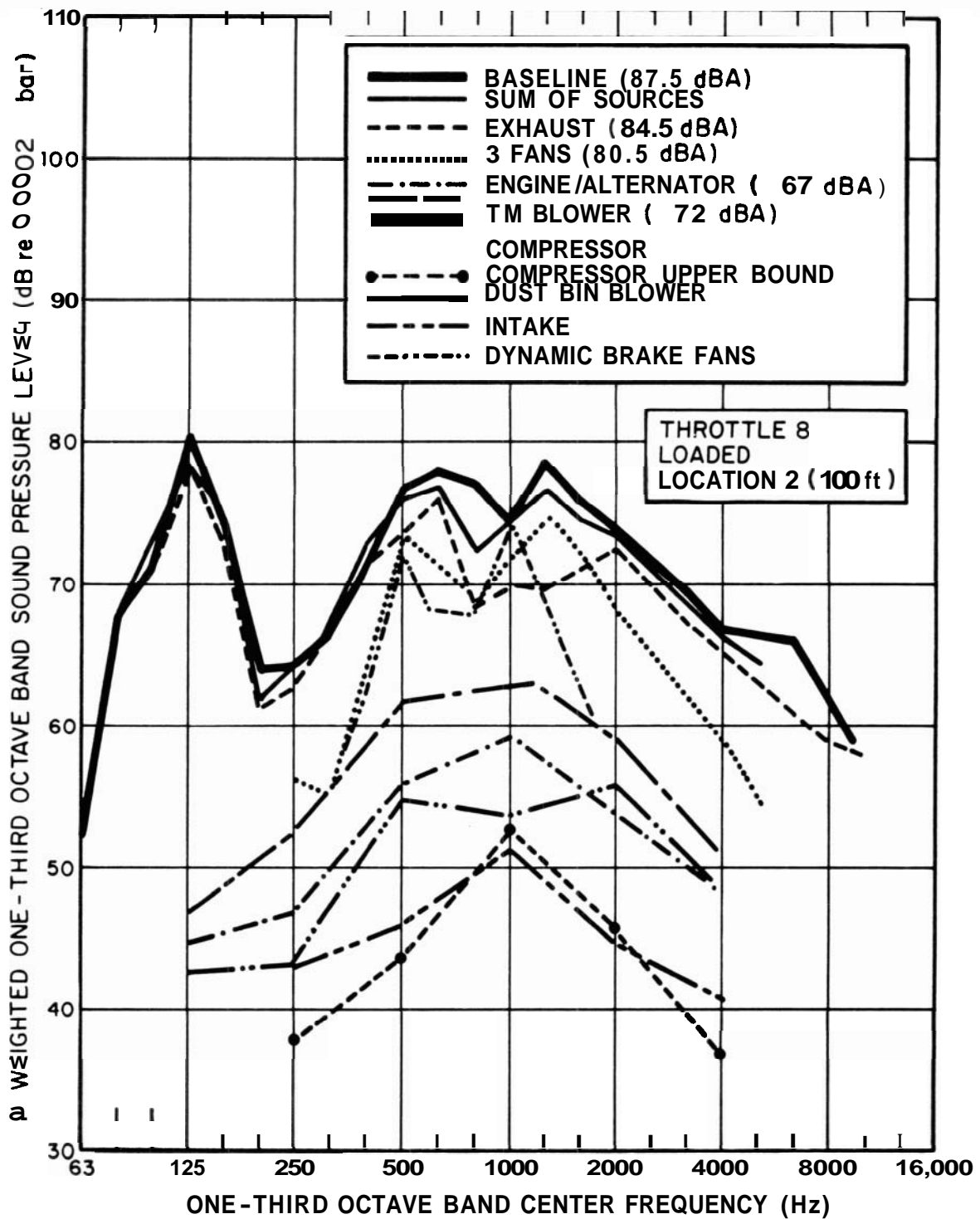

FIG. B.5. SOURCE SPECTRA AT THROTTLE 8, FULL LOAD, MICROPHONE LOCATION 2.

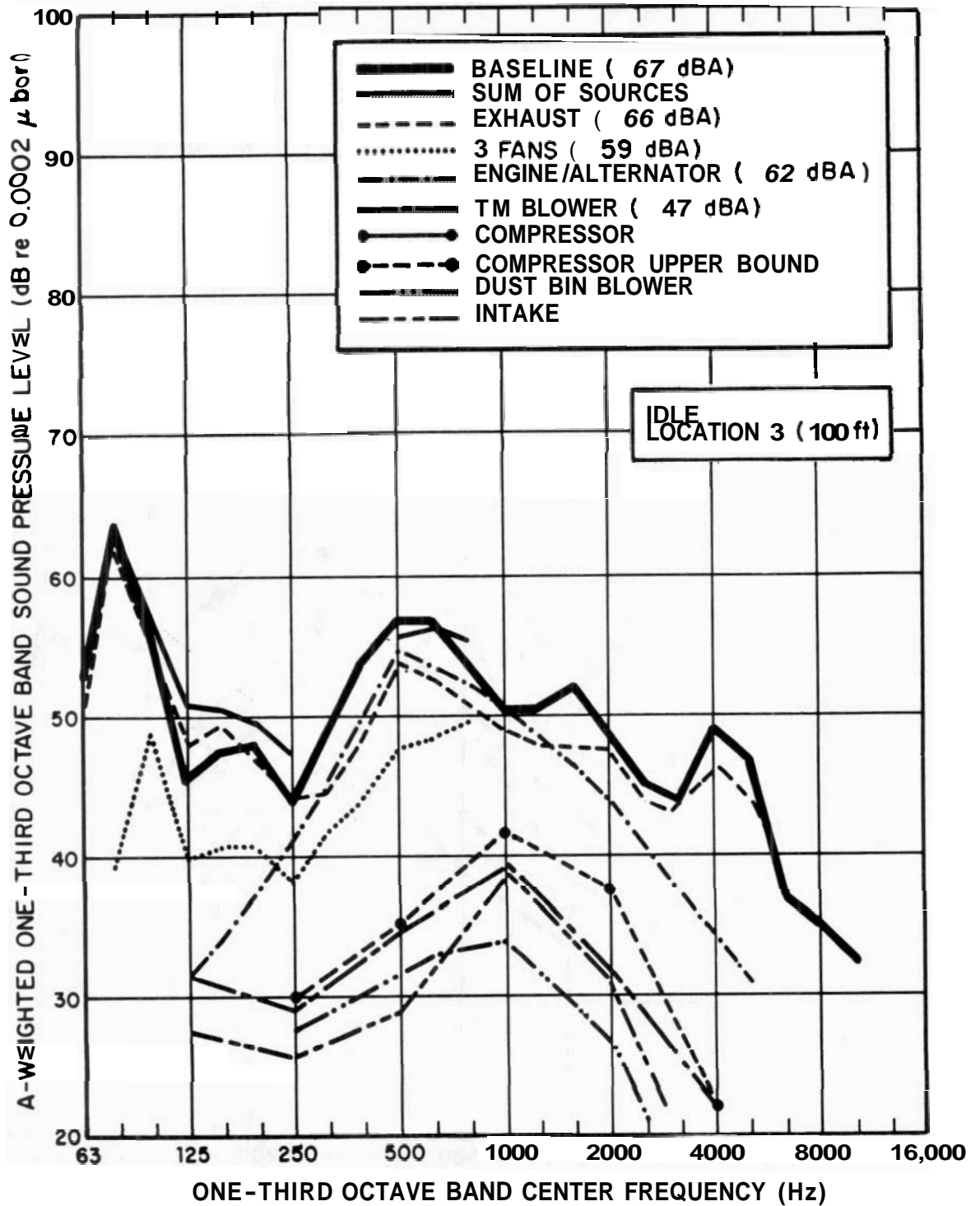

FIG. B.6. SOURCE SPECTRA AT IDLE, MICROPHONE LOCATION 3.



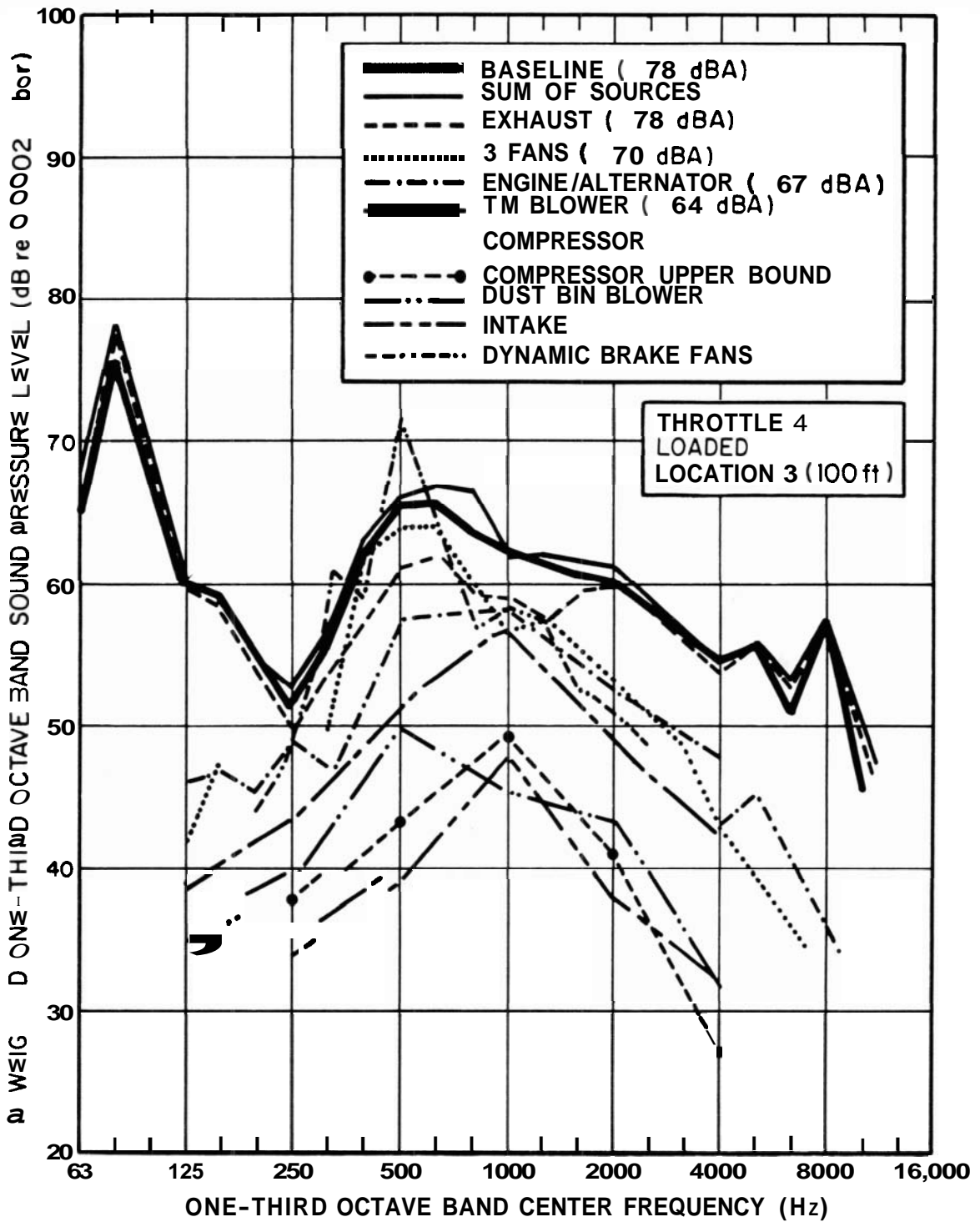

FIG. B.7. SOURCE SPECTRA AT THROTTLE 4, FULL LOAD, MICROPHONE LOCATION 3.

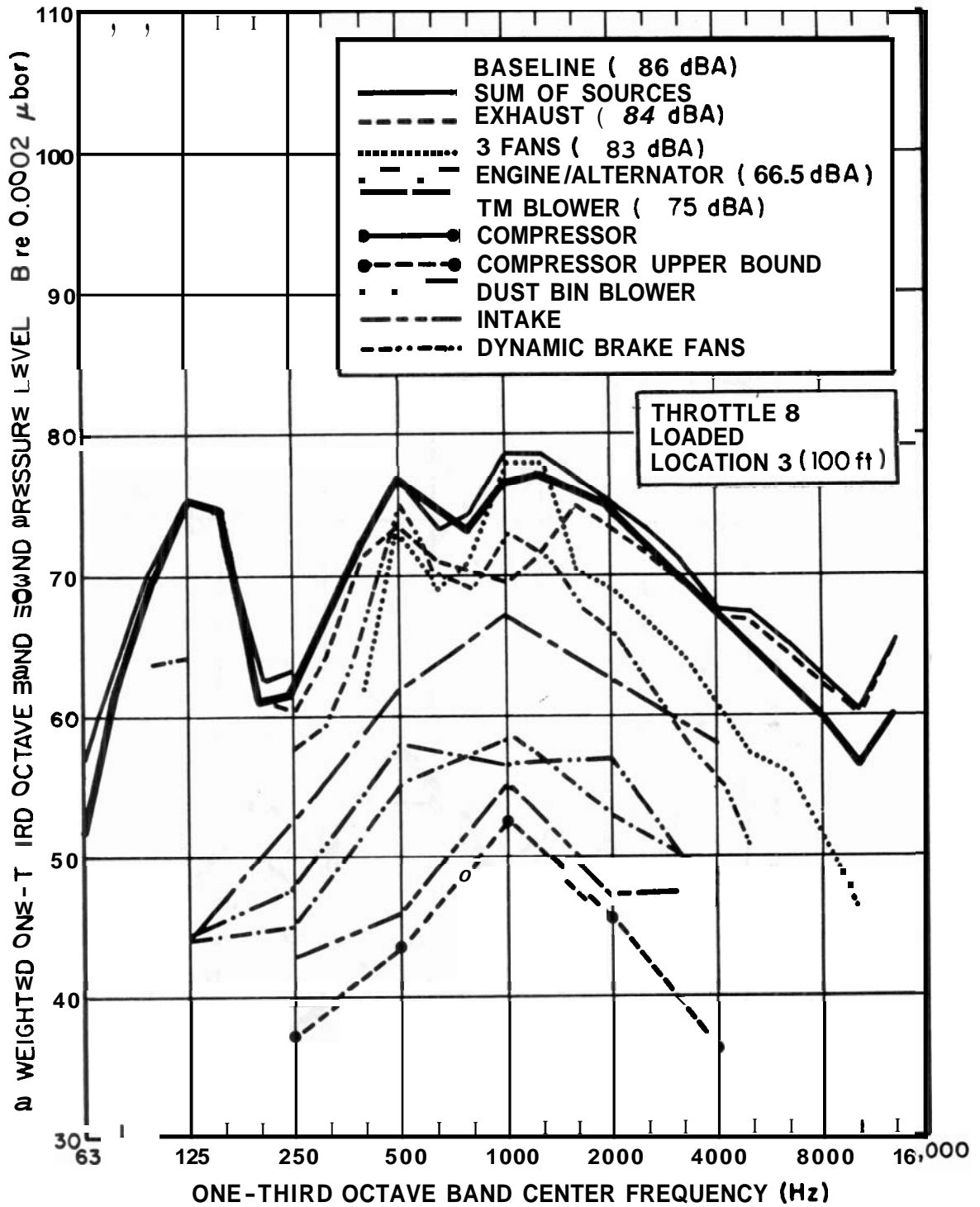

FIG. B.8. SOURCE SPECTRA AT THROTTLE 8, FULL LOAD, MICROPHONE LOCATION 3.

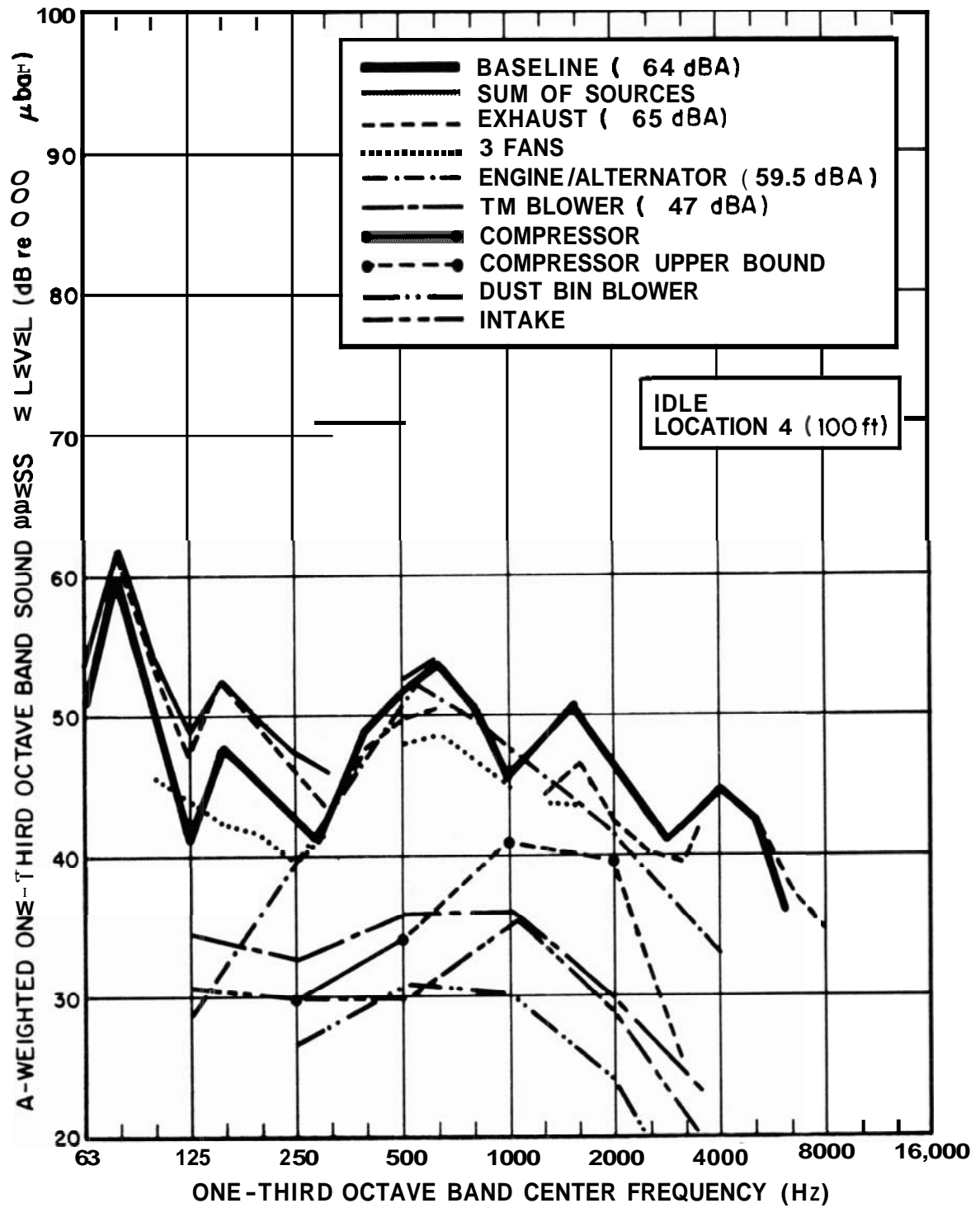

FIG. B.9. SOURCE SPECTRA AT IDLE, MICROPHONE LOCATION 4.

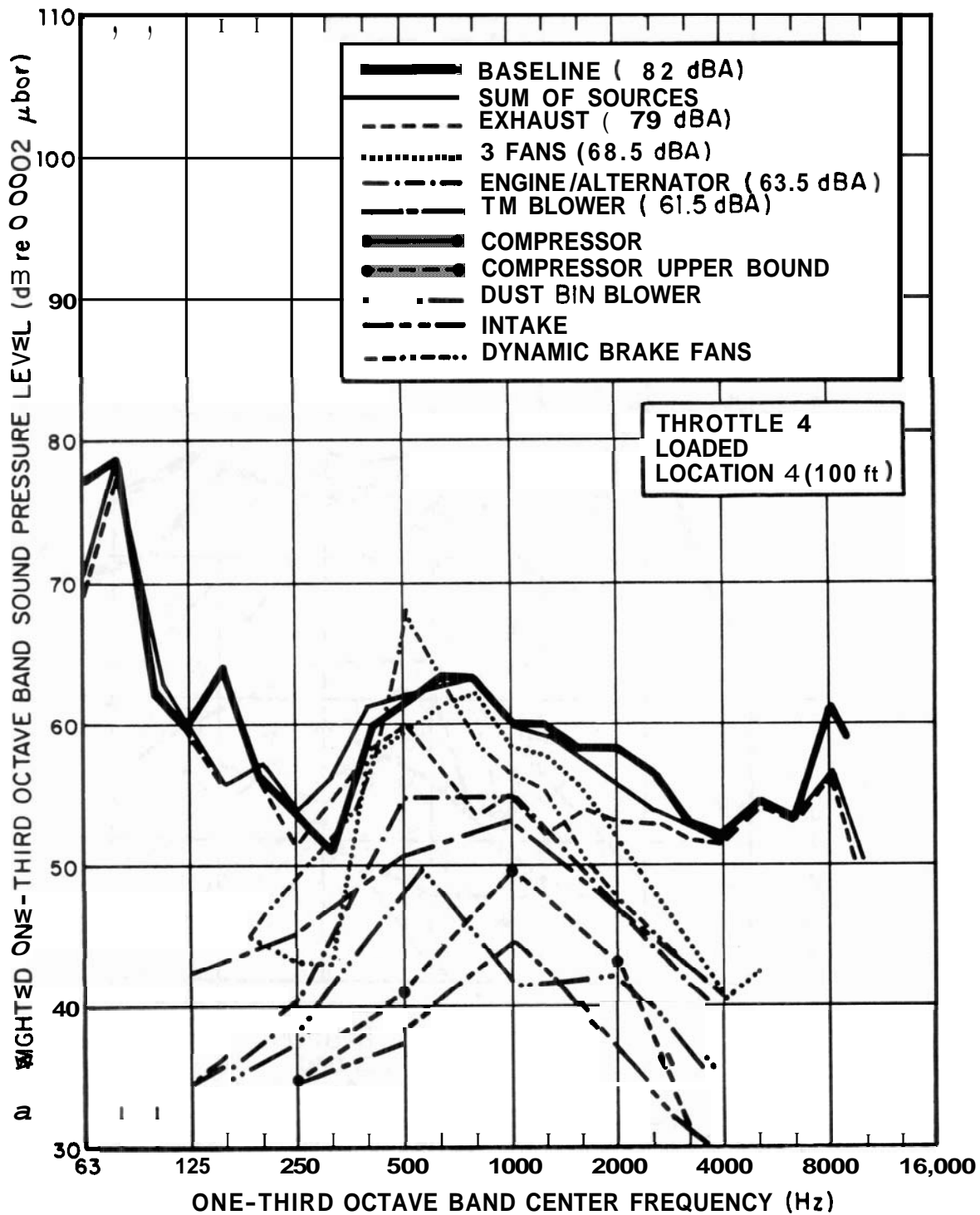

FIG. B.10. SOURCE SPECTRA AT THROTTLE 4, FULL LOAD, MICROPHONE LOCATION 4.

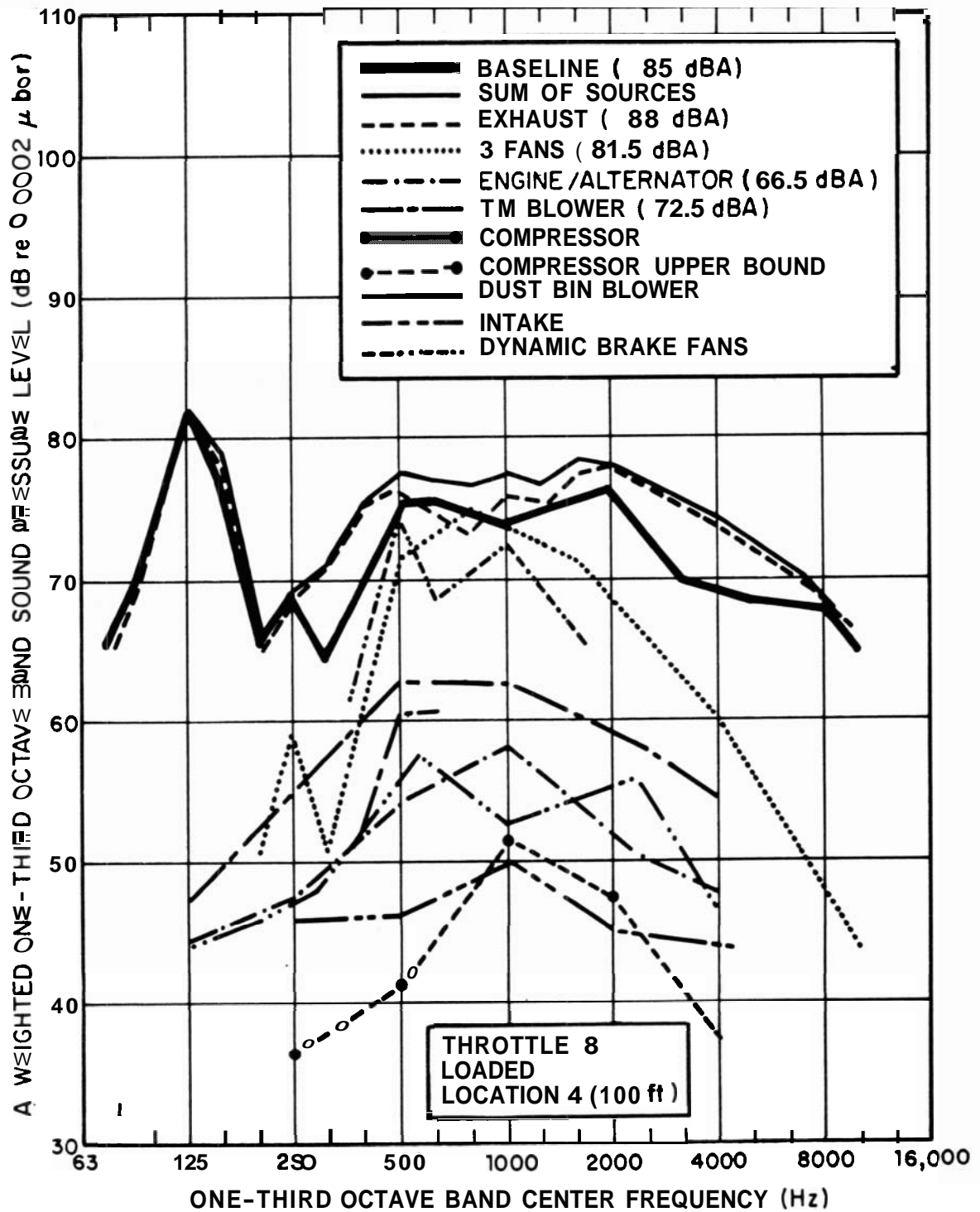

FIG. B.11. SOURCE SPECTRA, THROTTLE 8, FULL LOAD, MICROPHONE LOCATION 4.

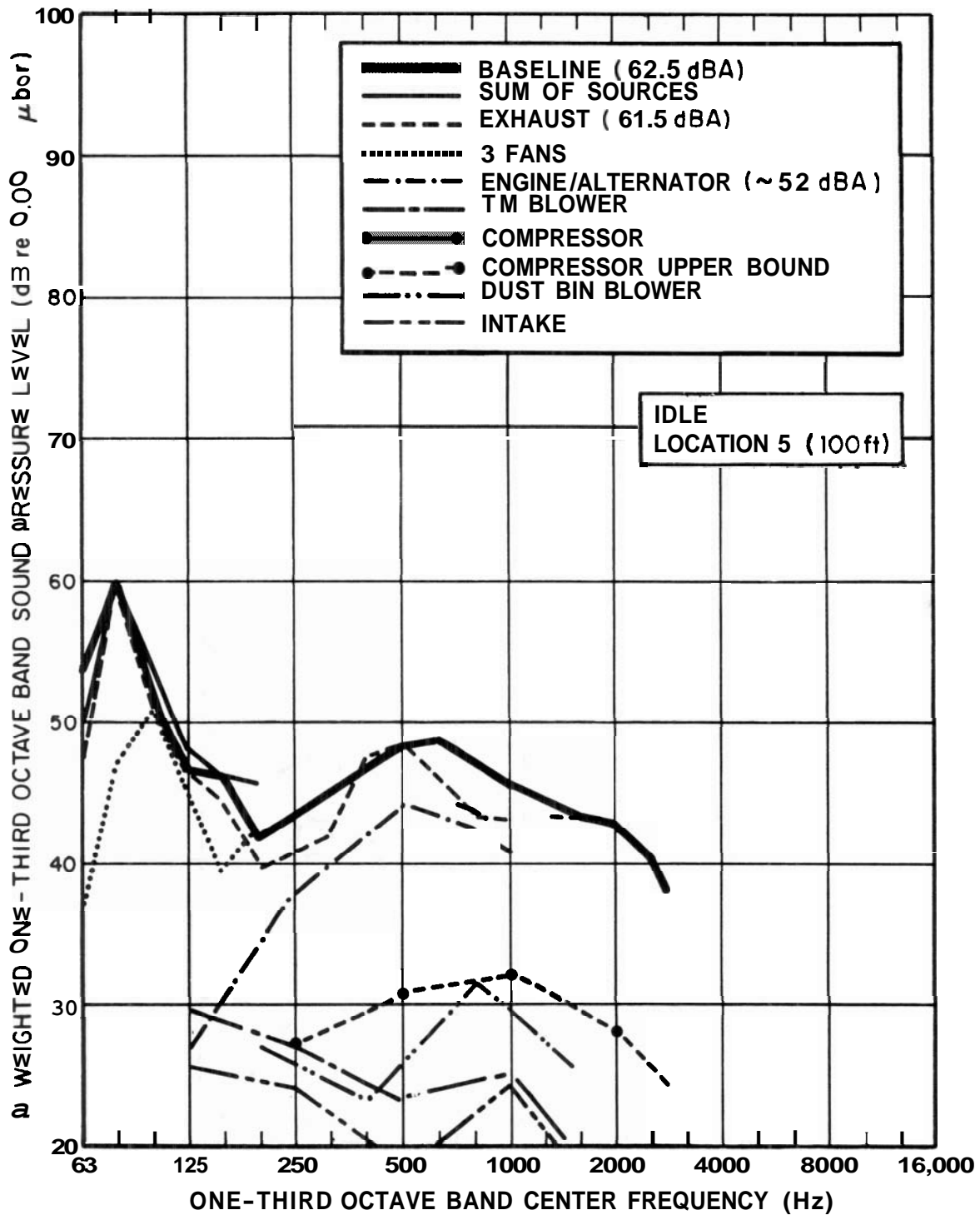

FIG. B.12. SOURCE SPECTRA, IDLE, MICROPHONE LOCATION 5.

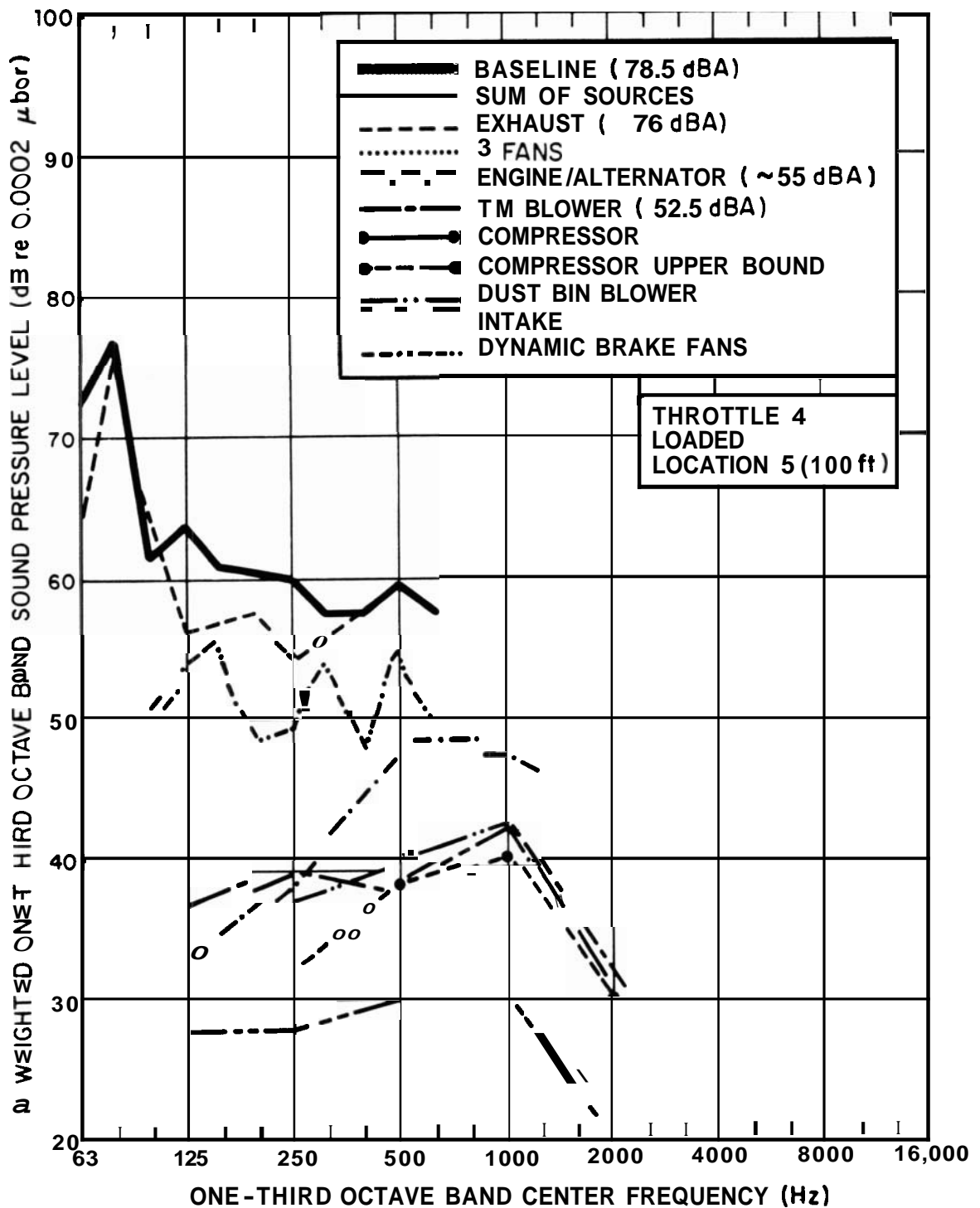

FIG. B.13. SOURCE SPECTRA, THROTTLE 4, FULL LOAD, MICROPHONE LOCATION 5.

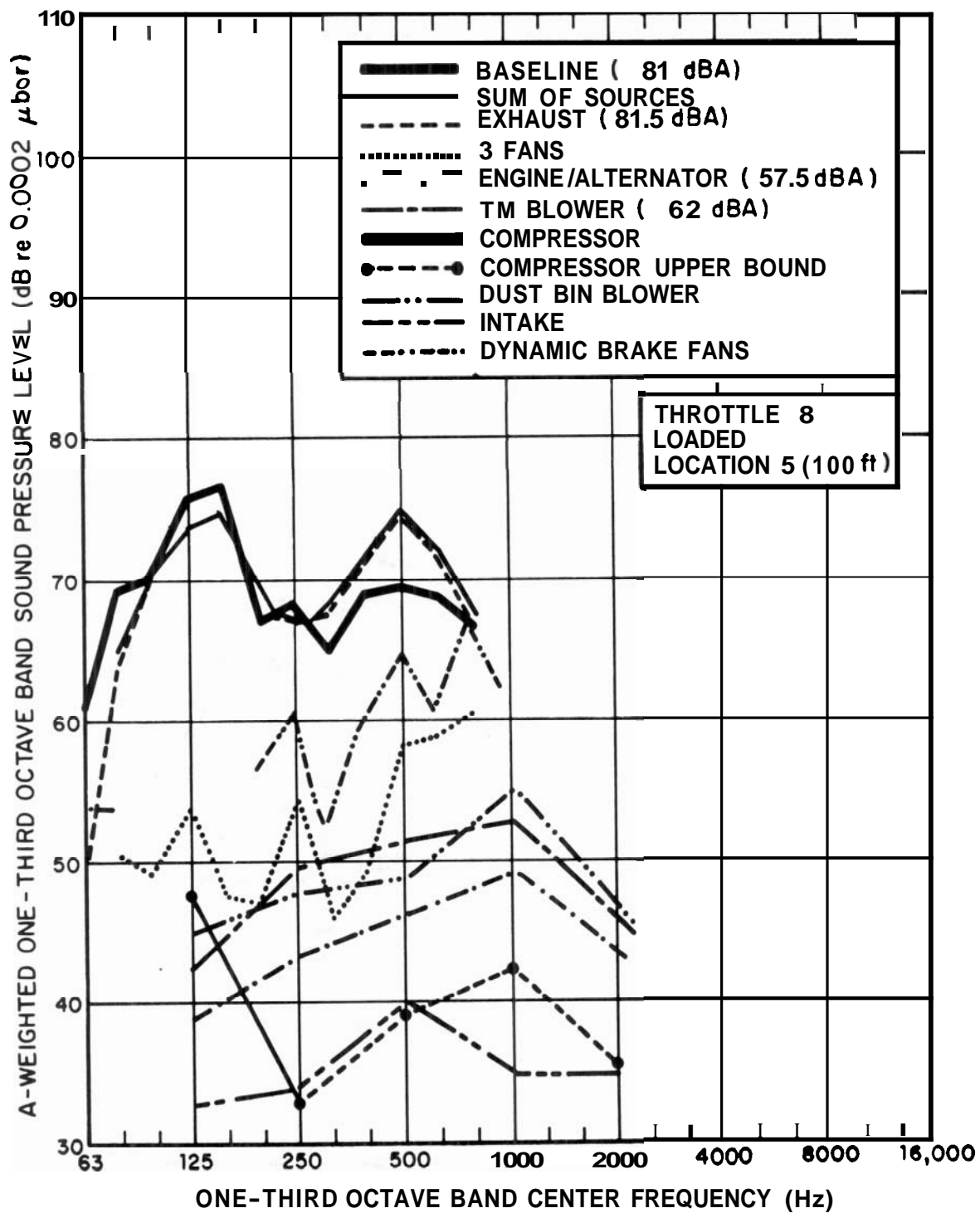

FIG. B.14. SOURCE SPECTRA, THROTTLE 8, FULL LOAD, MICROPHONE LOCATION 5.



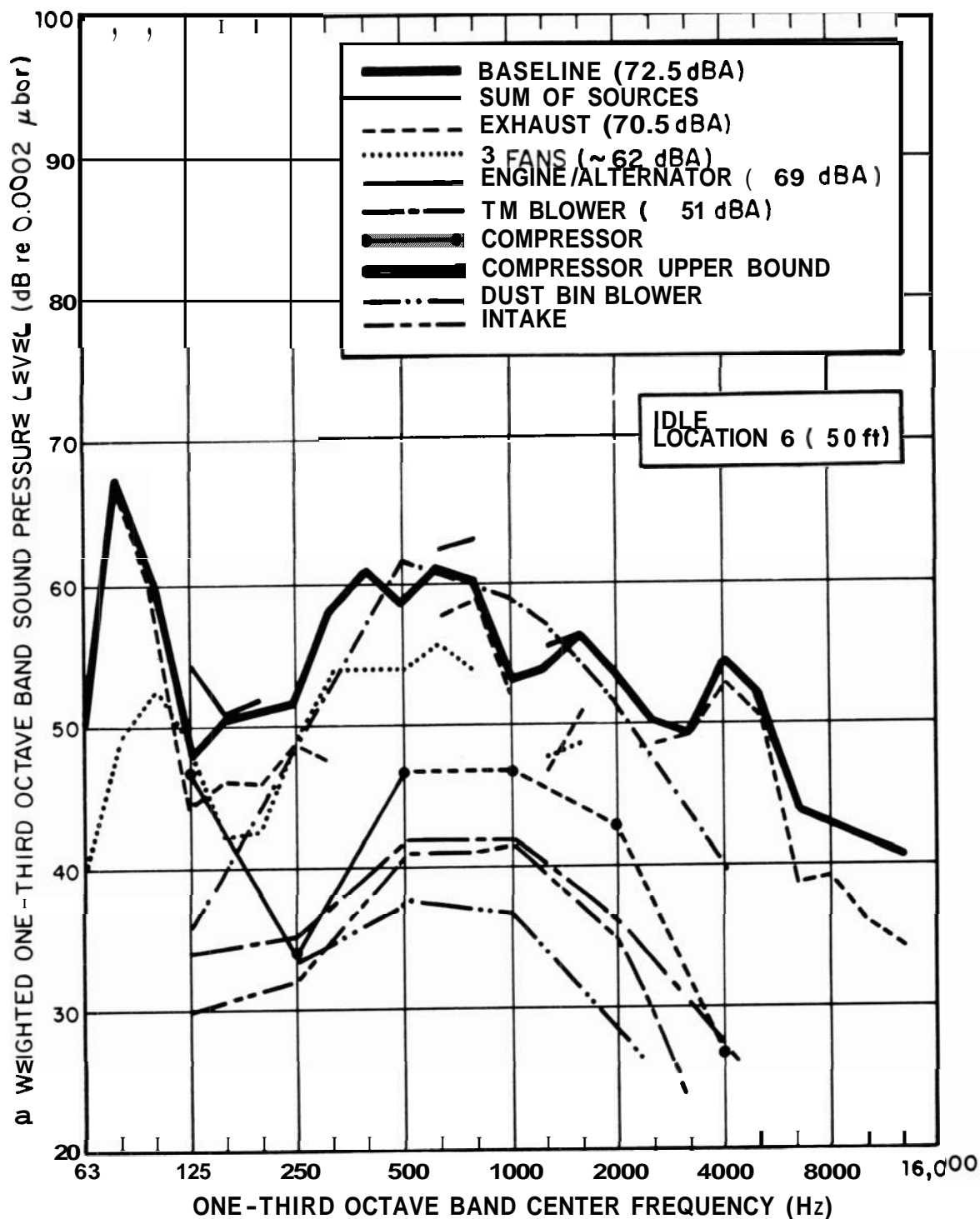

FIG. B.15. SOURCE SPECTRA, IDLE, MICROPHONE LOCATION 6.

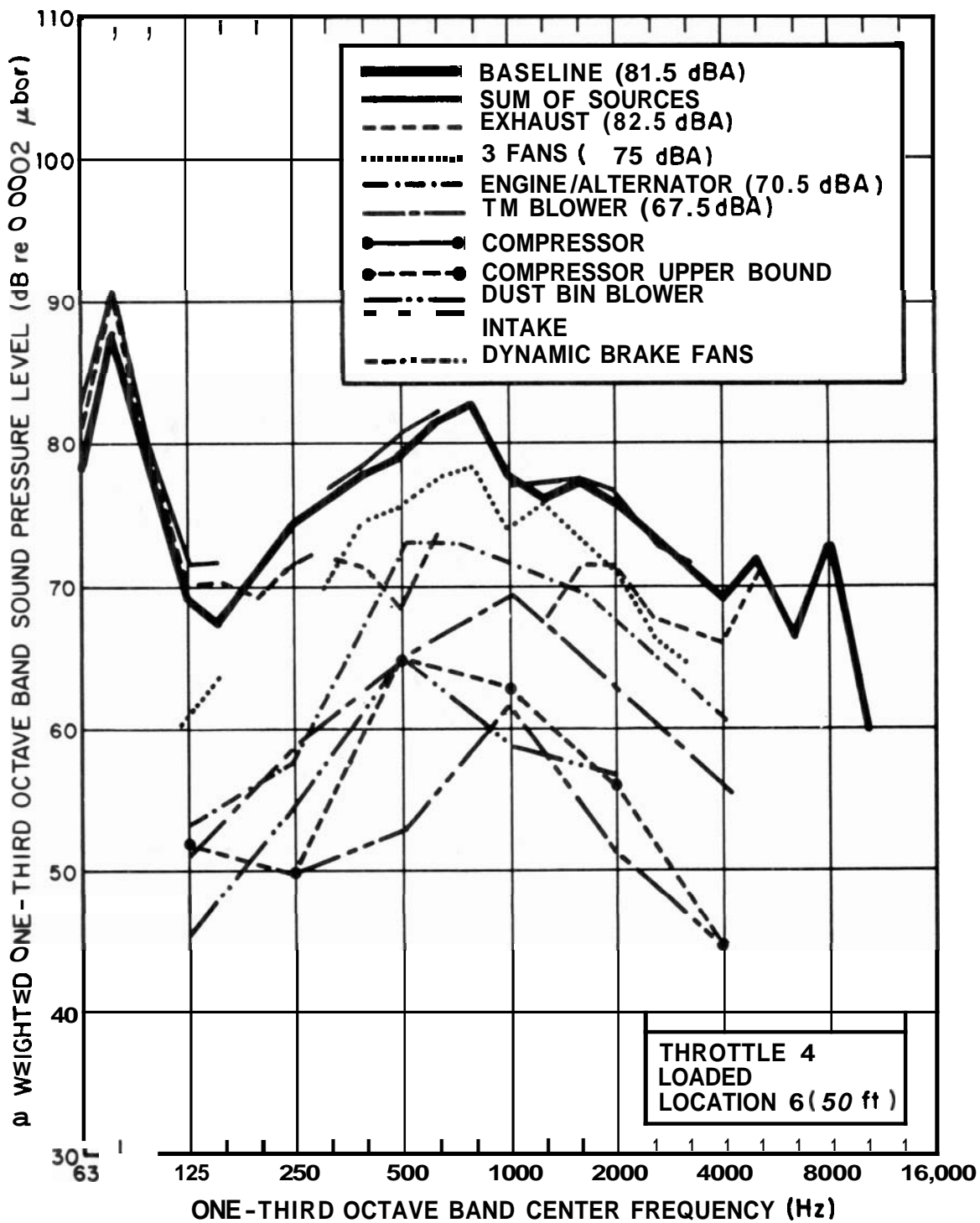

FIG. B.16. SOURCE SPECTRA, THROTTLE 4, FULL LOAD, MICROPHONE LOCATION 6.

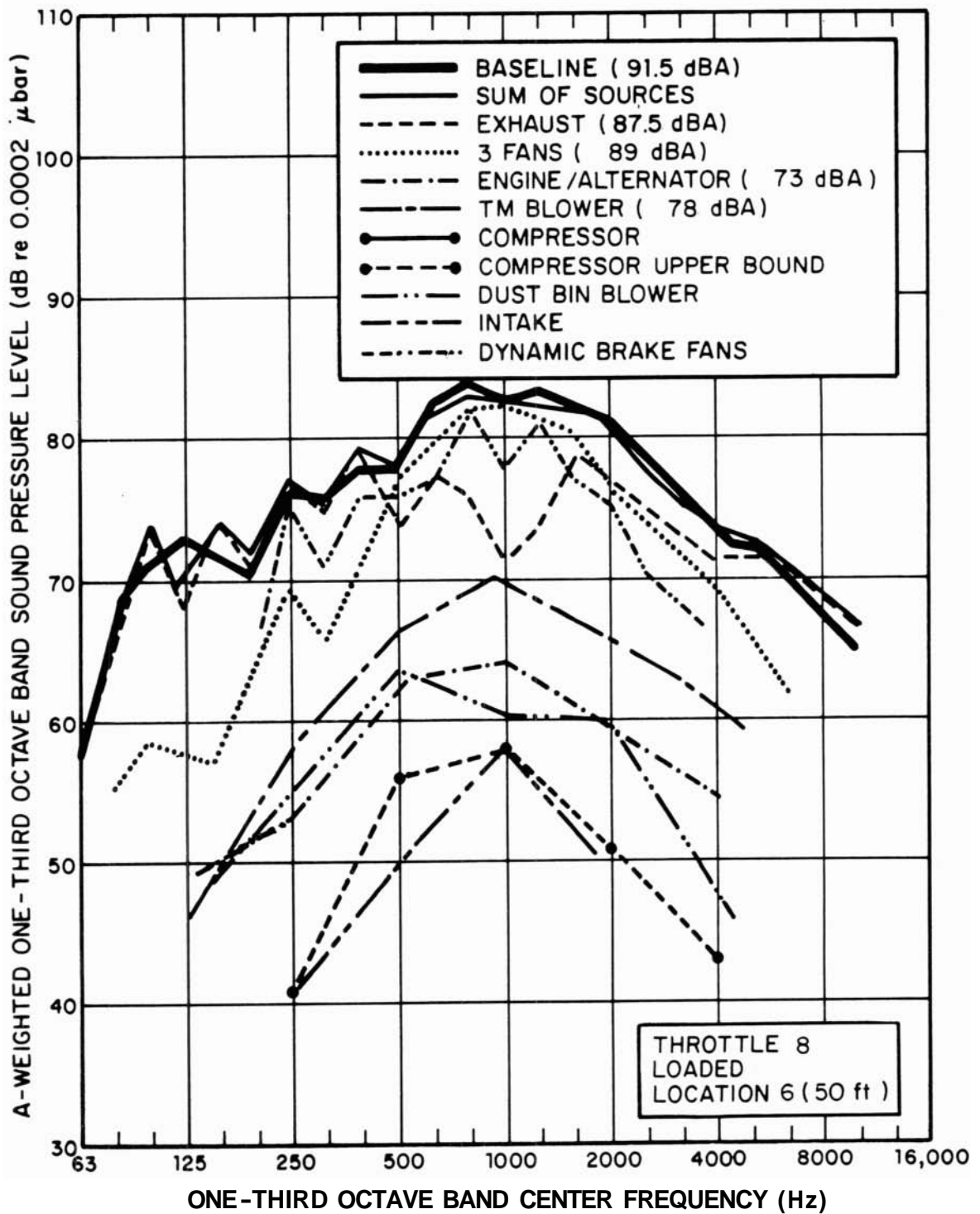

FIG. B.17. SOURCE SPECTRA, THROTTLE 8, FULL LOAD, MICROPHONE LOCATION 6.

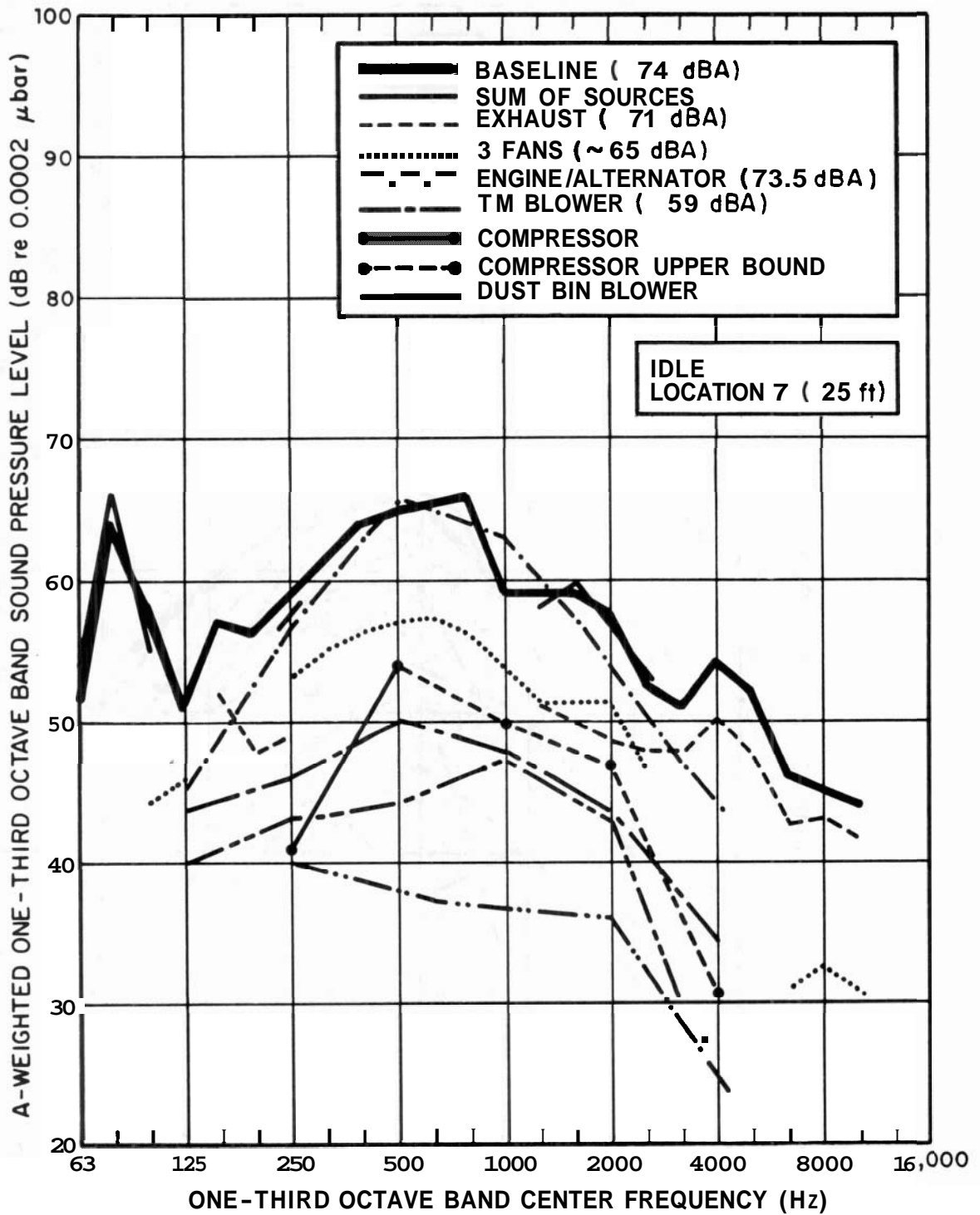

FIG. B.18. SOURCE SPECTRA, IDLE, MICROPHONE LOCATION 7.

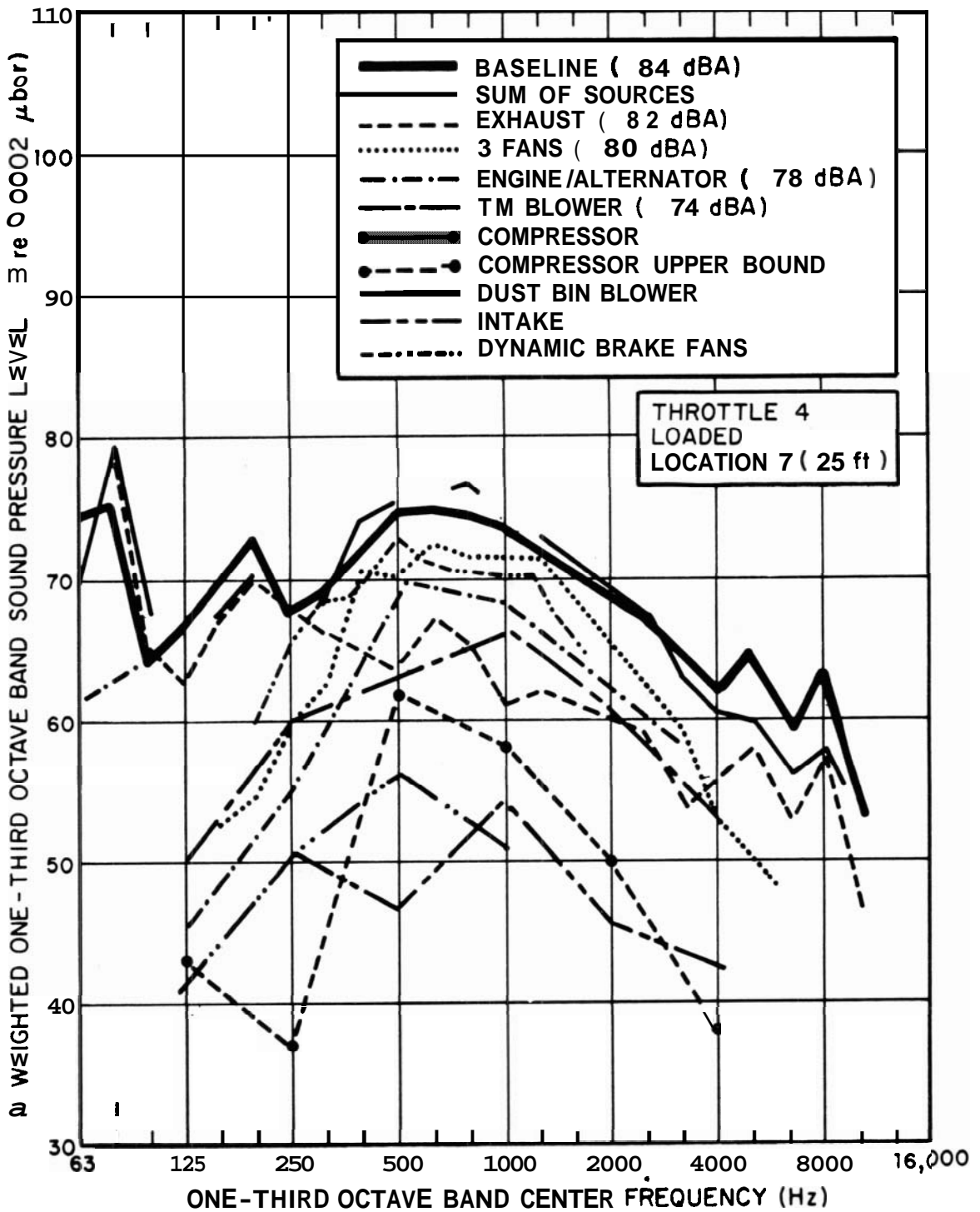

FIG. 8.19. SOURCE SPECTRA, THROTTLE 4, FULL LOAD, MICROPHONE LOCATION 7.

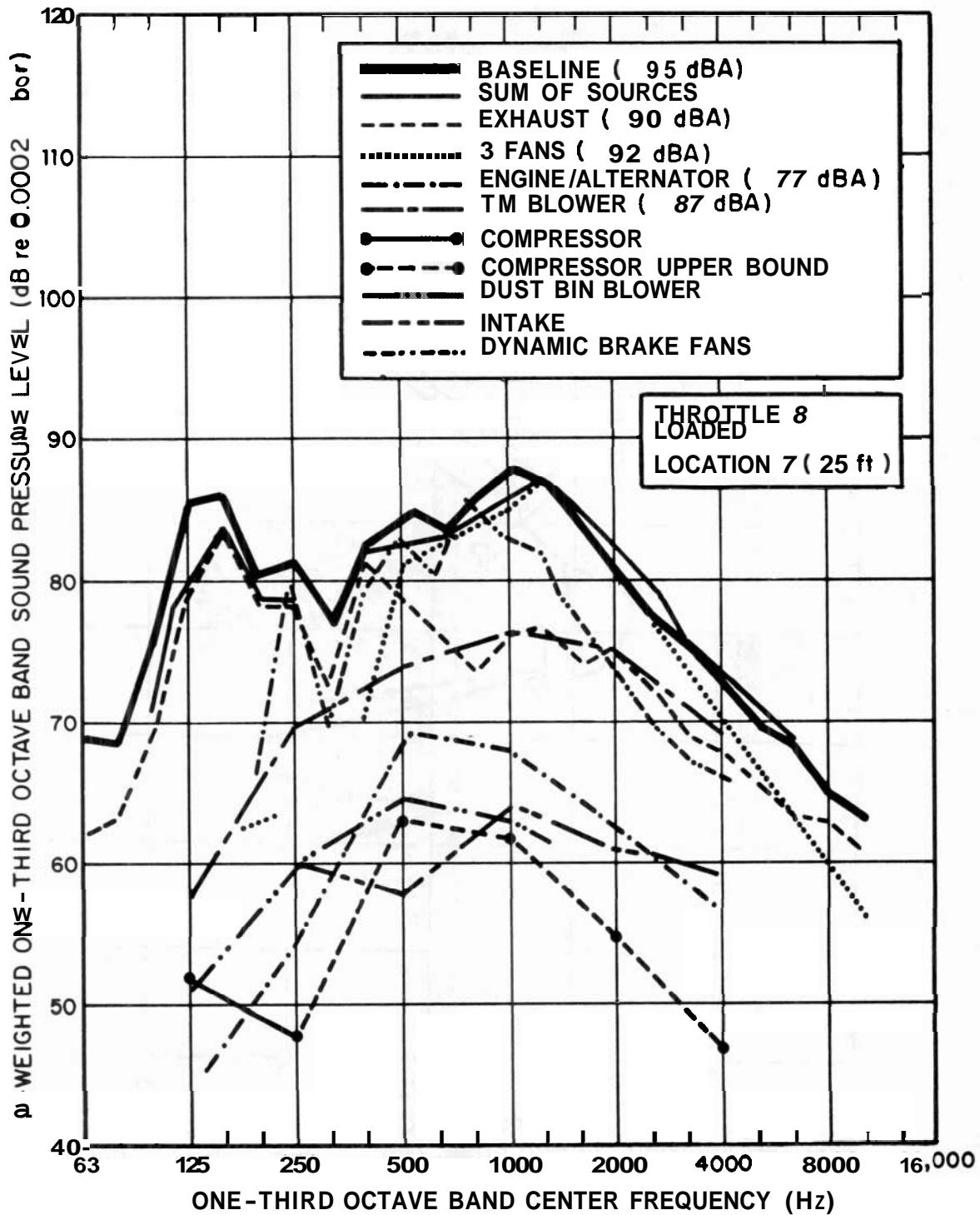

FIG. B.20. SOURCE SPECTRA, THROTTLE 8, FULL LOAD, MICROPHONE LOCATION 7.

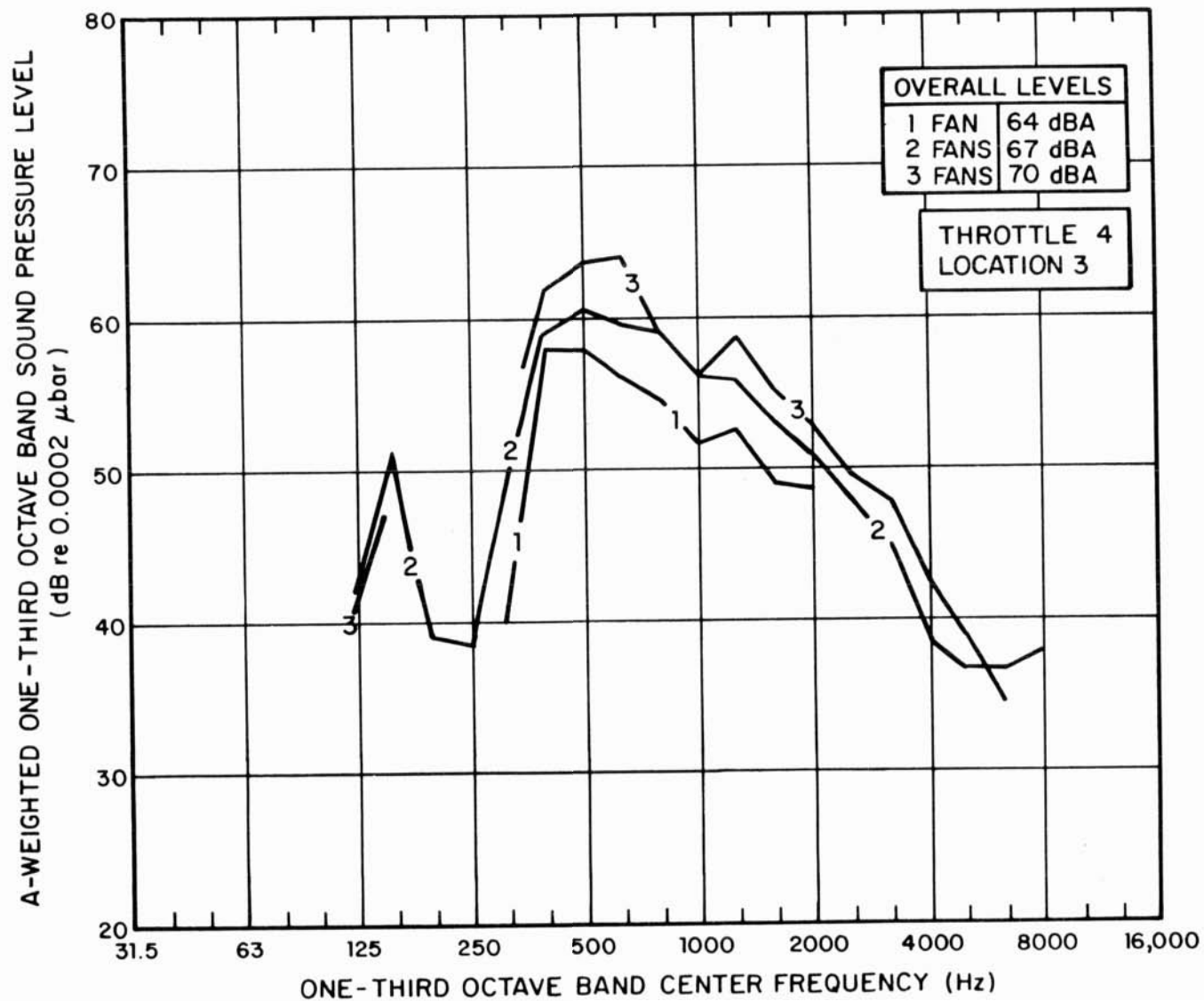

FIG. B.21. FAN SOURCE SPECTRA, THROTTLE 4, MICROPHONE LOCATION 3. THE NUMBERS REFER TO THE NUMBER OF FANS OPERATING.

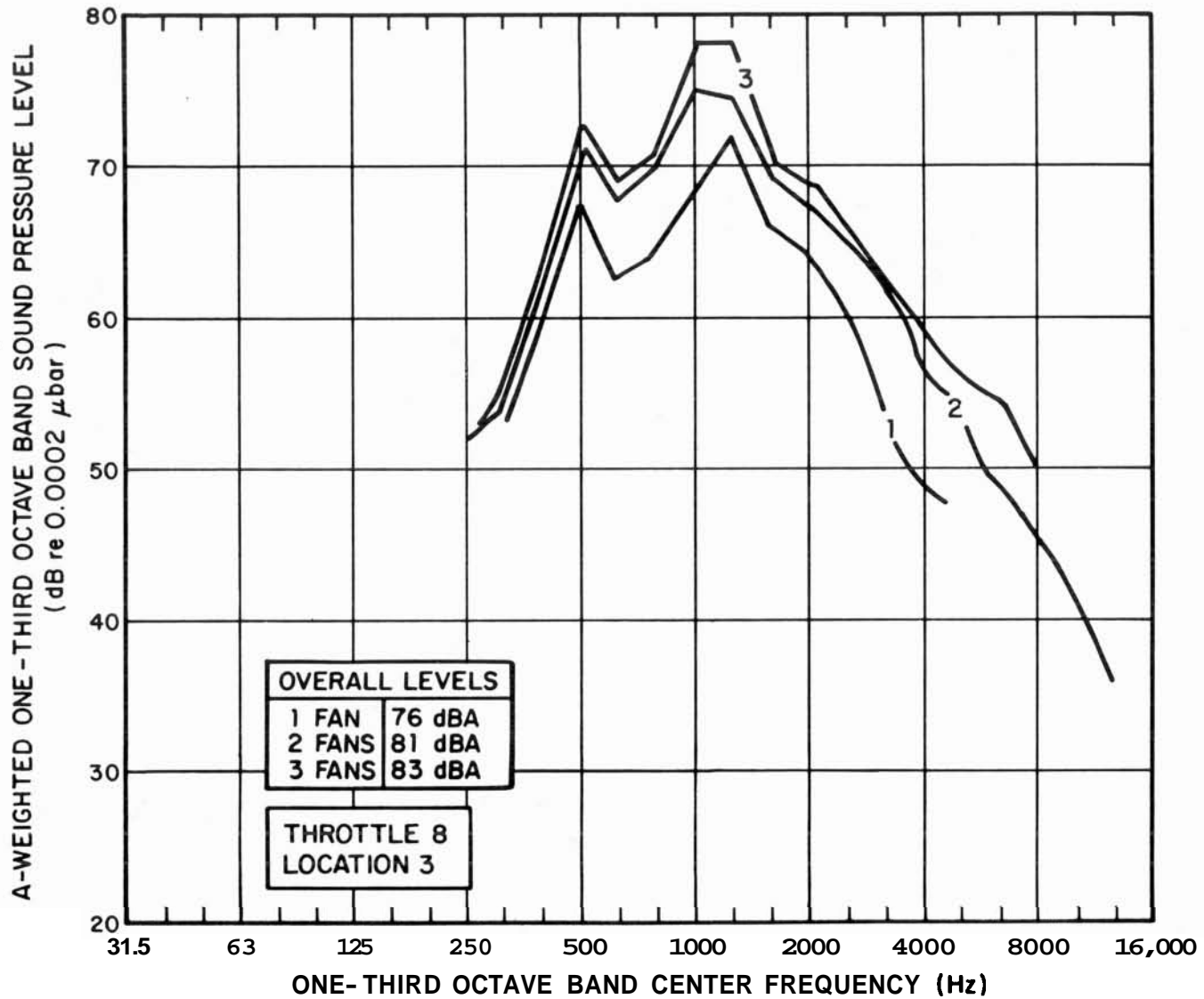

FIG. B.22. FAN SOURCE SPECTRA, THROTTLE 8, MICROPHONE LOCATION 3. THE NUMBERS REFER TO THE NUMBER OF FANS OPERATING.



## APPENDIX C: AIRBORNE TRANSFER FUNCTIONS

During the locomotive testing, noise produced by a source of interest was frequently so low that only by taking measurements quite close to it could one distinguish that source from all the others. Analytical means for extrapolating those close-by measurements to farfield locations are, except in the simplest cases, too inexact. Therefore, we measured transfer functions to relate noise at various locations around and inside the locomotive to the noise at the seven farfield locations described in Sec. 3.

A loudspeaker placed at a particular location of interest was driven with white noise filtered in octave bands. The noise at one or more specified locations near the loudspeaker and at the seven locations of interest around the locomotive was measured in corresponding octave bands. The ratio of the farfield noise levels to the nearfield levels in each octave band yielded a transfer function relating nearfield to farfield levels as a function of frequency.

In this report, we were particularly concerned with the airborne transfer functions for the air compartment, compressor, engine/alternator, and the dust bin blower. The procedure for obtaining each of these is discussed below.

### *Air Compartment*

A speaker box containing four 6-in. speakers oriented in various directions was installed on the floor of the air compartment. One microphone was placed in the air compartment, approximately centered between the engine intake and traction motor blower inlet. The resulting transfer function is shown in Fig. C.1. These transfer functions were used to estimate traction motor blowers and engine intake source spectra.

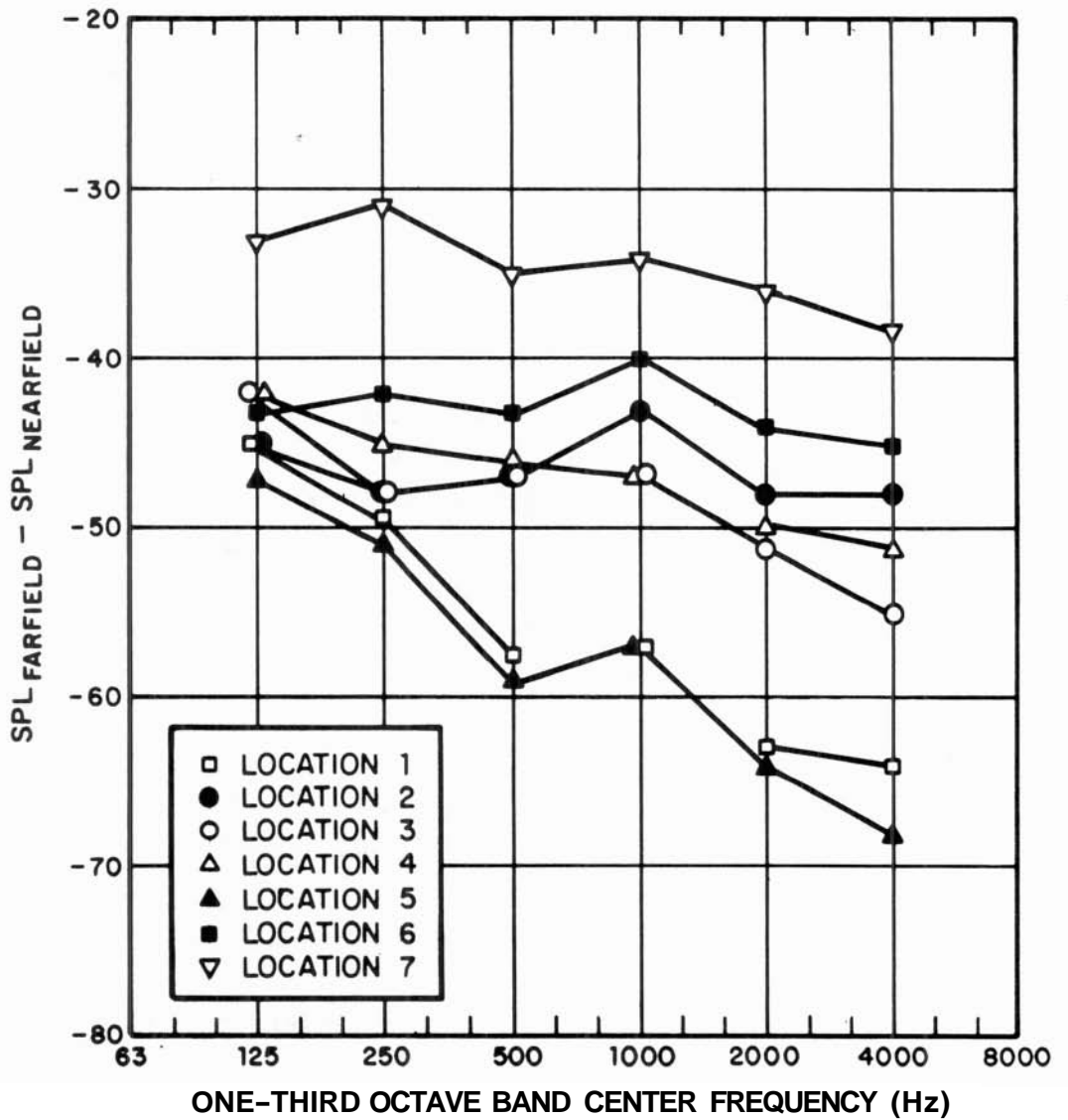

FIG. C.1. AIR COMPARTMENT AIRBORNE PATH TRANSFER FUNCTION.

### *Compressor*

The same speaker box used in the air compartment was placed on the floor of the engine compartment just aft of the compressor. One microphone was mounted directly above the compressor to obtain the sound pressure level under the hood. The resulting transfer functions are shown in Fig. C.2 for each farfield microphone. \*

### *Engine/Alternator*

The same speaker system was placed on top of the valve covers on the engine, approximately midway along its length and on the right side of the locomotive. Three microphones were located under the hood around the engine. The average of these three microphones was used to estimate the underhood noise from the speakers. The resulting transfer functions for the seven farfield locations are shown in Fig. C.3.

### *Dust Bin Blower*

The speaker system was placed on top of the dust bin blower outlet on top of the hood. Only those speakers that faced upward were activated. Two microphones were located 1 ft from the speakers in the plane of the speaker grill. The average of these two microphones was used to estimate the nearfield levels. The resulting transfer functions for the seven farfield microphones are shown in Fig. C.4.

The four sets of transfer functions are consistent. The compressor and engine transfer functions are very similar.

---

\*Noise data under the hood at 125 Hz were improperly taken; as a result, we have no transfer function values at that frequency.

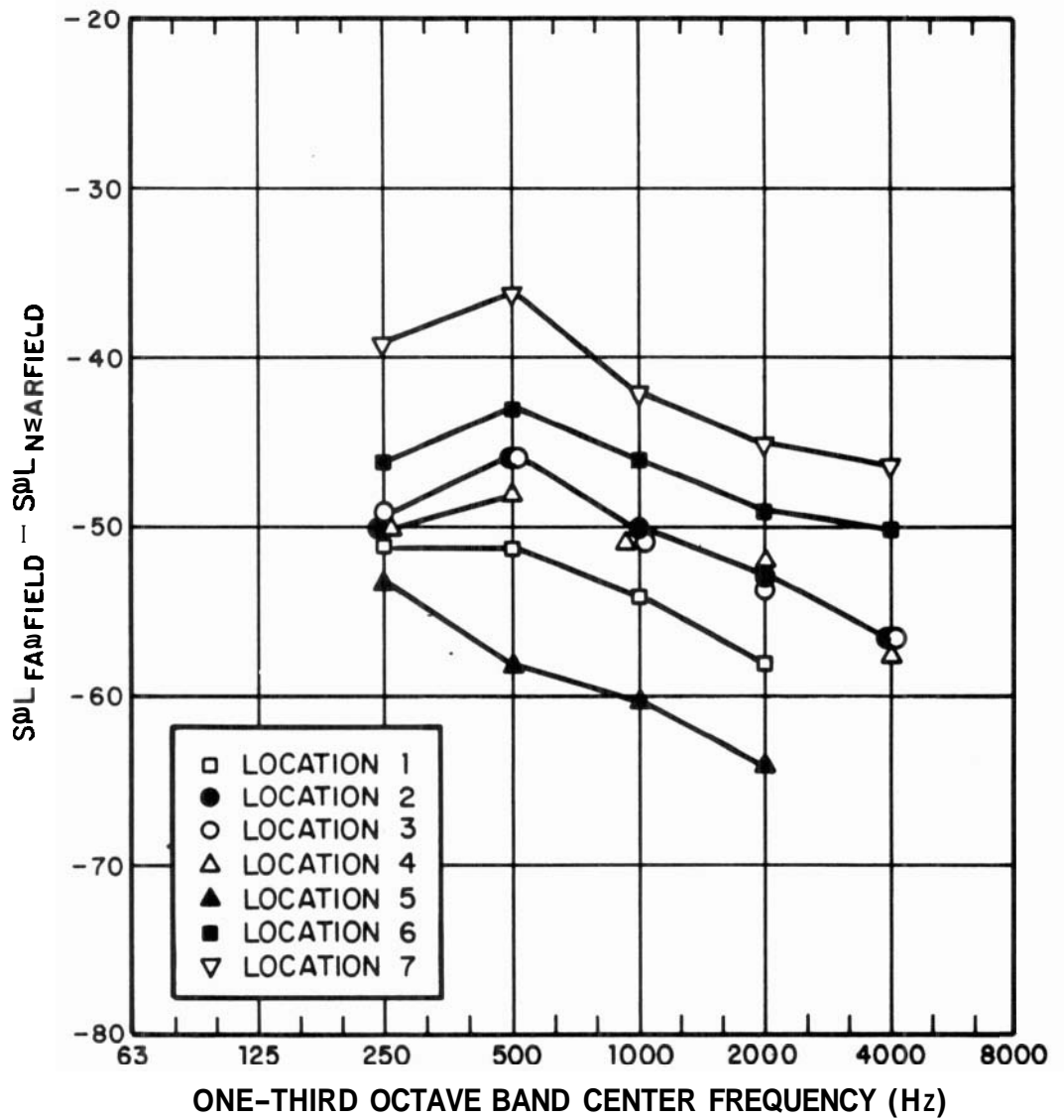

FIG. C.2. COMPRESSOR AIRBORNE PATH TRANSFER FUNCTIONS.

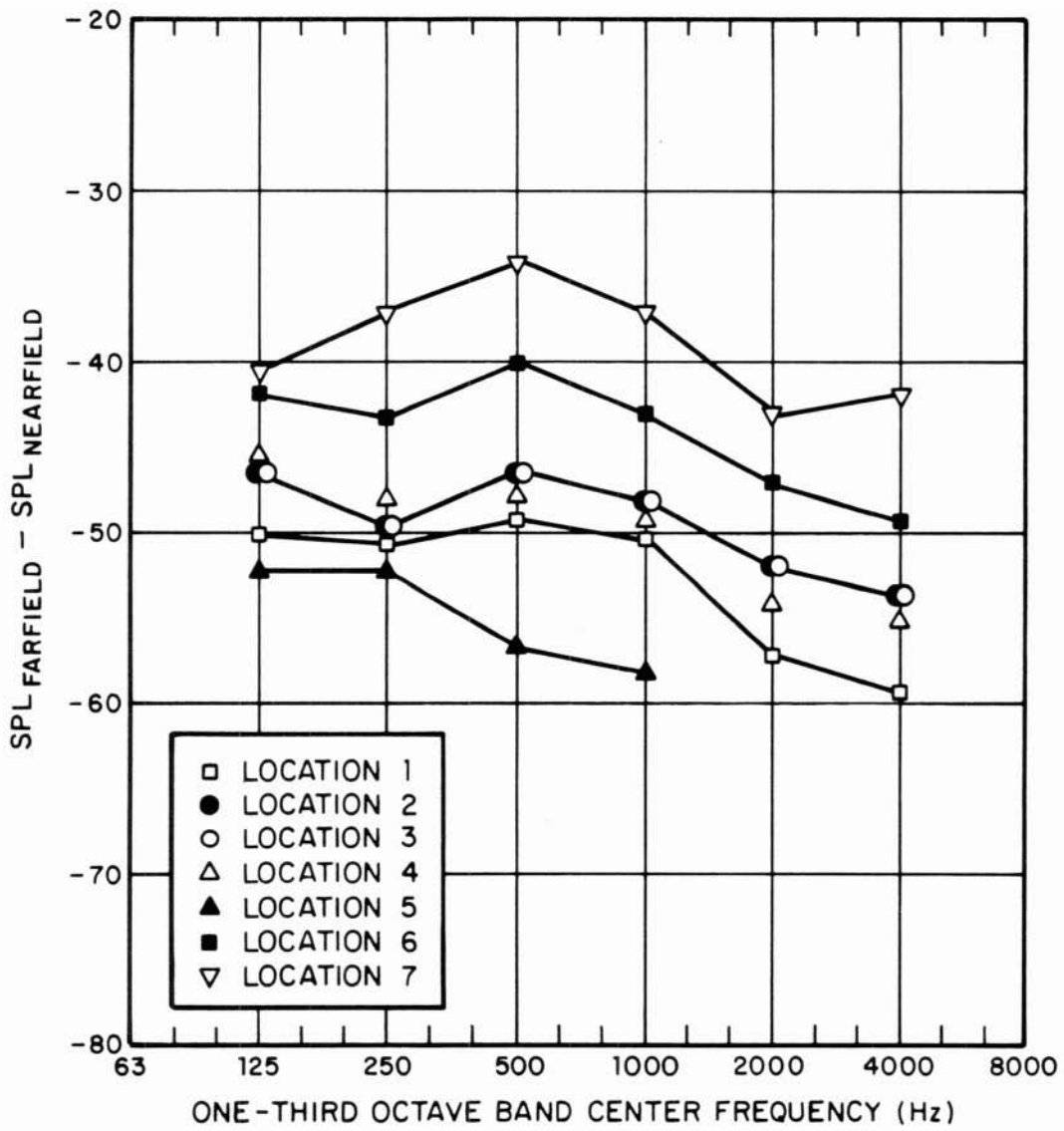

FIG. C.3. ENGINE/ALTERNATOR AIRBORNE PATH TRANSFER FUNCTION.

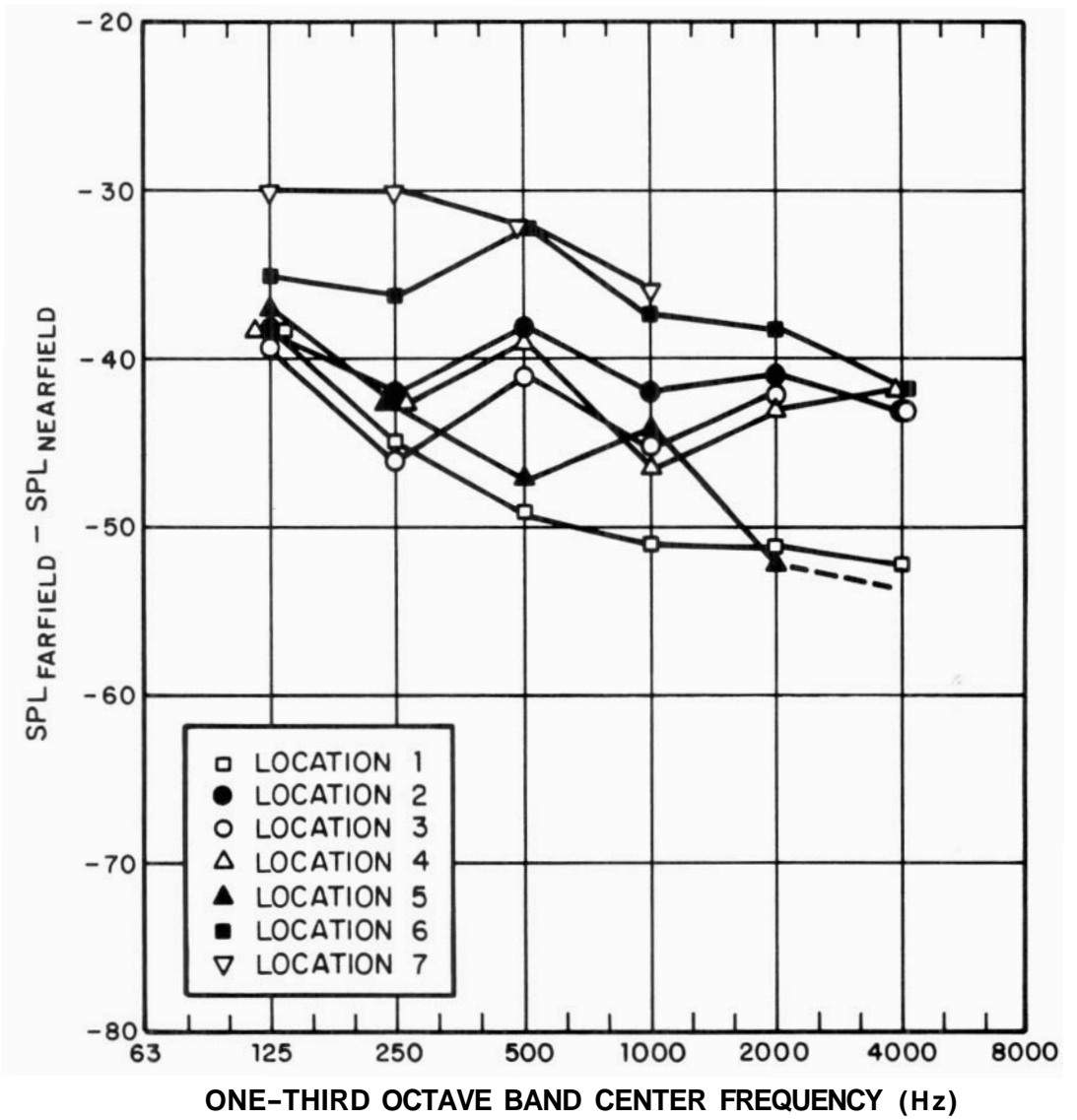

FIG. C.4. DUST BIN BLOWER TRANSFER FUNCTION.

Locations 6 and 7 have somewhat higher transfer functions from the engine since these locations are closer to the engine than to the compressor. The air compartment transfer functions are generally higher than the engine transfer functions, probably because of the large inlet opening into the air compartment. The opposite is true at location 1 in the rear of the locomotive, where the entire length of the locomotive isolates the air compartment from an observer. It is encouraging to note that the dust bin blower transfer functions predict that the noise 100 ft from the blower will be approximately 40 dB below that measured 1 ft from the blower (i.e., locations 2, 3, and 4), a prediction that agrees with simple spherical spreading laws.

## APPENDIX D: STRUCTUREBORNE TRANSFER FUNCTIONS

Locomotive noise can travel by two paths: airborne and structureborne. Transmission by a structureborne path occurs when a component (such as the engine) vibrates and sets the structure of the locomotive vibrating, thus causing the component to radiate sound. On the SD40-2 locomotive, we identified the engine, the main alternator, and the radiator cooling fans as possible structureborne sources. In this appendix, we describe the measurements performed to determine transfer functions relating the vibration at the mounting points of each of these components to the resulting noise at the locations of interest around the locomotive.

In order to estimate the noise generated by vibration at the mounting points of the above components we struck the mounting points\* with a lead hammer many times successively, while simultaneously measuring the vibration at the mounting point and the resulting sound at the seven locations of interest around the locomotive. Even hammering on the mounts did not produce enough noise to overcome the background noise at all locations. As a result, we show only results for locations 3 and 7 at 100 ft and 25 ft from the locomotive, respectively.

Measurements of the vibration at the engine and main alternator mount have shown horizontal and vertical vibration spectra to be very nearly equal at acoustic frequencies. At the compressor and cooling fan mounts, vertical vibration dominates over horizontal.

---

\*To excite the fans, we struck the locomotive hood on the fan centerline at two locations between the forward and middle fans and between the middle and aft fans. We measured the vibration at these two locations simultaneously. Comparable vibration spectra were obtained at the two locations when either of them was struck.



Space restrictions under the hood prevented us from striking the engine and main alternator mounts in the horizontal directions. As a result, all structureborne transfer functions are for vertical excitation only. Since the engine and main alternator mounts vibrate significantly in the horizontal direction as well as the vertical direction, we are necessarily underestimating the engine/main alternator structureborne contributions.

The structureborne transfer functions are shown in Figs. D.1 and D.2 for microphone locations 3 and 7, respectively. Since location 3 is three times as far away from the locomotive as location 7, one would expect location 7 to be on the order of 10 dB higher than location 3 for localized sources. This is very nearly the case, as the two figures show.

Estimates of the structureborne noise at locations 3 and 7 are shown in Figs. D.1 to D.8. These estimates were obtained by adding transfer function levels to measured vibration levels. The engine is seen to be the dominant structureborne noise source.

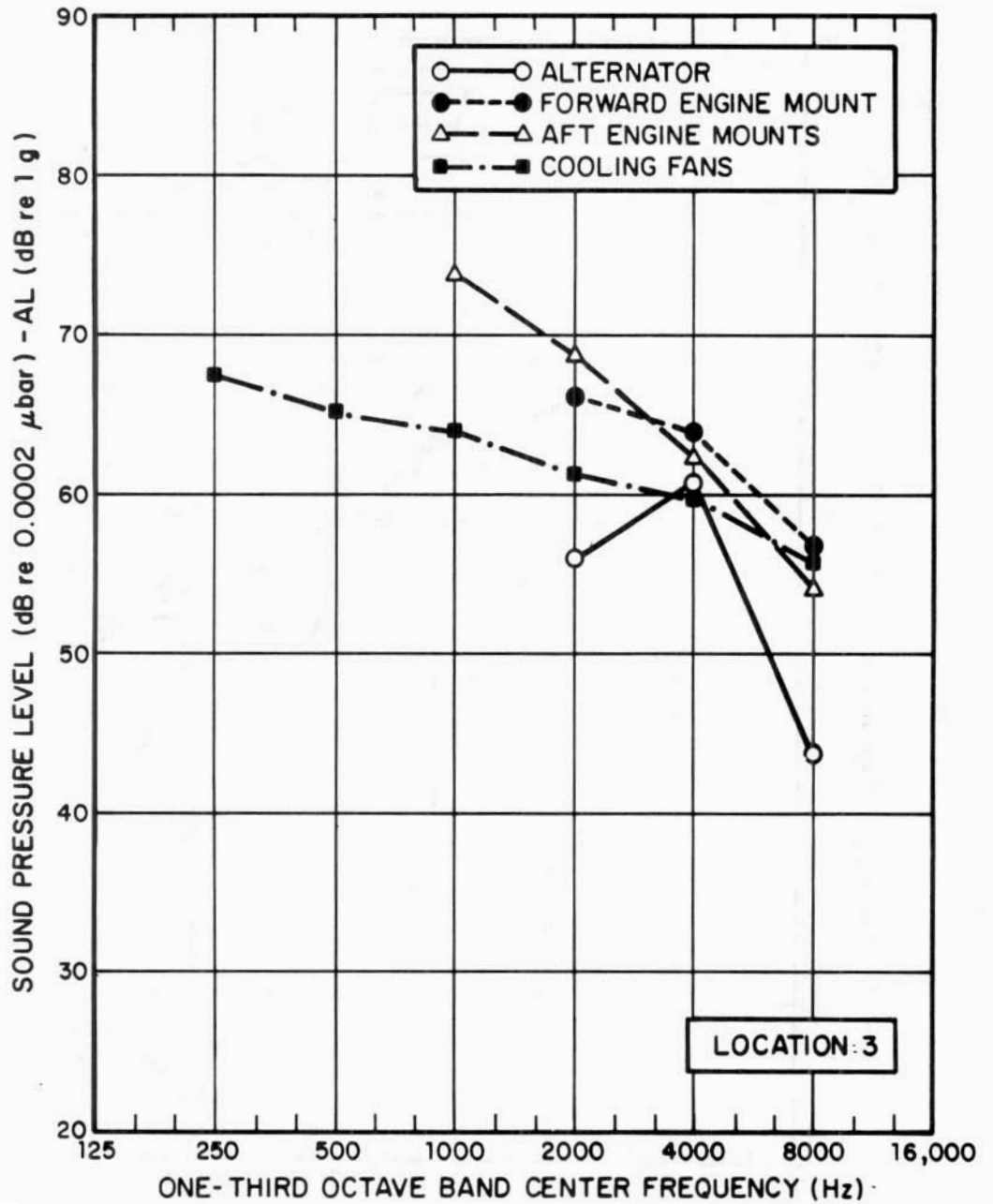

FIG. D.1. STRUCTUREBORNE TRANSFER FUNCTIONS FOR MICROPHONE LOCATION 3.

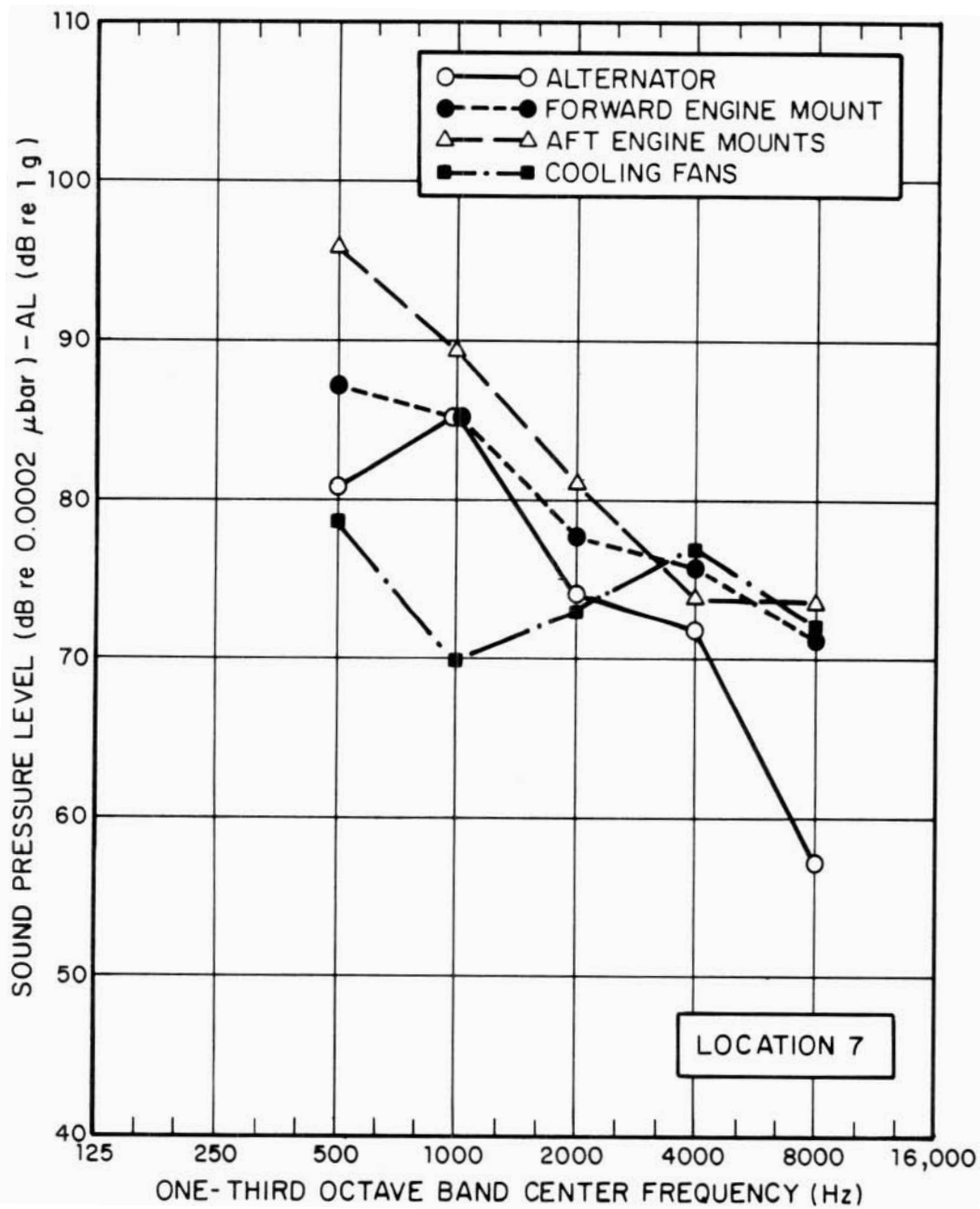

FIG. D.2. STRUCTUREBORNE TRANSFER FUNCTIONS FOR LOCATION 7.

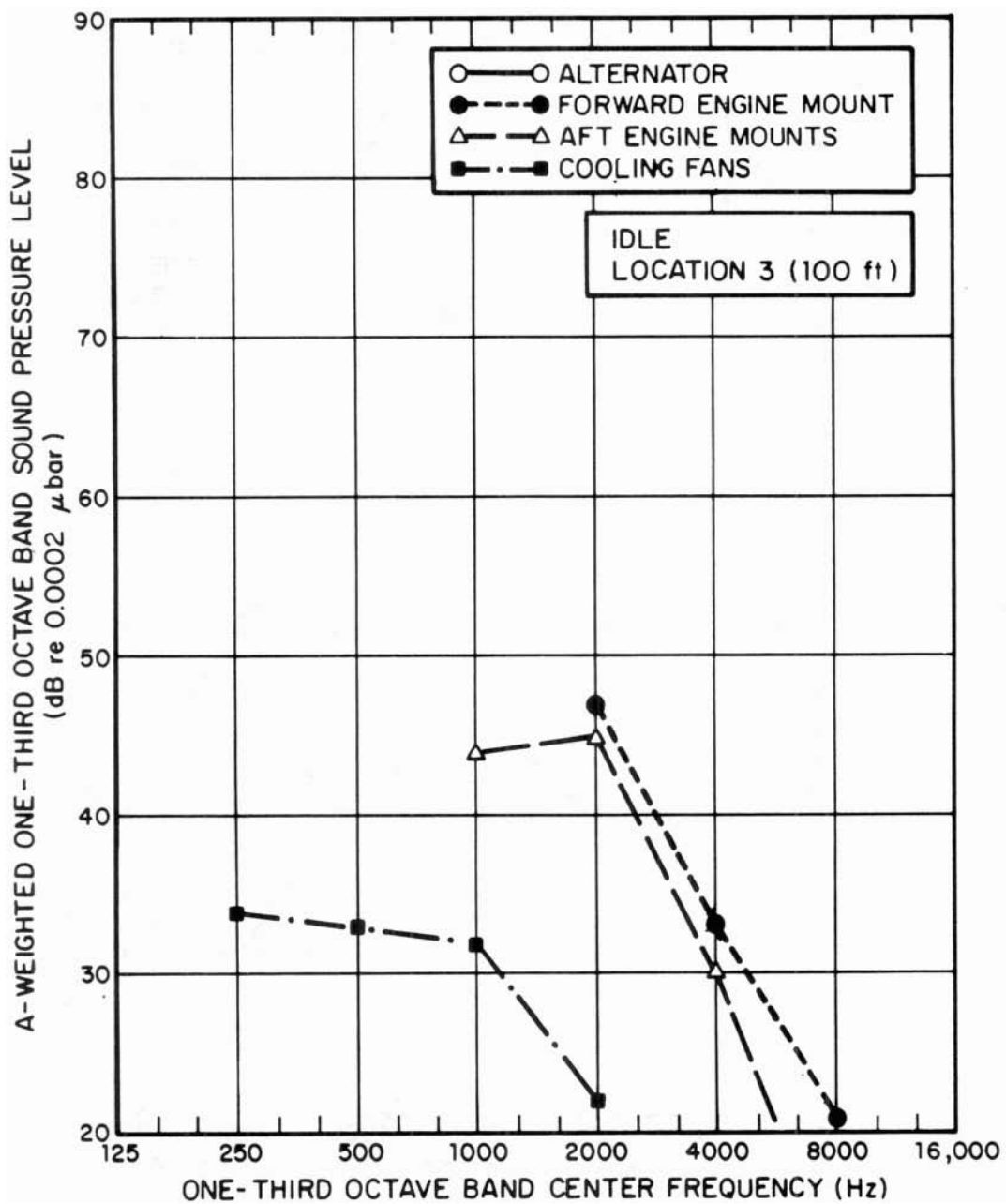

FIG. D.3. STRUCTUREBORNE NOISE AT IDLE, LOCATION 3.

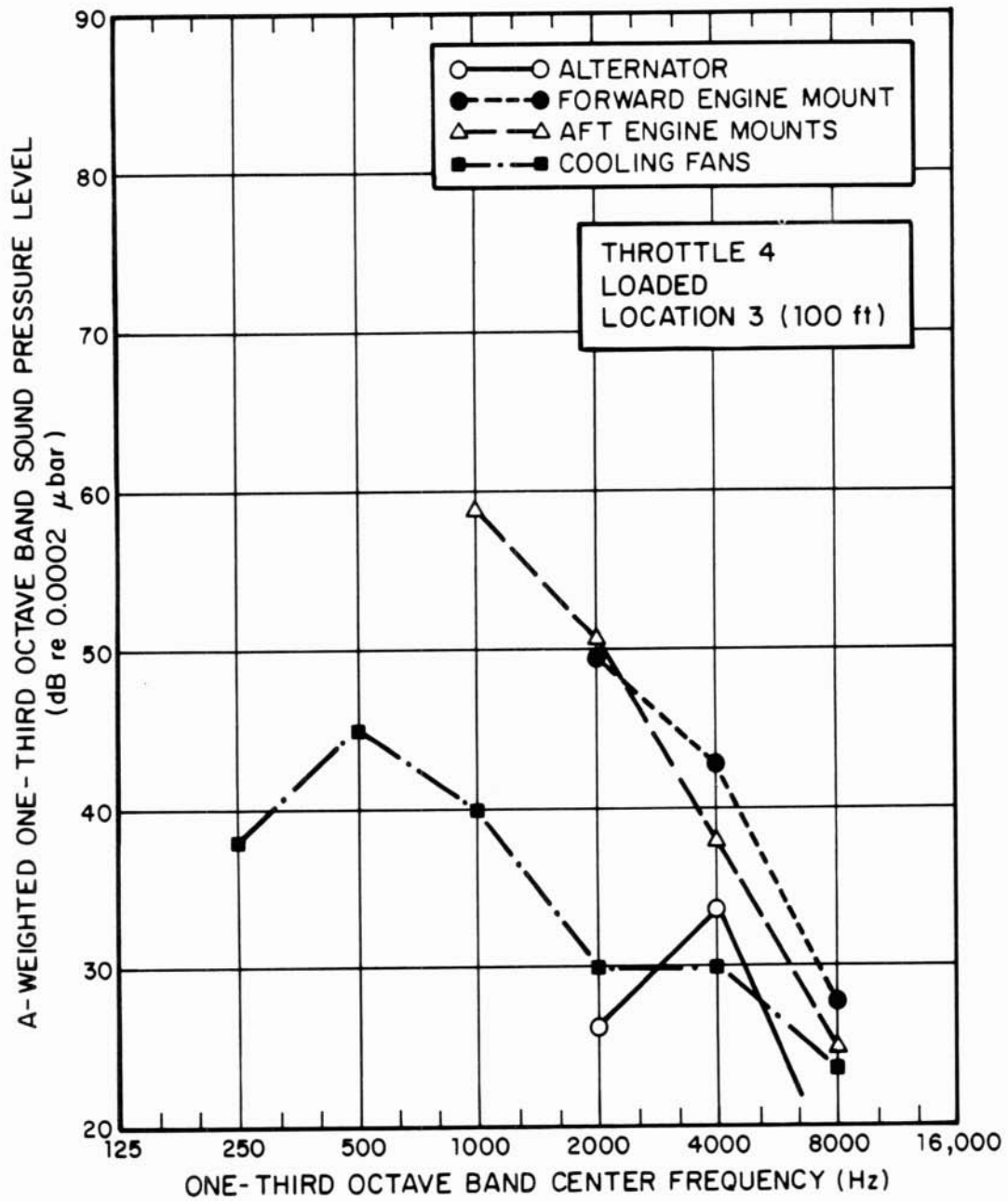

FIG. D.4. STRUCTUREBORNE NOISE AT THROTTLE 4, FULL LOAD, LOCATION 3.

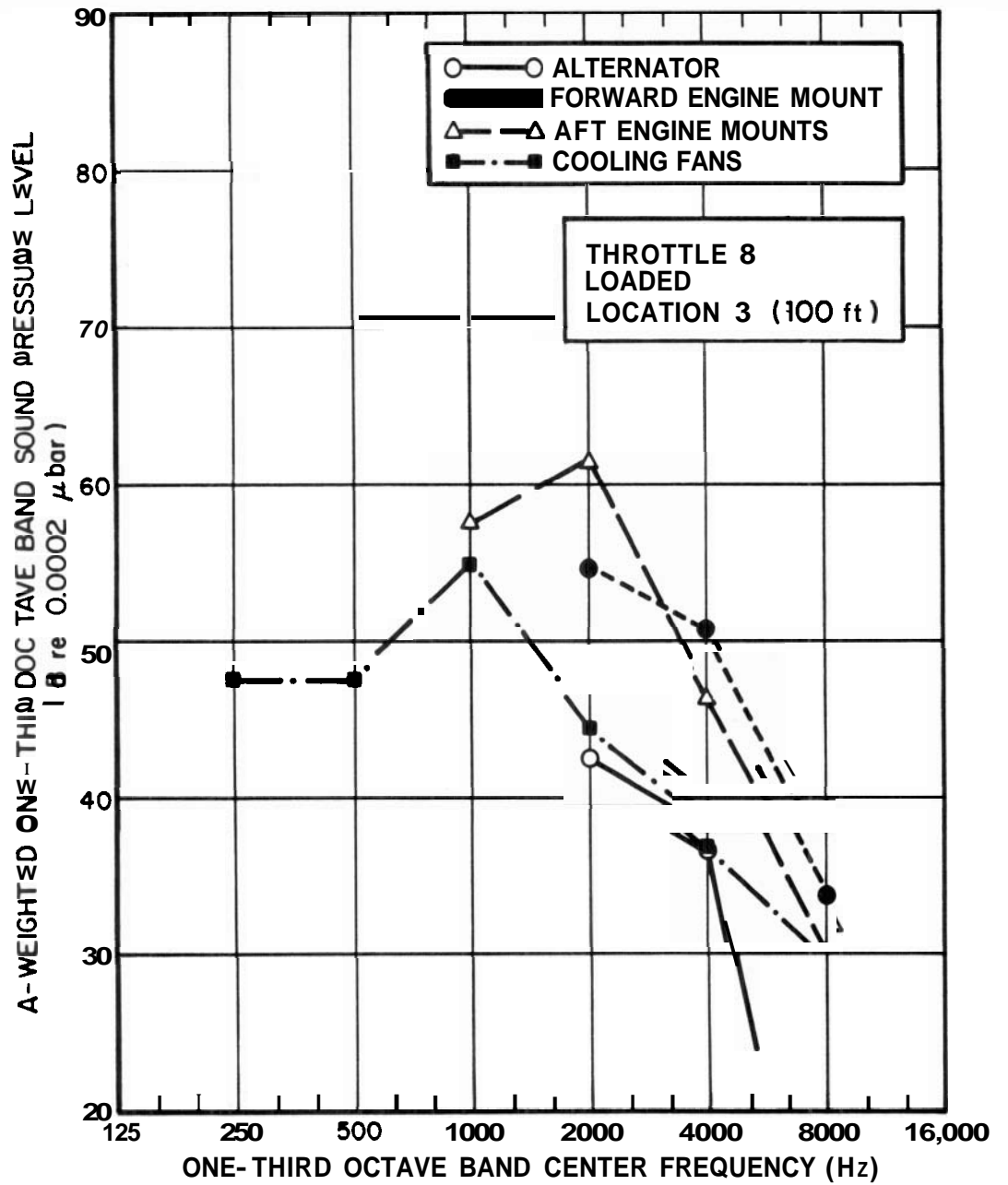

FIG. D.5. STRUCTUREBORNE NOISE AT THROTTLE 8, FULL LOAD, LOCATION 3.

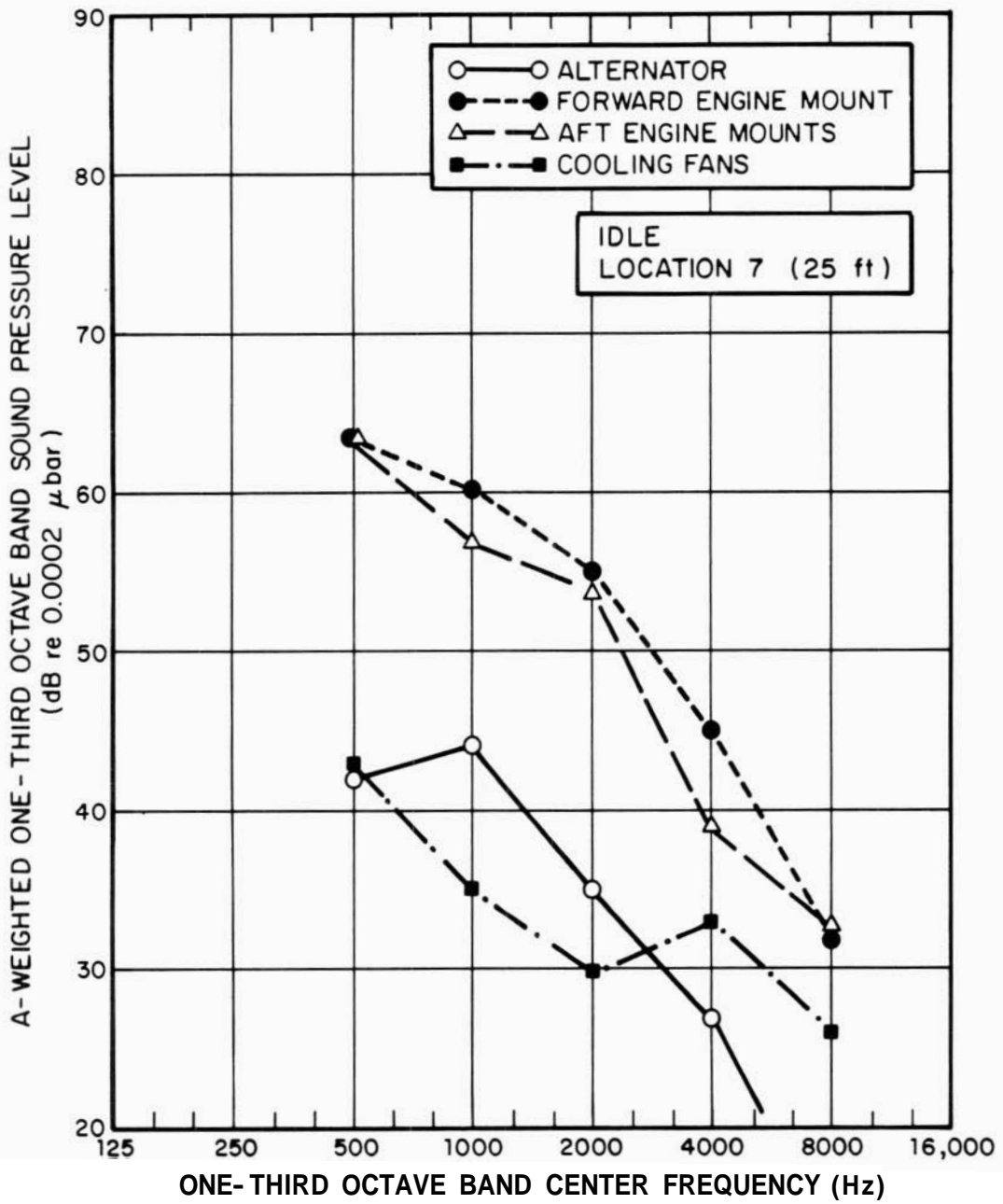

FIG. D.6. STRUCTUREBORNE NOISE AT IDLE, LOCATION 7.

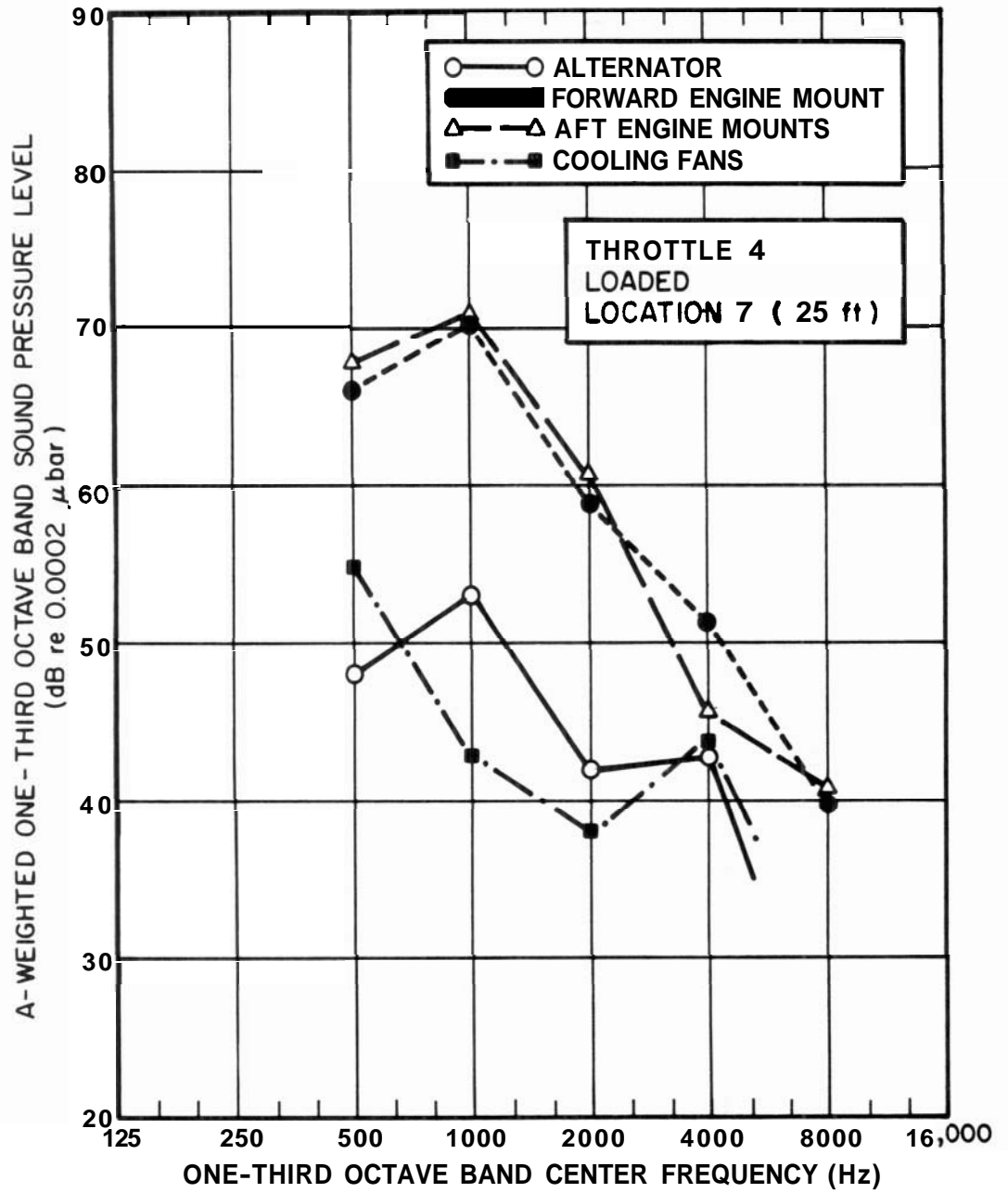

FIG. D.7. STRUCTUREBORNE NOISE AT THROTTLE 4, FULL LOAD, LOCATION 7.



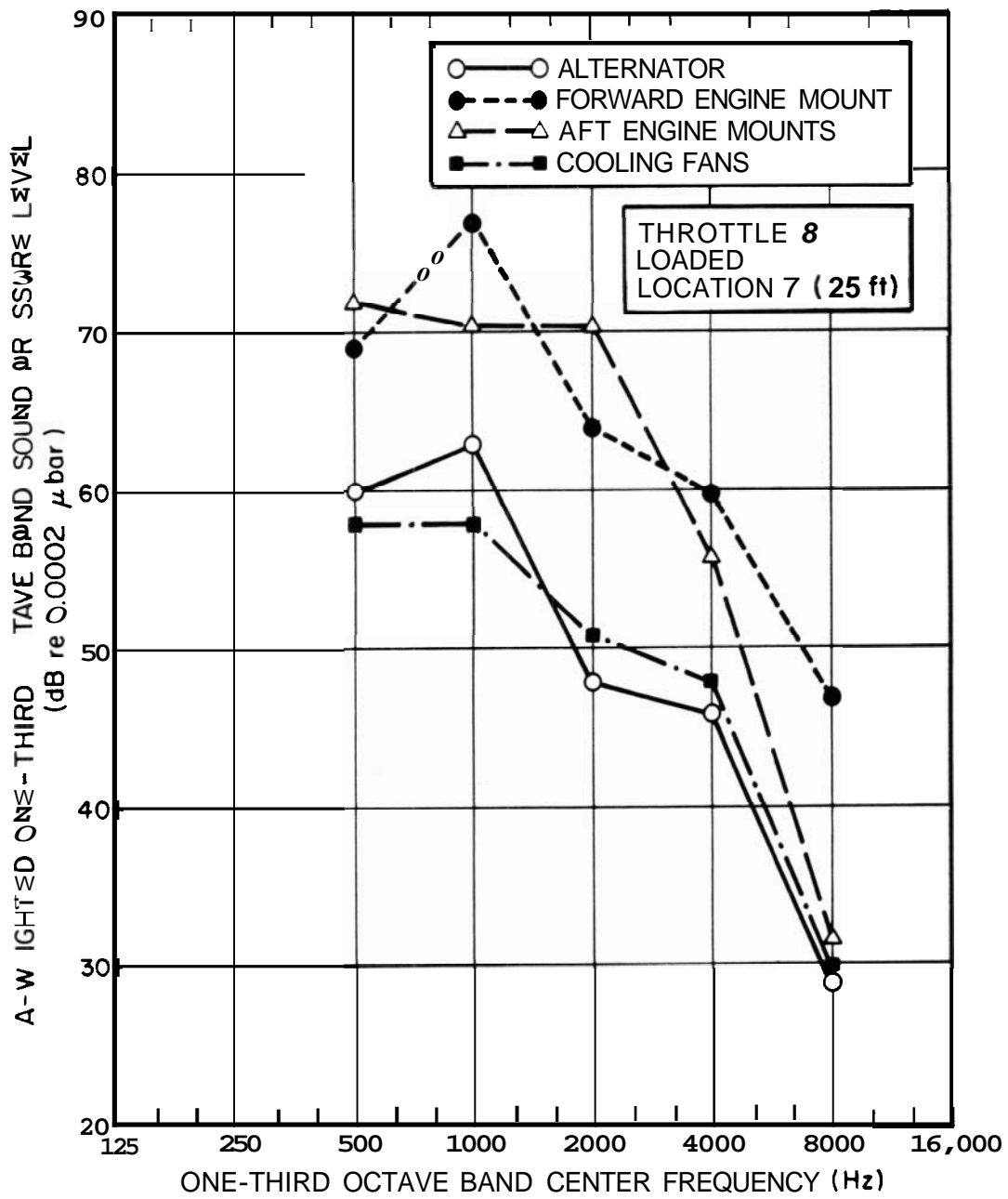

FIG. 0.8. STRUCTUREBORNE NOISE AT THROTTLE 8, FULL LOAD, LOCATION 7.

## APPENDIX E: LOAD CELL NOISE

A General Electric air cooled resistor bank load cell was used to dissipate the power from the locomotive in the stationary tests. The cell has a large squirrel cage blower used to cool the resistor grids that increases in speed as the load dissipated increases. This blower generates considerable noise and to minimize interference with the measurements a 3/4-in. plywood barrier was constructed around the load cell as described in the text. Despite the presence of the barrier the load cell could be heard at several microphone locations with the locomotive running in the fully quieted configuration. In order to quantify the contribution of load cell noise to the noise measurements at each microphone location, measurements of load cell noise near the load cell were extrapolated to the microphone locations around the locomotive using a transfer function approach.

Figure E.1 shows estimates of the noise from the load cell 6 ft in front of the barrier based on noise measurements at that location\* with the locomotive in the fully quieted configuration and running loaded at throttles 4 and 8. The spectra show strong peaks at 630 Hz and 1250 Hz at throttle 4 and at 1000 Hz and 2000 Hz at throttle 8, which is consistent with the tonal nature of the noise from the load cell.

These spectra are extrapolated to the microphone locations of interest around the locomotive using the transfer functions of Fig. E.2. These were obtained by placing a 6-speaker source excited with octave band random noise on the flat car near the load cell blower inlet prior to erection of the barrier. The

---

\*Measurements were taken at three locations 10 ft apart along a line 6 ft in front of the barriers, the center microphone being directly in front of the barrier.

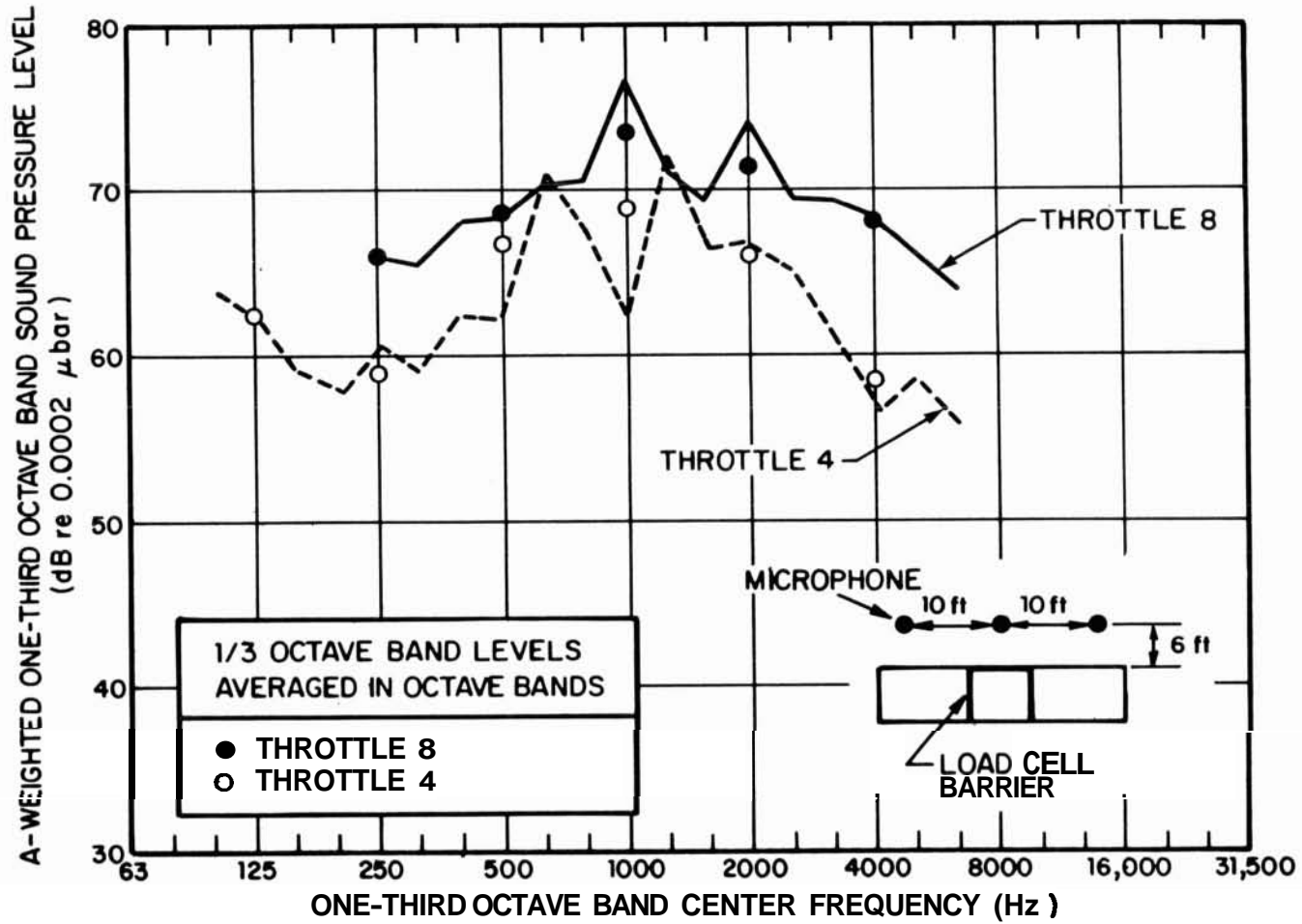

FIG. E.1. LOAD CELL NOISE 6 FT FROM THE BARRIER.

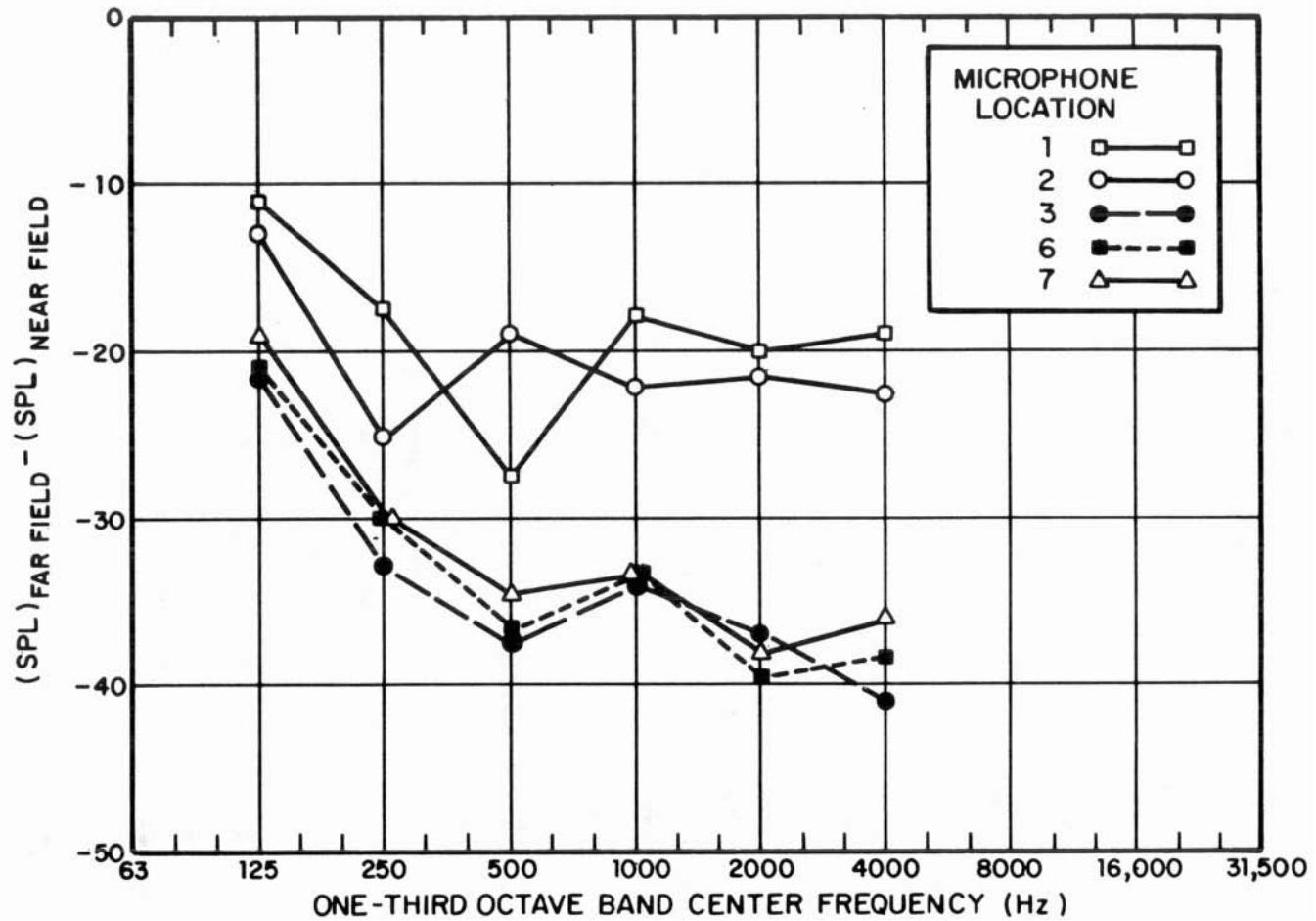

FIG. E.2. LOAD CELL AIRBORNE TRANSFER FUNCTIONS LOCATION NUMBERS REFER TO THE MICROPHONE LOCATIONS IN FIG. 3.8.

noise was then measured in octave bands at the microphone locations of interest (see Fig. 3.8) and 6 ft in front of the planned barrier location. The differences between the sound pressure level at each farfield microphone location and the nearfield location gave the transfer functions in Fig. E.2. No transfer functions are shown for locations 4 and 5. These locations were shielded from the speaker by load cell panels and gave values for the transfer functions that resulted in load cell noise estimates at those locations that were too low to account for the fact that the load cell could be heard at locations 4 and 5 with the locomotive in the fully quieted condition.

In order to use the data in Fig. E.2, the near field load cell spectra in Fig. E.1 have been averaged in those octave bands for which transfer function data is available. For example, the levels at 1000 Hz in Fig. E.1 (open and closed circles), use the result of averaging the 1/3 octave band levels at 800, 1000 and 1250 Hz.

Figures E.3 and E.4 show the estimated A-weighted 1/3 octave band sound levels due to the load cell at the microphone locations of interest.

Consistent with the observation that the load cell could not be heard at locations 3, 6 and 7, the estimated load cell noise levels at those locations are much lower than the locomotive noise levels measured there with the locomotive in the fully quieted condition. Consistent with the observation that the load cell *could* be heard at locations 1 and 2 the estimated load cell spectra levels there are comparable to the quieted baseline spectral levels at the higher frequencies.

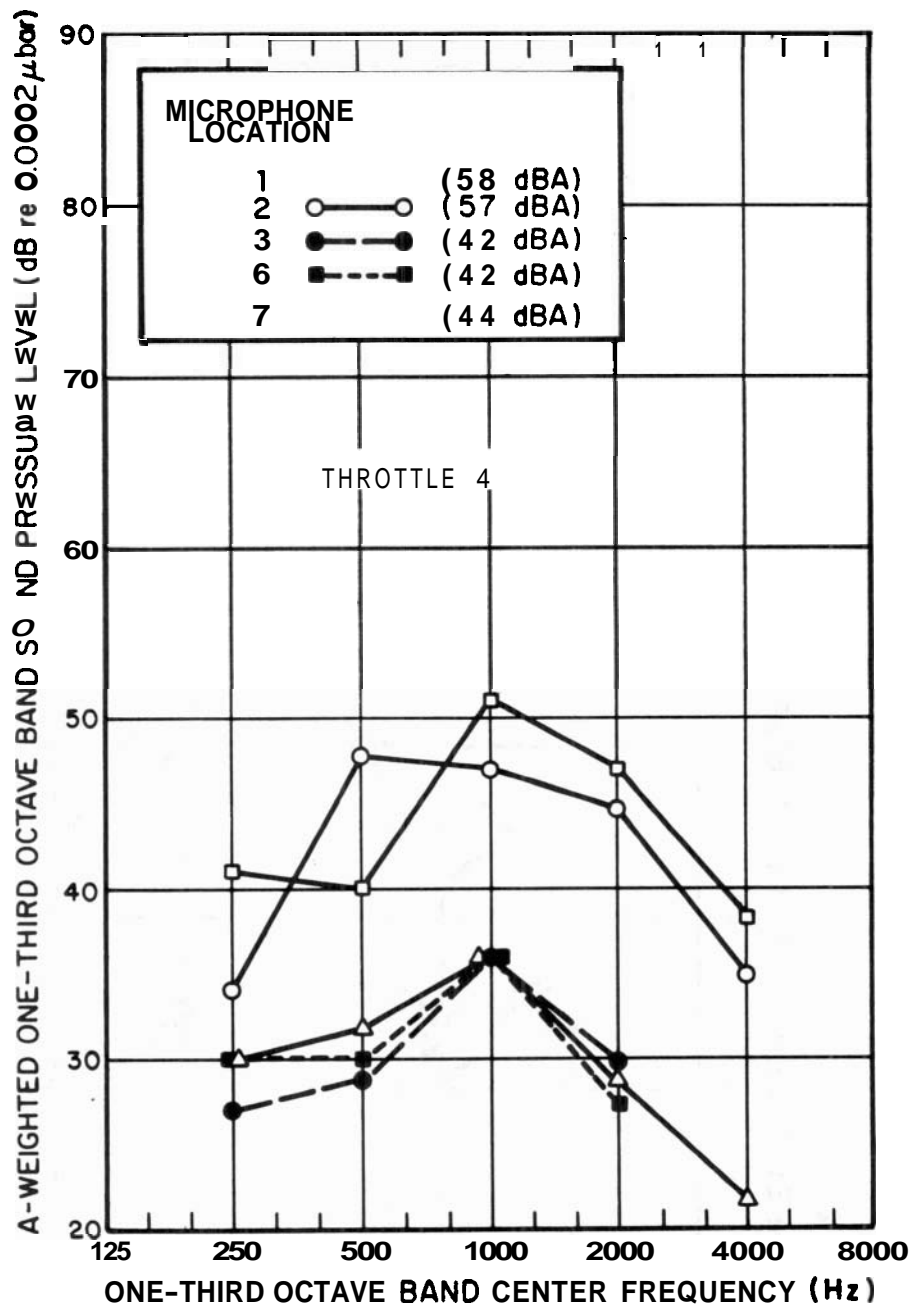

FIG E.3. LOAD CELL NOISE AT THROTTLE 4.

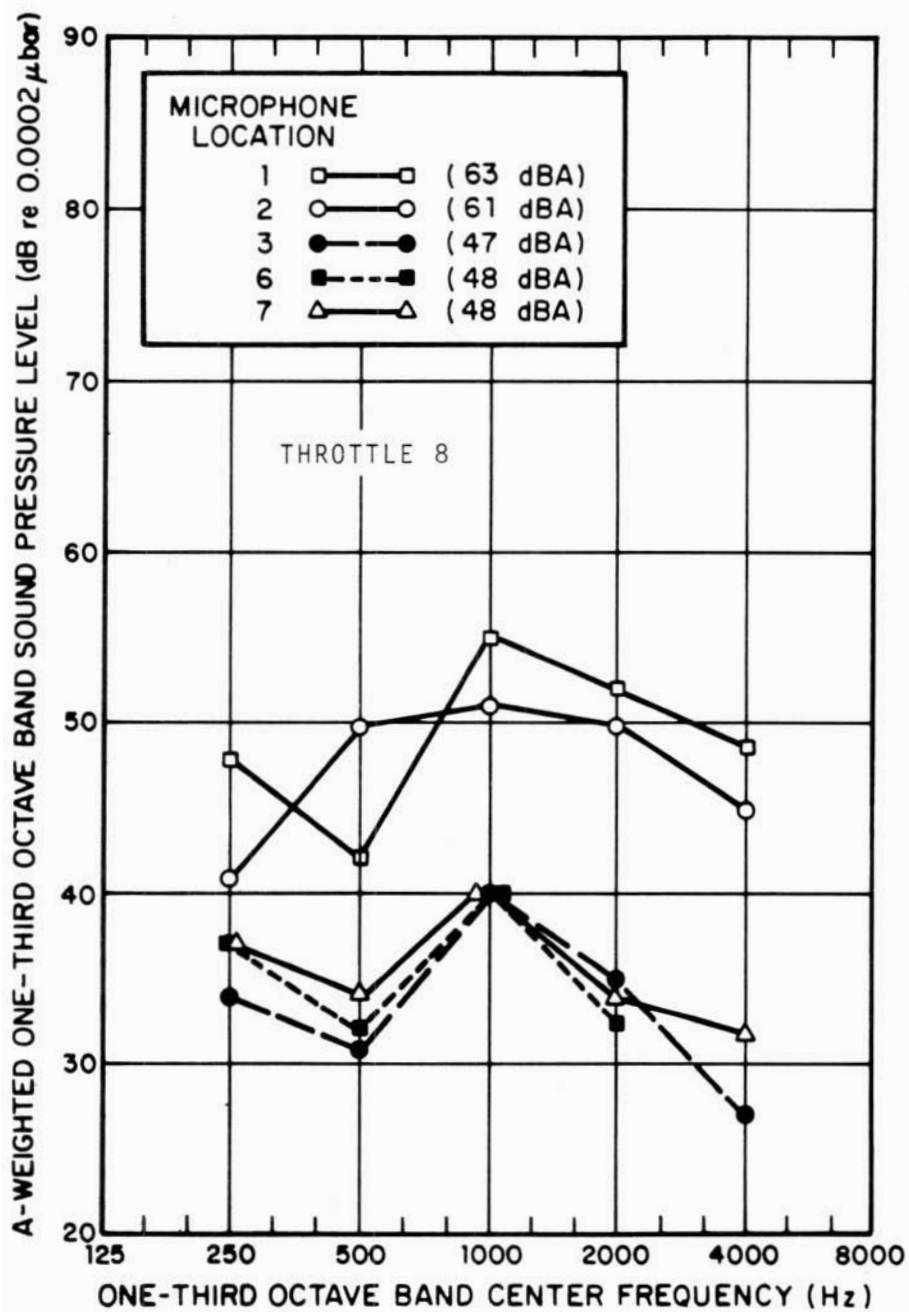

FIG. E.4. LOAD CELL NOISE AT THROTTLE 8.

APPENDIX F: REPORT OF INVENTIONS

After a diligent review of the work performed under this contract, we have determined that to date **no innovation**, discovery, improvement, or invention has been made.



