

# **Track and Rail and Infrastructure Integrity Compliance Manual**

## **Volume II Track Safety Standards Chapter 1 Track Safety Standards Classes 1 Through 5**

**January 2017**

**Office of Railroad Safety**



U.S. Department of Transportation  
**Federal Railroad Administration**

## Table of Contents

<b>CHAPTER 1 .....</b>	<b>5</b>
TRACK SAFETY STANDARDS CLASSES 1 THROUGH 5.....	5
Introduction.....	5
SUBPART A – GENERAL .....	5
§ 213.1 Scope of part .....	5
§ 213.3 Application .....	6
§ 213.4 Excepted track .....	8
§ 213.5 Responsibility for compliance.....	12
§ 213.7 Designation of qualified persons to supervise certain renewals and inspect track ..	14
§ 213.9 Classes of track: operating speed limits .....	17
§ 213.11 Restoration or renewal of track under traffic conditions .....	23
§ 213.13 Measuring track not under load.....	24
§213.14 Application of requirements to curved track.....	24
§ 213.15 Penalties.....	25
§ 213.17 Waivers.....	25
§213.19 Information collection .....	26
SUBPART B – ROADBED .....	26
§ 213.31 Scope .....	26
§ 213.33 Drainage .....	26
§ 213.37 Vegetation .....	27
SUBPART C – TRACK GEOMETRY .....	29
§ 213.51 Scope .....	29
§ 213.53 Gage.....	29
§ 213.55 Track alinement .....	30
§ 213.57 Curves; elevation and speed limitations .....	36
§ 213.59 Elevation of curved track; (runoff) .....	45
§ 213.63 Track Surface .....	46
§ 213.65 Combined track alinement and surface deviations .....	52
SUBPART D – TRACK STRUCTURE .....	53
§ 213.101 Scope .....	53
§ 213.103 Ballast; general .....	53
§ 213.109 Crossties.....	54
§ 213.110 Gage Restraint Measurement Systems.....	62
§ 213.113 Defective rails .....	71
§ 213.115 Rail end mismatch .....	83
§ 213.118 Continuous welded rail (CWR); plan review and approval.....	84
§ 213.119 Continuous welded rail (CWR); plan contents .....	85
§ 213.121 Rail joints .....	101
§ 213.122 Torch cut rail .....	106
§ 213.123 Tie plates .....	107
§ 213.127 Rail fastening systems .....	107
§ 213.133 Turnouts and track crossing generally.....	110
§ 213.135 Switches .....	111
§ 213.137 Frogs .....	117
§ 213.139 Spring rail frogs.....	124
§ 213.141 Self-guarded frogs .....	127
§ 213.143 Frog guard rails and guard faces; gage.....	128
SUBPART E – TRACK APPLIANCES AND TRACK - RELATED DEVICES.....	132

§ 213.201 Scope .....	132
§ 213.205 Derails .....	132
SUBPART F – INSPECTION .....	133
§ 213.231 Scope .....	133
§ 213.233 Track inspections .....	133
§ 213.234 Automated Inspection of Track Constructed with concrete Crossties .....	136
§ 213.235 Inspection of switches, track crossings, and lift rail assemblies or other transition devices on moveable bridges .....	141
§ 213.237 Inspection of rail.....	143
§ 213.238 Qualified operator. ....	149
§ 213.239 Special inspections .....	151
§ 213.241 Inspection records.....	152
<b>APPENDIX .....</b>	<b>157</b>
APPENDIX A – SUPERELEVATION IN INCHES/SPEED MPH.....	157
APPENDIX B – DEFECT CODES .....	159
APPENDIX C – RAIL MILL BRANDING AND KEY DIMENSIONS .....	175
APPENDIX D – USE OF PORTABLE TRACK LOADING FIXTURE (PTLF) IN NON-GRMS TERRITORY.....	185

**January 2017 Release Note (Volume II, Chapter 1):**

Updated from January 2014 release. Changes include:

- Minor spelling and grammatical corrections
- Rule text and guidance for 213.3,
- Rule text and guidance for 213.113, 119, 237, 238 and 241
- Incorporation of PTLF Technical Bulletin in Appendix D

**Text in italic font of this manual is regulatory language, whereas indented paragraphs provide field guidance for FRA inspectors. Indented paragraphs are not to be construed as regulatory language in any manner.**

## CHAPTER 1

### Track Safety Standards Classes 1 Through 5

#### **Introduction**

This chapter provides the necessary information for FRA inspectors to properly apply the Track Safety Standards (TSS) during inspection activities (the term “FRA inspector” also includes State inspectors that are participants in the Federal program). This manual is not to be construed as a modification, alteration, or revision of the published TSS.

Any legal proceeding instituted against a railroad must be based on the regulations found in 49 CFR Part 213. Inspectors should refer to this manual as often as necessary to understand the intent of any particular rules, thereby assuring to the extent practicable the nationally uniform application of these rules as intended by Congress in the Federal Railroad Safety Act of 1970.

Inspectors will not, under any circumstances, adjust, correct, or repair track or appurtenances, nor will they authorize, suggest, or recommend any movements over any track. Full responsibility for these matters rests with the railroad. The inspector will immediately inform the railroad of any track condition not in compliance with the TSS.

This manual is based on the TSS published on October 1, 2015 and the Electronic Code of Federal Regulations (<http://www.ecfr.gov>) which is current as of January, 2017.

Inspectors are encouraged to provide suggestions for enhancement of future editions of this manual.

Appendix B contains the defect codes for each subsection of the regulation. Defect codes are important analytical tools for FRA’s data collection. If an inspector cannot find a defect code corresponding to a violation of the TSS, the inspector may still submit the violation.

This chapter addresses Track Classes 1 through 5. Volume II, Chapter 2 of this manual addresses Classes 6 through 9.

#### **Subpart A – General**

##### **§ 213.1 Scope of part**

*(a) This part prescribes minimum safety requirements for railroad track that is part of the general railroad system of transportation. In general, the requirements prescribed in this part apply to specific track conditions existing in isolation. Therefore, a combination of track conditions, none of which individually amounts to a deviation from the requirements in this part, may require remedial action to provide for safe operations over that track. This part does not restrict a railroad from adopting and enforcing additional or more stringent requirements not inconsistent with this part.*

**Guidance:** It is important to note that the TSS are minimum safety requirements and are not appropriate for track maintenance purposes.

The VTI Final Rule (78 FR 16100, Mar. 13, 2013) added the phrase “In general” to provide a certain degree of flexibility, to encompass track conditions not necessarily “existing in

isolation.” In particular, it refers to “combined” track alignment and surface deviations contained in § 213.65.

While the TSS address specific track conditions that exist in isolation in general, there can sometimes be a combination of track conditions (none of which individually amounts to a deviation of the TSS) that require remedial action to provide for safe operations over that track. Section § 213.65 specifically addresses a combination of track conditions for curves with operations resulting in more than 5 inches cant deficiency. If an inspector encounters such a condition which is not encompassed in Section § 213.65, the inspector should also immediately bring the condition to the attention of the accompanying railroad official, explain the hazard of such a condition, and encourage its rapid removal. Where the inspector is not able to convince the railroad to initiate some action, the inspector should refer to the regional track specialist for assistance.

*(b) Subparts A through F apply to track Classes 1 through 5. Subpart G and §§ 213.2, 213.3, and 213.15 apply to track over which trains are operated at speeds in excess of those permitted over Class 5 track.*

**Guidance:** With the introduction of high-speed passenger train operations in the Nation, the TSS was revised in 1998 to provide two sets of requirements low speed/Classes 1 through 5 (Subpart A through to F), and high-speed/Classes 6 through 9 (Subpart G). The VTI Final Rule (78 FR 16100, Mar. 13, 2013) further revised the Part 213, but mainly Subpart G. The high-speed standards include specific requirements for such operations, which also prescribe a number of track-vehicle interaction tests, 213.3 (Application), and 213.15 (Penalties) apply to both high and low-speed track.

### **§ 213.3 Application**

*(a) Except as provided in paragraph (b) of this section, this part applies to all standard gage track in the general railroad system of transportation.*

**Guidance:** Paragraph 3(a) provides that, with certain exceptions listed in paragraph (b) (i.e., plant railroads including “leased track,” certain tourist, scenic, historic, and excursion operations, and certain rapid transit operations), Part 213 applies to all standard gage track in the general railroad system of transportation (general system). The term “general system” “refers to the network of standard gage track over which goods may be transported throughout the nation . . . .” 49 CFR Part 209, Appendix A.

*(b) This part does not apply to track:*

*(1) Located inside an installation that is not part of the general railroad system of transportation (i.e., a plant railroad). As used in this part, a plant railroad means a plant or installation that owns or leases a locomotive, uses that locomotive to switch cars throughout the plant or installation, and is moving goods solely for use in the facility’s own industrial processes. The plant or installation could include track immediately adjacent to the plant or installation if the plant railroad leases the track from the general system railroad and the lease provides for (and actual practice entails) the exclusive use of that track by the plant railroad and the general system railroad for purposes of moving only cars shipped to or from the plant. A plant or installation that operates a locomotive to switch or move cars for other entities, even if solely within the confines of the plant or installation, rather than for its own purposes or industrial processes, will not be considered a plant railroad because the performance of such activity*

*makes the operation part of the general railroad system of transportation. Similarly, this exclusion does not apply to track over which a general system railroad operates, even if that track is located within a plant railroad;*

*(2) Used exclusively for tourist, scenic, historic, or excursion operations that are not part of the general railroad system of transportation. As used in this part, tourist, scenic, historic, or excursion operations that are not part of the general railroad system of transportation means a tourist, scenic, historic, or excursion operation conducted only on track used exclusively for that purpose (i.e., there is no freight, intercity passenger, or commuter passenger railroad operation on the track); or*

*(3) Used exclusively for rapid transit operations in an urban area that are not connected to the general railroad system of transportation.*

*[63 FR 34029, June 22, 1998, as amended at 79 FR 4256, Jan. 24, 2014]*

**Guidance:** Although FRA’s statutory jurisdiction extends to all railroad carriers, FRA has chosen, as a matter of policy, not to impose its regulations on certain categories of rail operations. For example, 213.3(b)(1) excludes any railroad whose entire operation is confined to an industrial installation (i.e., a plant railroad), including “leased track,” that does not go beyond the plant’s boundaries onto the general railroad system of transportation (general system) from complying with the requirements of Part 213. Likewise, paragraph (b)(2) excludes tourist, scenic, historic, or excursion operations that are not part of the general system while paragraph (b)(3) excludes rapid transit operations in an urban area that are not connected to the general system. As provided in Appendix A to Part 209, the regulations are also not intended to make Part 213 applicable to certain rapid transit systems whose only connection to the general system is a switch permitting receipt of shipments of non-revenue materials from the general system.

FRA’s decision to not exercise its regulatory authority over track used in certain railroad operations in no way constrains the exercise of FRA’s statutory enforcement or emergency order authority under 49 U.S.C. 20104 and 20111. For example, FRA retains the authority to issue emergency orders to repair or discontinue use of trackage excluded from the requirements of Part 213 should FRA find that track conditions pose an emergency situation involving a hazard of death, personal injury, or significant harm to the environment. See 49 U.S.C. 20104. If FRA learns that a particular plant railroad is in such disrepair so as to pose a safety hazard of death or injury to a plant railroad employee, a railroad employee, or the public at large, FRA has the option of exercising its authority. FRA may issue an emergency order directing the plant railroad to discontinue using the track until specified repairs are made. It is FRA’s opinion that this emergency order is sufficient power to ensure track safety within plant railroads. If conditions or events in the future tend to demonstrate that track safety within plants or installations should be more closely regulated, FRA will seek to change the track safety regulations accordingly.

While FRA has chosen not to apply the requirements of Part 213 to trackage used in certain railroad operations, those operations should use the requirements as a guide to ensure that their tracks are capable of carrying rail traffic safely. For example, as a practical application of this policy, FRA expects that the trackage in a plant railroad, at a minimum, meet Class 1 standards. FRA expects that the requirements of Subparts C and D (geometry and

structure) of Part 213 will be met but does not expect a plant railroad to comply with inspection frequency requirements for its intended track class.

On January 24, 2014, FRA published a final rule which, for purposes of clarifying FRA's longstanding policy statement on its jurisdiction over "plant railroads" added a definition of the term "plant railroad" to Part 213. See 79 FR 4234 (Jan. 24, 2014) (Rail Integrity Final Rule). See also 213.3(b) cited above. That definition specifically stated that the plant railroad exclusion "does not apply to track over which a general system railroad operates, even if that track is located within a plant railroad." As stated throughout the preamble to that rulemaking document, however, FRA added the definition of "plant railroad" merely as a convenience for readers and intended the definition to be consistent with FRA's longstanding published policy statement on the extent and exercise of the agency's jurisdiction. FRA did not intend the Rail Integrity Final Rule to alter the reach of FRA's traditional exercise of jurisdiction over plant railroads or the applicability of Part 213. Accordingly, the requirements of FRA's TSS do not apply directly to railroads that meet the definition of "plant railroad," except that FRA expects that plant railroads will maintain that portion of their trackage used by a general system railroad in a safe condition and in compliance with Part 213, and FRA retains its enforcement authority and the authority to issue emergency orders to repair or discontinue use of industrial or plant trackage should FRA find that the track conditions pose an emergency situation involving a hazard of death, personal injury, or significant harm to the environment.

FRA also did not intend for the Rail Integrity Final Rule to alter FRA's approach to trackage located in an installation that is not part of the general system and that does not own, lease, or use a locomotive to move cars. FRA treats those installations as if they were plant railroads and does not generally apply the requirements of FRA's TSS to those installations. However, like a plant railroad, FRA expects that the installations will maintain that portion of their trackage used by a general system railroad in a safe condition and in compliance with Part 213. Moreover, FRA retains its enforcement authority and authority to issue emergency orders to repair or discontinue use of the trackage should FRA find that the track conditions pose an emergency situation involving a hazard of death, personal injury, or significant harm to the environment.

Any questions concerning the applicability of Part 213 must be referred to the regional track specialist, who will consult with the Office of Technical Oversight and the Office of Chief Counsel for guidance concerning the particular entity.

#### **§ 213.4 Excepted track**

*A track owner may designate a segment of track as excepted track provided that-*

*4(a) The segment is identified in the timetable, special instructions, general order, or other appropriate records which are available for inspection during regular business hours;*

**Guidance:** The intent of this section is to permit portions of certain low density main tracks and associated yard tracks and sidings to be allowed excepted status and not comply with Subparts B, C, D, and E of the TSS unless otherwise expressly stated. However, by designating a track as excepted, the owner must meet the requirements specified in paragraphs 4(b) through to 4(f).

*4(b) The identified segment is not located within 30-feet of an adjacent track which can be subjected to simultaneous use at speeds in excess of 10 miles per hour;;*



**Guidance:** This paragraph prohibits excepted track designation of any adjacent track located within a 30-foot envelope of a track that can be subjected to simultaneous use at speeds in excess of 10 mph. As shown in the following figure, the 30-foot dimension is measured between track centerlines and applies to all tracks within that area (e.g., tracks converging at turnouts and rail crossings). In this example, since the far left track operate at greater than 10 m.p.h., only the far right track may be excepted. Simultaneous use means movement of cars or locomotives on both tracks at the same time.

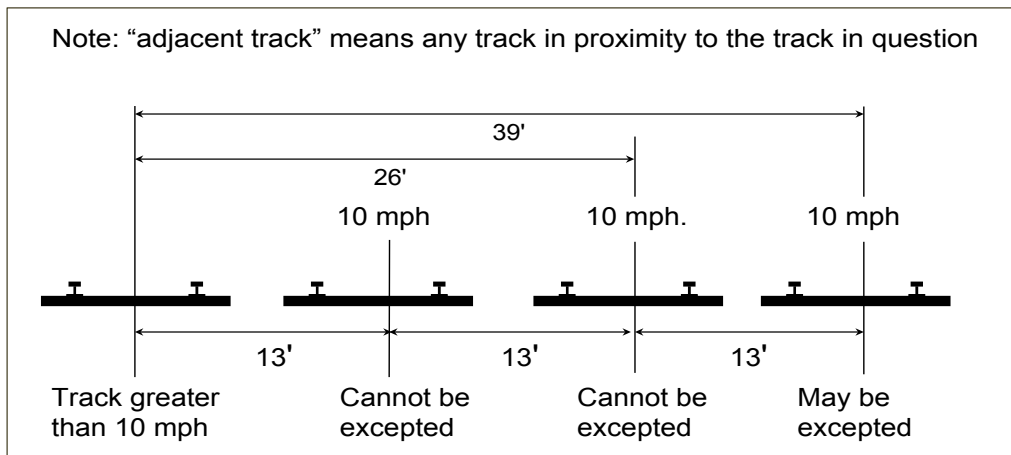

Operation on any track located within 30 feet of excepted track may be restricted to 10 mph by the physical layout of the tracks, or by definite restrictions placed by the track owner by rule, timetable, special instruction, or other positive instruction or order. These criteria provide the positive protection of trains on higher speed track against a collision with fouling equipment from a potential derailment on the excepted track.

The term "train" is defined in 49 CFR § 236.832 as, "A locomotive or more than one locomotive coupled, with or without cars". That definition applies to this rule.

A designation of excepted track need only be recorded by the track owner and implemented by issuance of appropriate instructions to all affected employees. The designation need not be filed with FRA. The TSS do not specify which employees the railroad or track owner must notify of excepted track designations; however, in order to ensure maximum safety and compliance with the requirements of this part, FRA recommends that railroad or track owner notify all employees who are involved with the operation of trains or with engineering functions on excepted track.

*4(c) The identified segment is inspected in accordance with 213.233(c) and 213.235 at the frequency specified for Class 1 track;*

**Guidance:** § 213.5(b) provides that a railroad may continue train operations on track segments designated as excepted track without complying with Subparts B, C, D, and E of Part 213. However, a railroad must still comply with the inspection requirements contained in Subpart F for track segments designated as excepted track. Railroads must inspect excepted track in accordance with §§ 213.233(c) and 213.235 at the frequency specified for Class 1 track. Failure to comply will result in a violation and loss of the excepted track privilege until inspection requirements specified in this paragraph are met.

*4(d) The identified segment of track is not located on a bridge including the track approaching the bridge for 100 feet on either side, or located on a public street or highway, if railroad cars containing commodities required to be placarded by the Hazardous Materials Regulations (49 CFR Part 172), are moved over the track; and*

**Guidance:** In the application of this paragraph, a public street or highway is defined as a roadway that is open to the public and is owned and maintained by a public entity. This paragraph includes both crossings of public roadways at grade and longitudinal running of the track for extended distances in a public roadway (street trackage).

Under § 214.7, a railroad bridge is defined as follows: 1) a railroad bridge is any structure supporting one or more railroad tracks with a span length of 12 feet or more measured along the track centerline; and 2) the term "bridge" shall apply to the entire structure between the faces of the backwalls of abutments or equivalent components, regardless of the number of spans. The term shall include all structures, whether of timber, stone, concrete, metal, or any combination thereof.

*4(e) The railroad conducts operations on the identified segment under the following conditions:*

- (1) No train shall be operated at speeds in excess of 10 miles per hour;*
- (2) No occupied passenger train shall be operated;*
- (3) No freight train shall be operated that contains more than five cars required to be placarded by the Hazardous Materials Regulations (49 CFR Part 172); and*
- (4) The gage on excepted track shall not be more than 4 feet 10¼ inches. (This paragraph (e)(4) is applicable September 21, 1999.)*

**Guidance:** In reference to (e)(1) through (4), a well-documented pattern of repeated or widespread deviations from these requirements by a track owner, including train operations in excess of 10 mph, will effectively terminate the privilege afforded by this section. The affected track would then become subject to all requirements of the TSS.

The word "occupied" in (e)(2) refers to paying and non-paying passengers. It does not include train crew members, track maintenance crews, and other railroad employees who must travel over the track to attend to their work duties.

The gage requirement only applies to the actual measurement itself under load, and does not extend to the evaluation of crossties and fasteners that provide the gage restraint. In the case of noncompliance with the gage requirement in excepted track, the railroad may invoke § 213.9(b) as remedial action. [See § 213.9(b) for restrictions.]

*4(f) A track owner shall advise the appropriate FRA Regional Office at least 10 days prior to removal of a segment of track from excepted status.*

**Guidance:** The railroad or track owner is required to notify the appropriate FRA Regional Office 10 days before removing trackage from excepted status. A railroad may not move the track from excepted to non-excepted status to operate an occupied passenger train or a train containing more than five cars placarded in accordance with 49 CFR Part 172, unless proper notification procedures are followed.

Inspectors will continue to inspect excepted track and report these inspections on the F6180.96 form. If serious deficiencies are discovered, they will be shown on the inspection form, noting that the track is in excepted status. The railroad or track owner would not be legally obligated by the TSS to correct the deficiencies noted, except for gage deviations in excess of 4 feet 10¼ inches (213 defect code 0053B5). However, if the condition of the track continues to constitute a hazard to life and limb and the track owner fails to alleviate the hazard, the inspector should notify the regional track specialist immediately. Issuance of an emergency order would be appropriate to address any serious defects that would pose an immediate safety threat to railroad employees or the public.

This notification provision is intended to prevent the practice FRA has witnessed in the past by some railroads. Specifically, those who remove trackage from excepted status only long enough to move a passenger excursion train or a train with more than five cars containing hazardous materials.

The following examples are provided to inspectors to determine compliance with the provision of excepted track.

Example One. On January 15, 2014, a railroad designates a 2-mile segment of its yard track Number 1, which is Class 1 track, as excepted track. The excepted track segment is located within 25 feet of an adjacent track over which simultaneous operations at speeds up to 20 mph are authorized. On January 25, 2014, an inspector discovers five locations in that segment at which Class 1 gage requirements are not being met.

Result: The segment of yard track Number 1 involved is ineligible for designation as excepted track because it violates § 213.4(b) simultaneous use restriction. Therefore, the segment remains subject to provisions of the TSS for Class 1 track. FRA may cite for correction or violation any deviation from the TSS discovered in the segment, such as the five gage defects. The railroad may also be cited, at the FRA inspector's discretion, for a violation of § 213.4(b) and will include the substantive defects (e.g., gage, alignment, crossties). As remedial action the railroad may authorize trains operations not to exceed 10mph speed restriction to include all tracks within 30-feet and adjacent to an excepted track, in effect removing the simultaneous use provision.

Example Two. A railroad designates yard track number 6, which is classified as Class 1 track, as excepted track on November 30, 2013. The railroad does not conduct any inspections over the track during December.

Result: Yard track number 6 loses its eligibility for designation as excepted track on January 1, 2014, and remains ineligible thereafter until the inspections required by § 213.4(c) begins. Starting January 1, 2014, the track becomes subject to all provisions of the TSS and remains subject to those requirements until such time as the inspections begin. Violation citations arising from inadvertent violations of the inspection requirement ordinarily should be issued only where safety was impaired or there is evidence of continued noncompliance.

In contrast to violations of the definitional (§ 213.4(a) to (d)) requirements, the unit of violation for noncompliance with the operational limitations is the train. We refer here to occasional and inadvertent noncompliance with operational limitations. A persistent and well-documented pattern of noncompliance with respect to a particular segment may cause

the railroad to lose its privilege of designating the segment as excepted track (i.e., the track would no longer qualify for such designation), or force FRA to use more drastic enforcement remedies such as emergency orders. The following examples illustrate this concept.

Example Three. A railroad properly designates a track segment as excepted track, 10 days later it operates a freight train containing 10 placarded tank cars over the track segment.

Result: One violation of § 213.4(e)(3) by the railroad has occurred, not five, because the unit of violation is the train rather than each of the placarded cars exceeding the five car limit. The segment continues to be excepted track because a violation of an operational limitation does not render the track ineligible for excepted track status.

Example Four. Railroad A properly designates one of its track segments as excepted track. Railroad B's freight train 2425, using the segment pursuant to a trackage rights agreement with Railroad A, operates over the segment at a speed of 20 mph.

Result: One violation has occurred of § 213.4(e)(2) by Railroad A. The track owner is the responsible party for illegal operations over the excepted track. The segment continues to be excepted track.

### **§ 213.5 Responsibility for compliance**

*5(a) Except as provided in paragraph (b) of this section, any owner of track to which this part applies who knows or has notice that the track does not comply with the requirements of this part, shall -*

- (1) Bring the track into compliance;*
- (2) Halt operations over that track; or*
- (3) Operate under authority of a person designated under § 213.7(a), who has at least one year of supervisory experience in railroad track maintenance, subject to conditions set forth in this part.*

**Guidance:** This paragraph describes the action that must be taken by a railroad or track owner once they know or have notice (knowledge standard) that the track is not in compliance with the TSS. The track owner must:

- (1) Bring the track into compliance by either repairing the defects or imposing an appropriate speed restriction.
- (2) Remove the track from service, that is, disallowing train operations.
- (3) Operate under authority of a qualified person designated under § 213.7(a) in accordance with one the following provisions:
  - § 213.9(b) Class of track – 30-day provision.
  - § 213.11 Restoration or renewal of track under traffic conditions.
  - § 213.113 Rail defects.

For additional information concerning the required corrective action for defects, see the guidance under § 213.9 (Classes of track; operating speed limit).

*5(b) If an owner of track to which this part applies designates a segment of track as “excepted track” under the provisions of § 213.4, operations may continue over that track without complying with the provisions of Subparts B, C, D, and E, unless otherwise expressly stated.*

**Guidance:** The owner may designate the track “excepted” provided it meets the requirements of § 213.4.

*5(c) If an owner of track to which this part applies assigns responsibility for the track to another person (by lease or otherwise), written notification of the assignment shall be provided to the appropriate FRA Regional Office at least 30 days in advance of the assignment. The notification may be made by any party to that assignment, but shall be in writing and include the following —*

- (1) The name and address of the track owner;*
- (2) The name and address of the person to whom responsibility is assigned (assignee);*
- (3) A statement of the exact relationship between the track owner and the assignee;*
- (4) A precise identification of the track;*
- (5) A statement as to the competence and ability of the assignee to carry out the duties of the track owner under this part; and*
- (6) A statement signed by the assignee acknowledging the assignment to him of responsibility for purposes of compliance with this part.*

**Guidance:** Paragraph 5(c) requires a track owner to notify FRA, through the appropriate regional office, when the responsibility for compliance with this part is assigned to another. Notification must contain the specific information required in this paragraph and shall be made 30 days before the assignment of the responsibility.

*5(d) The Administrator may hold the track owner or the assignee or both responsible for compliance with this part and subject to penalties under 213.15.*

**Guidance:** Where the track is not owned by the operating railroad through an arrangement such as a lease agreement, typically the operating railroad will be cited for violations. However, it may be appropriate to recommend civil penalties against the operating railroad and the owner when both parties contributed to the deficiency. Inspectors must determine the responsible party when recommending civil penalties for noncompliance and alert FRA’s Chief Counsel when violation reports involve parties other than the track owner.

This paragraph also provides that the party responsible for compliance can be other than the actual owner of the track through assignment of responsibility or if the Surface Transportation Board (formerly Interstate Commerce Commission) has issued a directed service order. FRA may hold responsible any party contracted by the track owner to ensure compliance with this part. FRA may hold the track owner, the assignee, or both responsible.

*5(e) A common carrier by railroad which is directed by the Surface Transportation Board to provide service over the track of another railroad under 49 U.S.C. 11123 is considered the owner of that track for the purposes of the application of this part during the period the directed service order remains in effect.*

**Guidance:** On rare occasions, such as a cessation of service by a railroad, the Surface Transportation Board directs a railroad, other than the track owner, to provide service, the designated operator shall be considered as the owner for the purposes of compliance of the TSS.

*5(f) When any person, including a contractor for a railroad or track owner, performs any function required by this part, that person is required to perform that function in accordance with this part.*

**Guidance:** Both employees of railroads and track owners, and contractors to railroads, are subject to the requirements of the TSS when they perform functions required by the TSS.

### **§ 213.7 Designation of qualified persons to supervise certain renewals and inspect track**

*7(a) Each track owner to which this part applies shall designate qualified persons to supervise restorations and renewals of track under traffic conditions. Each person designated shall have—*

- (1) At least —*
  - (i) 1 year of supervisory experience in railroad track maintenance; or*
  - (ii) A combination of supervisory experience in track maintenance and training from a course in track maintenance or from a college level educational program related to track maintenance;*
- (2) Demonstrated to the owner that he or she—*
  - (i) Knows and understands the requirements of this part that apply to the restoration and renewal of the track for which he or she is responsible;*
  - (ii) Can detect deviations from those requirements; and*
  - (iii) Can prescribe appropriate remedial action to correct or safely compensate for those deviations; and*
- (3) Written authorization from the track owner to prescribe remedial actions to correct or safely compensate for deviations from the requirements in this part.*

*7(b) Each track owner to which this part applies shall designate qualified persons to inspect track for defects. Each person designated shall have—*

- (1) At least—*
  - (i) 1 year of experience in railroad track inspection; or*
  - (ii) A combination of experience in track inspection and training from a course in track inspection or from a college level educational program related to track inspection;*
- (2) Demonstrated to the owner that he or she—*
  - (i) Knows and understands the requirements of this part that apply to the inspection of the track for which he or she is responsible;*
  - (ii) Can detect deviations from those requirements; and*
  - (iii) Can prescribe appropriate remedial action to correct or safely compensate for those deviations; and*
- (3) Written authorization from the track owner to prescribe remedial actions to correct or safely compensate for deviations from the requirements of this part, pending review by a qualified person designated under paragraph (a) of this section.*

**Guidance:** Inspectors may request verification of the experience and qualifications of the supervisory and track inspection personnel from a track owner. The submission of a seniority roster or job awarding bulletin is not to be considered as satisfactory identification of qualified employees or as a basis for their designation. The owner should make specific names of individuals and their qualifications available in writing. If the inspector is in doubt as to the qualifications of the owner's supervisory or inspection personnel, the inspector should examine the owner's inspection records. The TSS require the retention of track inspection reports for 1 year. Should the records consistently fail to reflect the actual track conditions, questions can be raised as to the competence and/or qualifications of the persons included in the list.

Paragraphs (a)(2)(i) and (b)(2)(i) clarify that the requirements for a person to be qualified under this section concern the portions of Part 213 necessary for the person to perform his/her duties. The person is not required to know or understand specific requirements of this part not necessary to fulfill his or her duties. For example, track foremen and inspectors may not be required to know or understand vehicle qualification and testing requirements for high cant deficiency operations in track Classes 1 to 5 in fulfilling their duties.

When in doubt as to the qualifications of an owner's supervisors or inspectors, the inspector should discuss the matter with the railroad.

*7(c) Individuals designated under paragraphs (a) or (b) of this section that inspect continuous welded rail (CWR) track or supervise the installation, adjustment, and maintenance of CWR track in accordance with the written procedures of the track owner shall have:*

- (1) Current qualifications under either paragraph (a) or (b) of this section;*
- (2) Successfully completed a comprehensive training course specifically developed for the application of written CWR procedures issued by the track owner;*
- (3) Demonstrated to the track owner that the individual:*
  - (i) Knows and understands the requirements of those written CWR procedures;*
  - (ii) Can detect deviations from those requirements; and*
  - (iii) Can prescribe appropriate remedial action to correct or safely compensate for those deviations; and*
- (4) Written authorization from the track owner to prescribe remedial actions to correct or safely compensate for deviations from the requirements in those procedures and successfully completed a recorded examination on those procedures as part of the qualification process.*

**Guidance:** As CWR track has characteristics inherently different than those of traditional jointed rail, track owners are required to designate which individuals are specifically qualified to inspect or supervise the installation, adjustment, and maintenance of CWR. In addition to the qualifications that an individual must have under either paragraph (a) or (b), an individual designated under paragraph (c) must have completed a CWR training course and be well-versed in the maintenance of CWR track as detailed in the track owner's CWR plan. The comprehensive nature of the training course is more important than its duration; therefore, the railroad employee must successfully complete an in-depth initial training course of the track owner's written CWR procedures and continue subsequent periodic re-training thereafter, pursuant to the training program required by § 213.343(g). In addition, all individuals qualified on CWR for train operations must successfully complete a recorded

examination on the track owner's CWR procedures. This recorded examination may be, for example, a traditional written examination, an electronic file of a computerized interactive training course that concludes with an examination, or a record of a supervisor's oral testing of the employee's knowledge through practical field application. Due to the language of the regulation, track owners have flexibility to test an individual's knowledge to one of the previously stated methods. However, it should be noted that the results of the examination must be recorded so that FRA may inspect the basis for the qualification of an individual under paragraph (c).

*7(d) Persons not fully qualified to supervise certain renewals and inspect track as required in paragraphs (a) through (c) of this section, but with at least one year of maintenance-of-way or signal experience, may pass trains over broken rails and pull aparts provided that—*

- (1) The track owner determines the person to be qualified and, as part of doing so, trains, examines, and re-examines the person periodically within two years after each prior examination on the following topics as they relate to the safe passage of trains over broken rails or pull aparts: rail defect identification, crosstie condition, track surface and alinement, gage restraint, rail end mismatch, joint bars, and maximum distance between rail ends over which trains may be allowed to pass. The sole purpose of the examination is to ascertain the person's ability to effectively apply these requirements and the examination may not be used to disqualify the person from other duties. A minimum of four hours training is required for initial training;*
- (2) The person deems it safe and train speeds are limited to a maximum of 10 m.p.h. over the broken rail or pull apart;*
- (3) The person shall watch all movements over the broken rail or pull apart and be prepared to stop the train if necessary; and*
- (4) Person(s) fully qualified under § 213.7 are notified and dispatched to the location promptly for the purpose of authorizing movements and effecting temporary or permanent repairs.*

**Guidance:** Paragraph (d) allows employees to be qualified for the specific purpose of authorizing train movements over broken rails or pull-aparts. This section requires the employees to have at least 1 year of maintenance-of-way or signal experience and a minimum of 4 hours of training, plus an examination (and periodic re-examination within 2 years of each examination) on requirements related to the safe passage of trains over broken rails and pull-aparts. The purpose of the examination is to ascertain the person's ability to effectively apply these requirements. A railroad may use the examination to determine whether a person should be allowed to authorize train movements over broken rails or pull-aparts.

The maximum speed over broken rails and pull-aparts shall not exceed 10 mph. However, movement authorized by a person qualified under this subsection may further restrict speed, if warranted by the particular circumstances. The person qualified under this paragraph must be present at the site and able to instantly communicate with the train crew so that the movement can be stopped immediately, if necessary.

Fully qualified persons under § 213.7 must be notified and dispatched to the location promptly to assume responsibility for authorizing train movements and effecting repairs. The word "promptly" is meant to provide the railroad with flexibility to pass trains over the condition prior to the time the fully qualified person would report to the scene. Railroads may permit persons qualified under § 213.7(d) to authorize multiple train movements over



such conditions, but the person qualified under § 213.7(d) must examine the broken rail or pull-apart area initially, and before each subsequent movement, to ensure the location is safe for the passage of the next train.

7(e) *With respect to designations under paragraphs (a) through (d) of this section, each track owner shall maintain written records of—*

- (1) *Each designation in effect;*
- (2) *The basis for each designation; and*
- (3) *Track inspections made by each designated qualified person as required by § 213.241. These records shall be kept available for inspection or copying by the Federal Railroad Administration during regular business hours.*

**Guidance:** Failure of the owner to have and maintain written records designating employees and the basis for each designation is a deviation from the TSS. Incomplete qualification records would also constitute a deviation from the standards. Designated employees include supervisors, inspectors, and those partially qualified to pass trains over broken rails and pull-aparts. Inspectors are also instructed to note that incomplete qualification records may not reflect the actual qualification of an individual. As such, a record deficiency shall not be the sole basis for a defect or civil penalty recommendation for not having a qualified designated person performing these functions. If there are questions about the qualifications of an individual, it will be necessary for the inspector to interview railroad or contractor employees.

### **§ 213.9 Classes of track: operating speed limits**

9(a) *Except as provided in paragraph (b) of this section and §§213.57(b), 213.59(a), 213.113(a), and 213.137(b) and (c), the following maximum allowable operating speeds apply-*

*[In miles per hour]*

<b><i>Over track that meets all of the requirements prescribed in this part for</i></b>	<b><i>The maximum allowable speed for freight trains is</i></b>	<b><i>The maximum allowable speed for passenger trains is</i></b>
<i>Excepted</i>	<i>10</i>	<i>N/A</i>
<i>Class 1 track</i>	<i>10</i>	<i>15</i>
<i>Class 2 track</i>	<i>25</i>	<i>30</i>
<i>Class 3 track</i>	<i>40</i>	<i>60</i>
<i>Class 4 track</i>	<i>60</i>	<i>80</i>
<i>Class 5 track</i>	<i>80</i>	<i>90</i>

**Guidance:** The TSS classifies track solely on the basis of authorized speeds for freight and passenger trains. Tolerances are specified in the TSS for each class of track. A deviation beyond the limiting tolerances for Classes 1 through 5 requires repair, or reduction of speeds to the appropriate class. The only structural or geometry defect that is applicable on excepted track is gage exceeding 4 feet 10¼ inches.

The initial speed of any track is based on the design characteristics of the track. FRA does not set the speed, and railroads are required to keep track in compliance with the requirements of Part 213. In addition to track design characteristics, speeds may be set by other factors such as the type of signal apparatus. Maximum speeds are also limited if a signal system is not in place on a track (refer to 49 CFR § 236 for further information).

If a deviation exceeds Class 1 standards, operations may continue for not more than 30 days over the deviation, not exceeding Class 1 speeds. This is only permitted after a person designated and qualified in the provisions of § 213.7(a), determines that operations may safely continue and specifies limiting conditions, if any. The designated person must have personally seen and evaluated the deviation. This section may also govern a deviation exceeding allowable gage on excepted track.

As described in paragraph (a), the maximum allowable operating speed for each class of track is shown in the table. However, the maximum allowable operating speed on a curve is also limited by the geometry parameters contained in § 213.57(b) [Unbalance] and § 213.59(a) [Superelevation]. For example, a speed for a passenger train based on the elevation at a curve may be only 18 mph, even though the track may otherwise comply with a higher track class.

The rule is to provide a railroad or track owner additional flexibility in resolving defective conditions while continuing rail service over the track. One loose frog bolt, out of several, would seldom constitute an immediate hazard, provided that the frog was otherwise secure. On the other hand, a missing cotter pin in a critical location such as in a connecting rod could have serious consequences.

One or two loose braces are usually not considered to be an immediate hazard, provided that the other braces are in acceptable functional condition to support the stock rail. On the other hand, several consecutively loose braces, especially in the higher track classes, could be much more serious.

Intermittent patches of vegetation that brush the sides of rolling stock may not be an immediate hazard, but more severe vegetation might have the potential of contributing to the injury of an employee who is riding on the side of a car or looking out locomotive cab windows. The specific description for this type of defect is “vegetation brushing sides of rolling stock that prevents employees from visually inspecting moving equipment from their normal duty stations” (213 defect code 0037E3).

As the above examples illustrate, non-class-specific defects (not associated with a particular track classification) must be considered in the context of the specific circumstances involved. The existence of a non-class-specific defect under one set of circumstances may not be serious, while the identical condition under other circumstances may constitute a serious safety concern.

Although some non-class-specific defects may not present an immediate hazard, these conditions will only degrade under train traffic. Therefore, it is important for the railroad or track owner and FRA inspectors to record these defects for remedial or corrective action. In summary:

1. Record all noncomplying conditions, including non-class-specific defects such as loose or missing frog bolts or switch braces. Care must be taken to conduct a thorough inspection, recording the location, type, and size of each defect discovered.
2. Evaluate the remedial action taken by the carrier. If an inspector becomes aware that the remedial action, or lack thereof, for a non-class-specific defect is not sufficient based on the circumstances, the inspector should seek a more appropriate action from the carrier. For a non-class-specific defect that is an imminent hazard, such as a missing nut on a connecting rod, the inspector should immediately inquire as to the remedial action planned by the carrier.
3. If the railroad does not initiate an appropriate remedial action, the inspector should consider recommending a violation. If the railroad has been advised that a violation has been recommended and has not initiated appropriate remedial action, the inspector should be prepared to issue a Special Notice for Repairs, under the guidelines described in Chapter 4 of this manual.
4. In the case of a non-class-specific defect that did not pose an immediate hazard when the defect was recorded and the inspector discovers that no action was taken within a reasonable time frame after the carrier had knowledge of the defect, the inspector should consider the enforcement options described in item 3 above. In any case, if no appropriate action was taken within a 30-day period, the inspector should consider the enforcement tools outlined above.

When a railroad inspector discovers a non-class-specific defect (as with all defects) the railroad inspector must initiate immediate action in accordance with § 213.233(d). The remedial action taken by the railroad inspector must be recorded in accordance with § 213.241(b). For non-class-specific defects, the record must show a reasonable explanation of the action taken. For example, “repaired before next train” would be appropriate for serious conditions. On the other hand, a notation for a defect such as vegetation that indicates it is scheduled for cutting by a weed mower by a specific date within 30-days may be appropriate.

When a railroad representative places a slow order on a segment of track for a defect for immediate corrective action, any other items within the same slow order segment would be “protected”. For example, an FRA inspector finds a defect at Milepost (MP) 5.5 and railroad immediately places a slow order from MP 5.0 to MP 6.0. During the same inspection, the FRA inspector also finds a condition at MP 5.8 that would be a defect without the speed restriction. While the defect at MP 5.8 is under the slow order just imposed, it was obviously a defect prior to the placement of the temporary restriction. The FRA inspector can record a defect at MP 5.8.

A non-class-specific defect may not pose an immediate hazard for one train movement, but the condition may deteriorate to become a hazard to following trains. It is reasonable to expect that conditions such as loose or missing frog bolts or braces be repaired as quickly as possible. However, a qualified railroad representative under § 213.7 may determine that the condition is not an immediate hazard and decide to call for assistance to make the repairs, or the representative may decide to end the inspection, retrieve the necessary repair materials, and return later to make the repairs. In some cases, the representative may determine that a speed restriction is appropriate.

When non-class-specific defects are scheduled for repair, railroad inspectors shall continue to report the defect on their inspection reports until it is corrected. However, the 30-day limit for any given defective condition cannot be exceeded.

*9(b) If a segment of track does not meet all of the requirements for its intended class, it is reclassified to the next lowest class of track for which it does meet all of the requirements of this part. However, if the segment of track does not at least meet the requirements for Class 1 track, operations may continue at Class 1 speeds for a period of not more than 30-days without bringing the track into compliance, under the authority of a person designated under § 213.7(a), who has at least one year of supervisory experience in railroad track maintenance, after that person determines that operations may safely continue and subject to any limiting conditions specified by such person.*

**Guidance:** A track segment must meet all the requirements for its designated class. Where a track segment does not meet all the requirements, railroads can reclassify the segment for the next lowest class for which it complies. For example, on a Class 3 Track, where the alinement mid-chord offset from a 62-foot chord on a tangent track measured 2-inches, the railroad can elect to reduce the speed equivalent to Class 2 track.

Trains may continue to operate over a noncomplying condition under § 213.9(b). However, the 30-day limit for any given condition cannot be exceeded. The 30-day period commences when:

- An FRA inspector notifies the carrier or issues notice with a F6180.96 form.
- A person designated under § 213.7 records the defect on a track owner's record of inspection.
- Notices of substandard conditions are received from third parties.
- The track owner is deemed to have constructive knowledge if the defects were discoverable through properly performed track inspections required by the TSS, even if the defects are not reported on the owner's record of inspection.

Several other points concerning § 213.9(b) should be noted:

- FRA inspectors should not attempt to predict an exact date on which a sub-Class 1 defect first existed. In most cases, a reasoned approximation (with accompanying explanation of the basis for the inspector's conclusions) will be sufficient to show that § 213.9(b) is not available to the track owner. Because of the serious enforcement problems presented by application of the constructive knowledge test, inspectors should use this authority judiciously.
- Once a determination has been made that operations may safely continue over a segment, the 30-day period applies to all sub-Class 1 defects present in the segment at that time. The 30-day period is an appropriate remedial action for sub-Class 1 defects and the 30-day period can only be applied one time. At the expiration of the 30-day period, the defects must be repaired, track placed into excepted track status, or the track must be removed from service.
- The limiting conditions, if any, placed on operations must be in a form generally used by the track owner to communicate operating restrictions to its personnel and to any other railroads authorized to use the track involved. If a train operating over the track fails to comply with any such condition, one violation of § 213.9(b) by the track owner has occurred, regardless of the identity of the operator of the train.
- Section 213.9(b) does not apply where defective rails are involved. Section 213.113 exclusively governs further operations over defective rails.

The following table shows examples of those sections in the TSS that are “class specific,” “speed defined” and “non-class-specific.” This table is not all-inclusive and is only a reference instrument. Inspectors should refer to the specific guidance under each section for further details and instructions on each item listed in the table.

Section	Topic	Class specific	Speed defined	Non-class-specific [1]
213.33	Drainage			X
213.37	Vegetation			X
213.57(b)	Curves; elevation and speed limitations (V-Max)		X	
213.103	Ballast; general			X
213.109(b)	Crossties not effectively distributed			X
213.110	Gage Restraint Measurement Systems	X		
213.113	Defective rails		X	
213.119	Continuous welded rail; general			X
213.121 (a)	Each rail joint, insulated joint, and compromise joint shall be of a structurally sound design and dimensions for the rail on which it is applied			X
213.121 (c)	If a joint bar is cracked or broken between the middle two bolt holes it shall be replaced	X[3]		
213.121 (d)	In the case of conventional jointed track, each rail shall be bolted..., and with at least one bolt on Class 1 track	X		
213.121 (e)	In the case of continuous welded rail track, each rail shall be bolted with at least two bolts at each joint	X[3]		
213.121 (f)	Each joint bar shall be held in position by track bolts tightened to allow the joint bar to firmly support the abutting rail ends.....			X
213.127	Rail fastenings			X
213.133 (a)	Turnouts and track crossings generally			X [2]
213.133(b)	Classes 3 through 5 ... shall be equipped with anchors on each side of track crossings and turnouts...	X		

Section	Topic	Class specific	Speed defined	Non-class-specific [1]
213.133(c)	Each flangeway at turnouts and track crossings shall be at least 1½ inches wide	X		
213.135(a)	Each stock rail must be securely seated in switch plates...			X
213.135(b)	Each switch point shall fit its stock rail		X	X
213.135(c)	Each switch shall be maintained so that the outer edge of the wheel tread cannot contact the gage side of the stock rail.			X[2]
213.135(d)	The heel of each switch rail shall be secure....			X
213.135(e)	Each switch stand and connecting rod shall be securely fastened....			X
213.135(f)	Each throw lever shall be maintained so that it cannot be operated with the lock or keeper in place.			X [2]
213.135(g)	Switch position indicator			X
213.135(h)	Unusually worn or chipped switch points...			X [2]
213.135(i)	Tongue and plain mate switches...	X		
213.137(b)	If a frog point is chipped, broken, or worn more than 5/8 inch down and 6 inches back, operating speed over that frog may not be more than 10 mph		X	
213.137(c)	If the tread portion of a frog casting is worn down more than 3/8 inch below the original contour, operating speed over that frog may not be more than 10 mph		X	
213.139(a)	The outer edge of a wheel shall not contact the gage side of a spring wing rail.			X [2]
213.139(b)	The toe of each wing rail shall be solidly tamped...			X
213.139(c)	Each frog with a bolt hole defect or head-web separation shall be replaced.	X		
213.139(d)	Each spring shall have compression...			X
213.139(e)	The clearance between the holddown housing and horn...			X
213.141	Self-guarded frogs	X		
213.205	Derails			X

Section	Topic	Class specific	Speed defined	Non-class-specific [1]
	<p>[1] Non-class-specific defects found during an inspection by a qualified railroad inspector and not immediately repaired must be noted on the track inspection form. If not immediately repaired, remedial action shall be taken by an individual qualified under § 213.7 (a). The 30-day period represents the maximum duration that FRA permits any non-class-specific defect(s) to remain in the track. Furthermore, it is not intended to create a 30-day timeline for all types of defects as immediate repair or a more restrictive appropriate action may be required at the time of the defect(s) discovery.</p> <p>[2] While Part 213 does not require the railroad to take the track out of service, due to the severity of these defects, FRA recommends that railroads take the track out of service. At a minimum, however, the railroad should invoke § 213.9(b).</p> <p>[3] This class specific defect requires remedial action § 213.9(b).</p>			

### § 213.11 Restoration or renewal of track under traffic conditions

*If, during a period of restoration or renewal, track is under traffic conditions and does not meet all of the requirements prescribed in this part the work on the track shall be under the continuous supervision of a person designated under §213.7(a) who has at least one year of supervisory experience in railroad track maintenance, and subject to any limiting conditions specified by such a person. The term “continuous supervision” as used in this section means the physical presence of that person at a job site. However, since the work may be performed over a large area, it is not necessary that each phase of the work be done under the visual supervision of that person.*

**Guidance:** This section specifies that a person designated under § 213.7(a) must provide continuous supervision during work periods when track with conditions not complying with the designated class is under traffic conditions. The section is specific in that each phase of the restoration or renewal need not be under the visual supervision of that person, but the person must be present at the job site in direct control of the work and have direct knowledge of the condition of the track over which they permit a train or trains to pass.

The qualified person at a work site may determine that it is safe to permit a train to pass through the work area at any speed up to the permanent speed on the track. For example, during a crosstie and resurfacing project, the qualified person may analyze the conditions present and authorize a speed higher than 10 mph through the limits of the work when temporary crosslevel conditions exceed the limits in § 213.63 for Class 1 track. Similarly, a welder may permit a train to pass over a frog when the welding and grinding process temporarily removes the point more than 6 inches back and 5/8-inch down. At the end of the work period, when the designated person leaves the work site, the track must be in compliance with the TSS. It is acceptable for the designated person to determine that the track is safe for operation at Class 1 speeds and use § 213.9(b) as a remedial action.

Continuous supervision may be met if the work is broken into a number of segments over a large area. Inspectors must use judgment and experience in applying this limitation to the general rule. The essential questions are whether the specific circumstances of a given project actually permit effective supervision by the designated person, and whether such supervision is being properly exercised. An example of an acceptable application of this paragraph would be a large tie and surfacing unit that has cleared a track for a short period to allow the passage of a train based on the qualified person determining that the track is safe for operation. On the other hand, if a switch gang is working separately from the tie

and surfacing crew in the same general vicinity, a qualified person must be with that work unit.

### § 213.13 Measuring track not under load

When unloaded track is measured to determine compliance with requirements of this part, the amount of rail movement, if any, that occurs while the track is loaded must be added to the measurements of the unloaded track.

**Guidance:** In addition to the static (unloaded) geometry measurements taken, the amount of visually detectable dynamic (loaded) deflection that occurs under train movement must be considered. This includes the amount of vertical or lateral rail deflection occurring between a rail base and a tie plate or a tie plate and a crosstie; from voids between the crosstie and ballast section resulting from elastic compression; or any combination of the above. Each deflection under the running rails must be measured and properly considered when computing the collective deviations under load. It is very important that consideration be given to both rails when measuring these deflections.

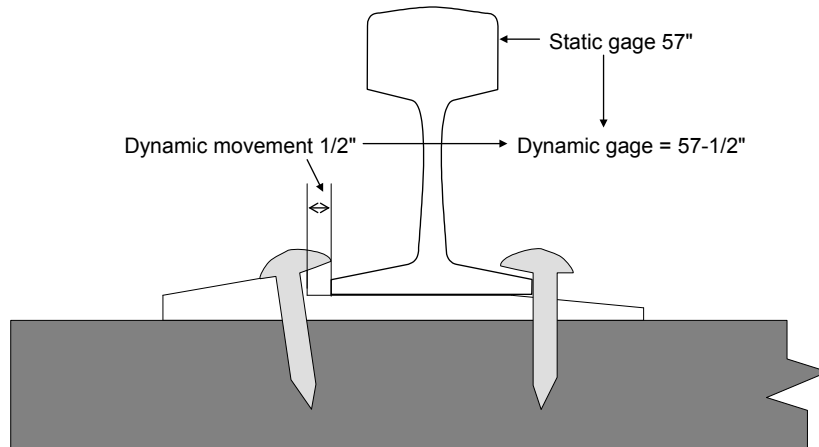

Vertical and lateral deflections may be found at locations such as rail joints and turnout locations with poor wooden crossties and conventional cut-spike fastening conditions or at bridge abutments and over culverts where the subgrade has settled.

### §213.14 Application of requirements to curved track.

Unless otherwise provided in this part, requirements specified for curved track apply only to track having a curvature greater than 0.25 degree.

**Guidance:** The section defines what is meant by curved track for the purpose of application of requirements for curved track. Unless otherwise provided in this part, requirements specified for curved track apply only to track having a curvature greater than 0.25 degree. This definition is intended to apply in all sections where limits for curved track are specified, unless otherwise provided.

Please note that, by implication of this section, track measurement systems required for compliance with part 213 must be able to detect curves with this minimum specified degree of curvature.



### § 213.15 Penalties

15(a) Any person who violates any requirement of this part or causes the violation of any such requirement is subject to a civil penalty of at least \$650 and not more than \$25,000 per violation, except that: Penalties may be assessed against individuals only for willful violations, and, where a grossly negligent violation or a pattern of repeated violations has created an imminent hazard of death or injury to persons, or has caused death or injury, a penalty not to exceed \$105,000 per violation may be assessed. “Person” means an entity of any type covered under 1 U.S.C. 1, including but not limited to the following: a railroad; a manager, supervisor, official, or other employee or agent of a railroad; any owner, manufacturer, lessor, or lessee of railroad equipment, track, or facilities; any independent contractor providing goods or services to a railroad; any employee of such owner, manufacturer, lessor, lessee, or independent contractor; and anyone held by the Federal Railroad Administrator to be responsible under §213.5(d) or §213.303(c). Each day a violation continues shall constitute a separate offense. See Appendix B to this part for a statement of agency civil penalty policy.

15(b) Any person who knowingly and willfully falsifies a record or report required by this Part may be subject to criminal penalties under 49 U.S.C. 21311.

**Guidance:** This section covers all subparts of Part 213, including a schedule of civil penalties found under Appendix B to Part 213 – Schedule for civil Penalties..

### § 213.17 Waivers

17(a) Any owner of track to which this part applies, or other person subject to this part, may petition the Federal Railroad Administrator for a waiver from any or all requirements prescribed in this part. The filing of such a petition does not affect that person’s responsibility for compliance with that requirement while the petition is being considered.

**Guidance:** Inspectors have no authority under the TSS to grant waivers.

17(b) Each petition for a waiver under this section must be filed in the manner and contain the information required by Part 211 of this chapter.

**Guidance:** Per 49 CFR 211.7(b) and 211.45(f), any petition for waiver must be filed by the owner or designated operator with the Docket Clerk, Office of Chief Counsel, in Washington, D.C. The petition can also be filed by a trade association, such as Association of American Railroads (AAR), on behalf of its members. In addition to this chapter, inspectors should also reference the FRA Office of Railroad Safety’s General Manual, Chapter 5 Complaint and Waiver Investigations, for guidance and information regarding waiver procedures.

General Manual, Chapter 5 indicates that waiver petitions may also be addressed to a FRA manager or specialist. In the past, most petitions have been addressed to the chairperson of the FRA Railroad Safety Board as most waivers are decided by the board.

17(c) If the Administrator finds that a waiver is in the public interest and is consistent with railroad safety, the Administrator may grant the exemption subject to any conditions the Administrator deems necessary. Where a waiver is granted, the Administrator publishes a notice containing the reasons for granting the waiver.

**Guidance:** Typically, waivers bear the signature of AA/Chief Safety Officer, or his/her delegate. Inspectors should keep updated with any waivers in effect in their assigned territory which are relevant to their job activities.

### **§213.19 Information collection**

*19(a) The information collection requirements of this part were reviewed by the Office of Management and Budget pursuant to the Paperwork Reduction Act of 1995 (44 U.S.C. 3501 et seq.) and are assigned OMB control number 2130-0010.*

*19(b) The information collection requirements are found in the following sections: §§213.4, 213.5, 213.7, 213.17, 213.57, 213.119, 213.122, 213.233, 213.237, 213.241, 213.303, 213.305, 213.317, 213.329, 213.333, 213.339, 213.341, 213.343, 213.345, 213.353, 213.361, 213.369.*

## **Subpart B – Roadbed**

### **§ 213.31 Scope**

*This subpart prescribes minimum requirements for roadbed and areas immediately adjacent to roadbed.*

### **§ 213.33 Drainage**

*Each drainage or other water carrying facility under or immediately adjacent to the roadbed must be maintained and kept free of obstruction, to accommodate expected water flow for the area concerned.*

**Guidance:** One of the most essential elements of track maintenance is a comprehensive drainage system. Drainage facilities (bridges, trestles, or culverts) should be given careful detailed consideration during inspections. Openings under the track are used to channel and divert water from one side of the roadbed to the other.

The rule specifies that each drainage structure shall be maintained and the inspector should note conditions that would affect the integrity of the structure, such as culvert pull-aparts or separations, crushing or uneven settlement due to failure of or lack of head walls (in conjunction with frost action), too steep a gradient, and insufficient support.

Drainage openings must also be inspected and notice given where debris has accumulated to such an extent that expected water flow cannot be accommodated.

Most railroad drainage structures have existed for many years and, if properly maintained and kept free of debris, they are considered adequately designed to accommodate expected water flow, even though recent high-water marks may be slightly above the inlet opening.

Culverts designed with submerged inlets are common. Where questions are raised concerning the adequacy of drainage structures, the regional track specialist should be consulted.

Inspectors must take note of the conditions of:

- Right-of-way ditches.

- Culverts, trestles, and bridge inlets.
- Water carrying structures or passageways.
- Outlets or tail ditches.
- Berm ditches.
- Scouring of embankments, piling or piers in channels or at abutments.
- Filling in of passageways from silting, sand wash, or debris.

Inspectors must notify the track owner of any drainage condition deemed hazardous, or potentially hazardous, to the safety of train operations over the track.

### **§ 213.37 Vegetation**

*Vegetation on railroad property which is on or immediately adjacent to roadbed shall be controlled so that it does not --*

*37(a) Become a fire hazard to track-carrying structures;*

**Guidance:** Inspectors must be aware that live and dead growth, drift, tumbleweeds, debris, etc., can constitute fire hazards to timber bridges, trestles, wooden box culverts, and other track carrying structures.

*37(b) Obstruct visibility of railroad signs and signals;*

*(1) along the right-of-way, and*

*(2) at highway-rail crossings; (This paragraph (b)(2) is applicable September 21, 1999.)*

**Guidance:** This paragraph includes a requirement to clear vegetation from signs and signals along railroad rights-of-way and at highway-rail grade crossings. Because the scope of Part 213 limits vegetation requirements to railroad property, this is not intended to be an attempt to dictate standards for surrounding landowners. This paragraph also requires signs and signals on railroad property at highway-rail grade crossings be kept clear of vegetation and is intended to provide adequate visibility of these devices for the traveling public. It is not intended to preempt State or local requirements for the clearing of vegetation on railroad rights-of-way at highway-rail grade crossings.

Obstruction of the visibility of railroad signs and signals by vegetation is a deviation from the TSS. Although all signals are important, the visibility of certain signals must be closely observed [i.e., block signals, interlocking signals, speed signs (or other signs affecting the movement of trains), close clearance signs, whistle posts, and mileposts].

*37(c) Interfere with railroad employees performing normal trackside duties;*

**Guidance:** Judgment must be exercised by the inspector in determining whether trackside vegetation will interfere with the railroad employees' performance of normal trackside duties. Weeds covering the track that hinder the ability of an inspector to see track structure components is not necessarily a noncomplying condition.

*37(d) Prevent proper functioning of signal and communication lines; or*

**Guidance:** Before citing the railroad for vegetation interfering with signal or communication lines, the inspector must confirm that the line is active. Occasionally, inspectors may

observe vegetation in lines that they are unsure if they are functional. Communication between the Track inspector and the FRA Signal and Train Control inspector is necessary if the railroad representative cannot confirm the status of a signal or communication line. When interfering with active lines, vegetation may cause false signal indications and/or disrupt communications that are vital to safe train operations. When there are questions regarding vegetation and the signal lines, joint inspections by track and signal personnel are encouraged. The Track inspector will issue violation reports, if necessary, with concurrence of the Signal inspector.

*37(e) Prevent railroad employees from visually inspecting moving equipment from their normal duty stations.*

**Guidance:** There are several ways in which vegetation can prevent railroad employees from visually inspecting moving equipment. For example, if vegetation is striking the window of the locomotive cab, that can interfere with a train crew's ability to observe rolling stock. Or, if vegetation is striking trains, that can interfere with ground employees' ability to observe the rolling stock during switching operations.

## Subpart C – Track Geometry

### § 213.51 Scope

*This subpart prescribes requirements for the gage, alinement, surface of track, and the elevation of outer rails and speed limitations for curved track*

**Guidance:** See the following figure for an illustration of basic track geometry concepts.

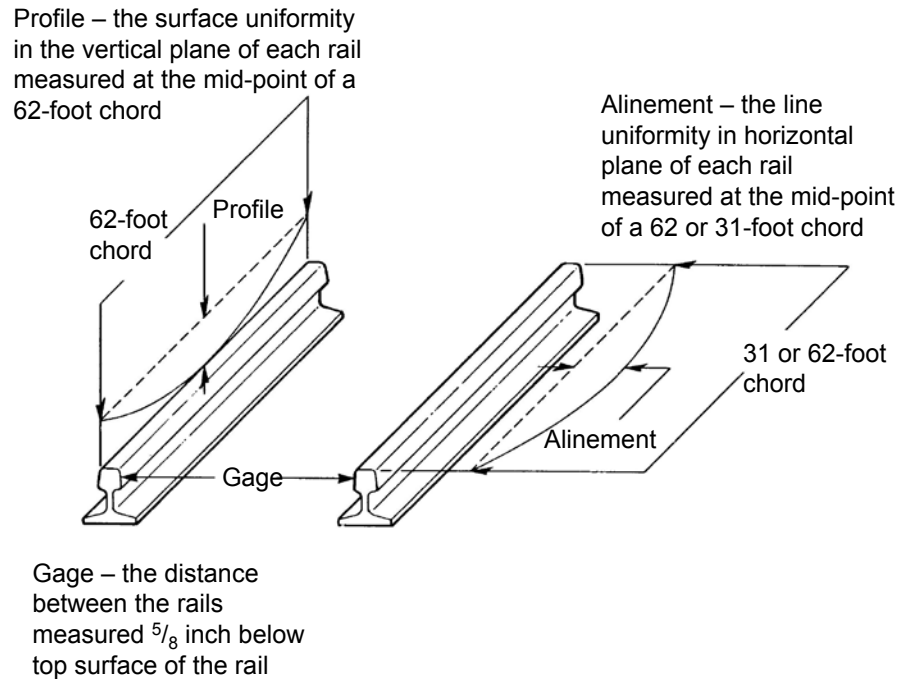

### § 213.53 Gage

*53(a) Gage is measured between the heads of the rails at right angles to the rails in a plane five-eighths of an inch below the top of the rail head.*

**Guidance:** See the following figure for an illustration of gage measurements.

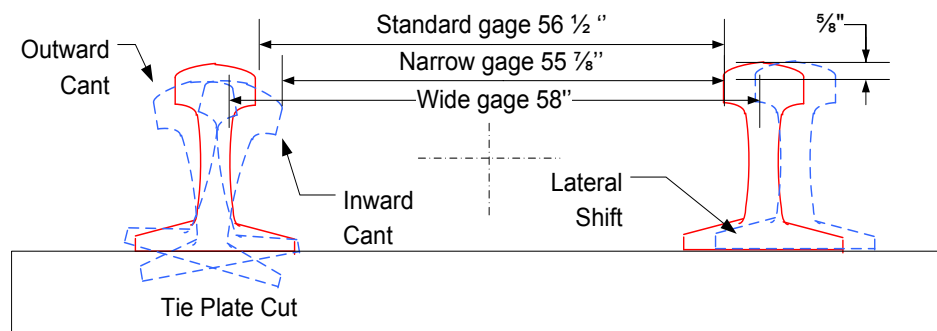

*53(b) Gage must be within the limits prescribed in the following table:*

<b><i>Class of Track</i></b>	<b><i>The gage must be at least -</i></b>	<b><i>But not more than -</i></b>
<i>Excepted track</i>	<i>N/A</i>	<i>4'10¼"</i>
<i>Class 1 track</i>	<i>4' 8"</i>	<i>4' 10"</i>
<i>Class 2 and 3 track</i>	<i>4' 8"</i>	<i>4' 9¾"</i>
<i>Class 4 and 5 track</i>	<i>4' 8"</i>	<i>4' 9½"</i>

**Guidance:** This rule establishes the minimum and maximum limits for gage on all tracks and differentiates with the authorized speed, including a maximum gage dimension of 4 feet 10¼ inches for track in excepted status under § 213.4.

Inspectors will make measurements at sufficient intervals to assure that track is being maintained within the prescribed limits. Particular attention should be given to track gage in turnouts or locations where high lateral train forces are expected or evident. These areas include the curved closure rails, the toe and heel of frogs, the curved track behind the frog and several feet ahead of the switch points.

Where line or surface irregularities are observed by the inspector, the gage should be measured. Remember to look for evidence of lateral rail movement as required in § 213.13.

An accurate standard track gage device or a rule graduated in inches is an acceptable measuring device. Gage not within the specified limits of the TSS is in noncompliance.

FRA inspectors may use a portable track loading fixture (PTLF) for the purposes of measuring loaded gage. Refer to Appendix D–PTLF, instructions for non-GRMS territory under § 213.53.

### **§ 213.55 Track alinement**

55(a) *Except as provided in paragraph (b) of this section, alinement may not deviate from uniformity more than the amount prescribed in the following table:*

<i>Class of Track</i>	<i>Tangent Track</i>	<i>Curved Track</i>	
	<i>The deviation of the mid-offset from a 62-foot line<sup>1</sup> may not be more than— (inches)</i>	<i>The deviation of the mid-ordinate from a 31-foot chord<sup>2</sup> may not be more than—(inches)</i>	<i>The deviation of the mid-ordinate from a 62-foot chord<sup>2</sup> may not be more than— (inches)</i>
<i>1</i>	<i>5</i>	<i>N/A<sup>3</sup></i>	<i>5</i>
<i>2</i>	<i>3</i>	<i>N/A<sup>3</sup></i>	<i>3</i>
<i>3</i>	<i>1¾</i>	<i>1¼</i>	<i>1¾</i>
<i>4</i>	<i>1½</i>	<i>1</i>	<i>1½</i>
<i>5</i>	<i>¾</i>	<i>½</i>	<i>⅝</i>

<sup>1</sup> The ends of the line must be at points on the gage side of the line rail, five-eighths of an inch below the top of the railhead. Either rail may be used as the line rail, however, the same rail shall be used for the full length of that tangential segment of track.

<sup>2</sup> The ends of the chord shall be at points on the gage side of the outer rail, five-eighths of an inch below the top of the railhead.

<sup>3</sup> N/A - Not Applicable.

**Guidance:** This paragraph establishes the maximum alinement deviations allowed for tangent and curved track in Classes 1 through 5 track.

Alinement is the variation in curvature of each rail of the track. On tangent track, the intended curvature is zero; thus, the alinement is measured as the variation or deviation from zero. In a curve, the alinement is measured as the variation or deviation from the “uniform” alinement over a specified distance. The inspector should note that the procedures for determining uniformity in Classes 6 through 9 are similar to the procedures described below. However, there are differences in the spacing of the stations and the application of the chord measurements.

The point of greatest alinement deviation usually can be detected visually or may be located by moving the chord along the track in increments until the point with maximum deviation is found. In curves, the mid-ordinate, alternatively called mid-chord offset (MCO), require “stations” to be marked at regular intervals on the high rail in both directions from the point in question. In tangent track, the MCO is measured directly with a 62-foot chord and graduated ruler. In curves, a 62-foot chord is used in Classes 1 through 5 and a 31-foot chord is also used in Classes 3 through 5. The term MCO is used interchangeably for “mid-ordinate” and “mid-offset” and represents the distance from the rail to the chord at the mid-point of the chord. For curves in Classes 3 through 5 track, an alinement defect may be in noncompliance with either the maximum limits for the 31-foot chord or the 62-foot chord, or both. A 31-foot chord is particularly necessary for determining short alinement deviations. Inspectors must be aware that a 62-foot chord may be “blind” to short alinement conditions, whereby a 31-foot chord can detect those noncomplying conditions. See the following figure.

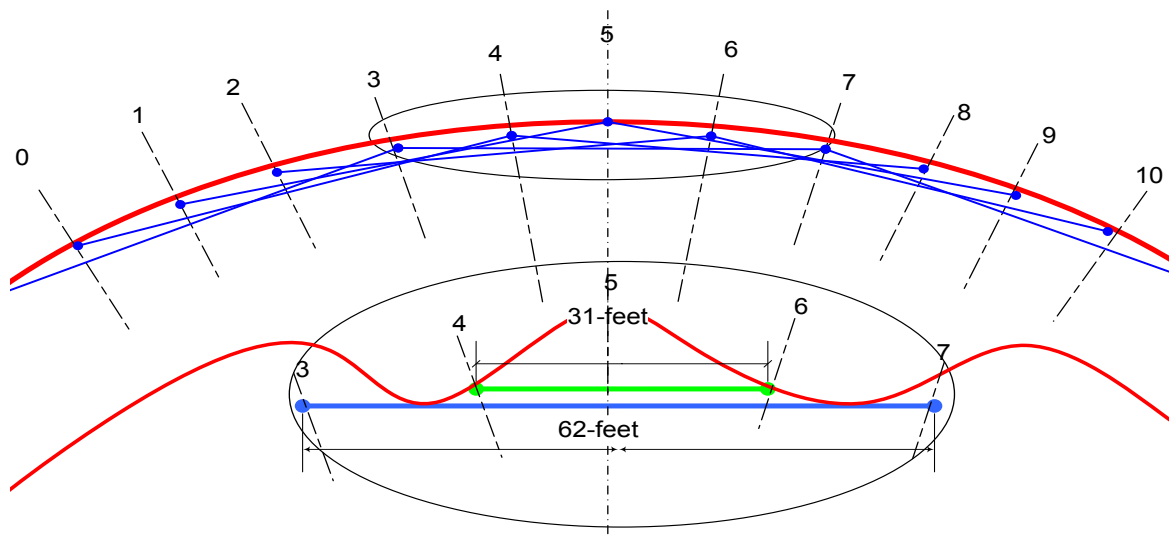

In Classes 3 through 5, both the 31-foot and 62-foot chords must be used, and corresponding measurements must be calculated to determine compliance with the required alignment thresholds. If alignment defects are found using both the 31-foot and the 62-foot chord, the inspector should report the item as one defect and note that the defect does not comply with the requirements for the second chord, e.g., “1¾ inches alignment deviation on curved track for 62-foot chord. Note: 1¾ inches alignment deviation for 31-foot chord at this location.”

The chord line (string) will be stretched and held taut between two points on the rail, five-eighths inch below the top running surface of the rail. Measure the MCO between the rail and the string with a graduated ruler, using blocks to compensate for shallow curvature and special trackwork, if necessary.

Since a true tangent has zero MCO, the measurement taken can be compared directly to the alignment table under § 213.55 to determine compliance. On a curve of constant curvature or each arc of a compound curve, mid-ordinates at all station points are equal when measured from chords of equal length, exclusive of spirals. MCOs, when measured from chords of equal length, are nearly proportional to the degree of curvature.

Degree of curvature is the angle subtended at the center of a simple curve by a 100-foot chord. Degree of curvature can be conveniently measured using either a 31- or a 62-foot chord. Obtaining the degree of curvature coupled with the average elevation in the area in question is necessary to determine maximum authorized speed. Please refer to § 213.57 for a discussion on the determination of curvature.

Deviation of alignment on a curve requires determination of the MCO over a specified number of stations and the average of those values. The difference between the MCO at the point of concern and the average must not exceed the maximum deviation specified in the table in § 213.55(a).

An optional method to determine average alignment includes 17 stations spaced at 15 feet 6 inches (see table below). For curves in Classes 3 through 5, it is necessary to determine compliance with the requirement for the maximum deviation of the MCO from a 31-foot chord in addition to the 62-foot chord. The following figure illustrates the method to determine alignment deviation using both chords.



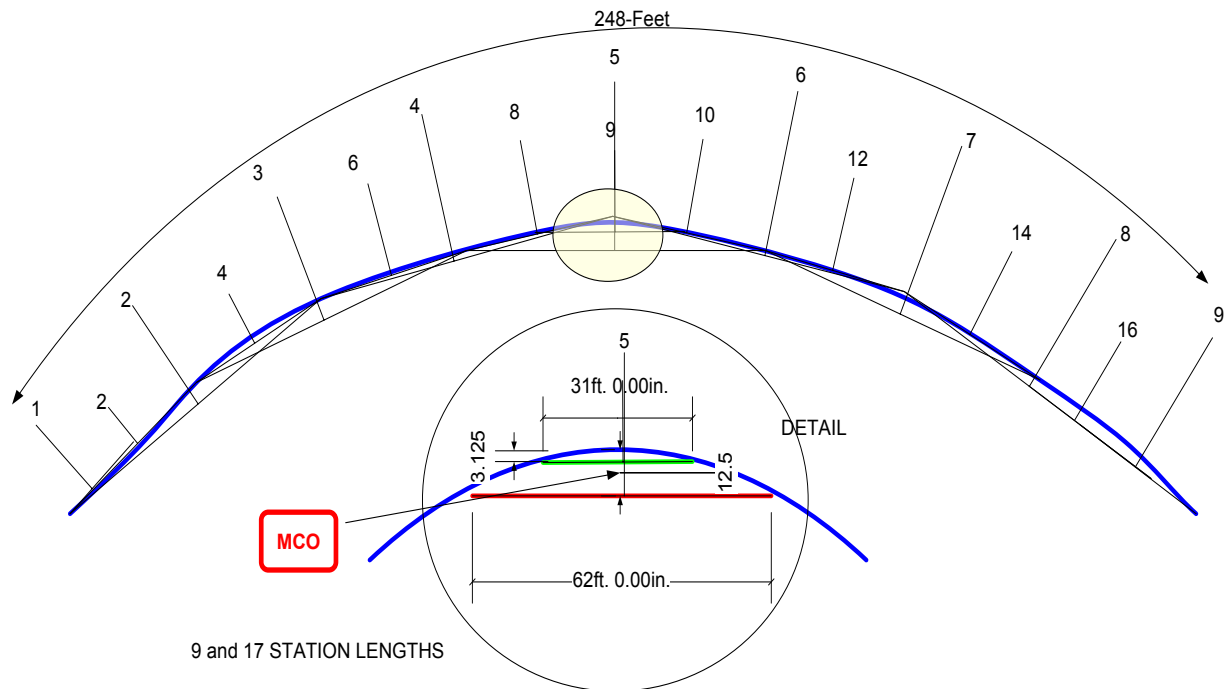

When using the above procedures, the distance between the first and last MCO will be 248 feet. However, note that in order to measure the MCO at the first and last stations, the inspector must place the end of the string a station beyond the first and last one measured. As a reference, the following table summarizes the acceptable proper chords, station spacing, and number of stations to determine alignment compliance.

Alignment Stations					
Geometry	Class	Chord (feet)	Total No. Stations	Station Spacing (feet)	Curve Length (feet)
Curve	1-2	62	9 or	31	248
		62	17	15½	248
	3-5	31	17	15½	248
		62	9 or	31	248
		62	17	15½	248
Tangent	1 - 5	62	1	n/a	n/a

As previously indicated, the suspected alinement location in a curve body is calculated by measuring an equal number of stations on each side of the area in question. For the majority of occurrences, averaging the MCOs on both sides of the location in question will develop sufficient data to determine “uniform alinement.” However, if the location in question is close to or in a spiral, uniformity must be determined in a different manner. If the location is located at the portion of a curve body close to a spiral, measure the stations in the curve body only. That is, shift the averaging area sufficiently so that none of the MCOs are in the spiral.

When measuring the body of a curve with a length that is less than the distance spanned by the required number of stations, reduce the numbers of stations accordingly. When measuring a compound curve, it will be necessary to measure the MCOs within a sufficient portion of the entire curve to determine where the curve bodies exist. Treat each curve body as a separate curve and be governed by the above instructions.

Over the years, railroads have traditionally used a 31-foot chord to determine MCOs for higher degree curves. Although it is more difficult to measure from the rail to the MCO at high degree curves, the inspector must determine alignment compliance in accordance with both the 62 and 31-foot chords described in this section.

In spirals, the alignment gradually changes from tangent to the full degree of curvature at the curve body. The projected MCO values must be established, which is a function of actual curvature at a specific point on the spiral, curvature (of the curve body) and spiral length. The first step is to determine the tangent to spiral (TS) and spiral to curve (SC). There are several ways to determine TS and SC. An inspector can reference geometry car measurements, if available. Alternatively, he/she can measure alignment MCOs along the entire spiral length, ensuring a sufficient distance into the adjoining curve body and tangent track to accurately locate TS and SC.

Once TS and SC are determined and marked, the actual curvature at any point on the spiral can be easily calculated with known curvature of the curve body and spiral length - the distance between TS and SC. For example, at a point 100 ft from TS on a spiral, the curvature is

$$D_i = D \times \frac{100}{L_s}$$

Where

$D_i$  = the actual curvature at the  $i^{\text{th}}$  point on the spiral, *degrees*

$D$  = curvature of the curve, *degrees*,

$L_s$  = spiral length, *ft*

With known spiral curvature, the 31-ft or 62-ft MCOs can be projected based on curvature-to-MCO extrapolation (e.g. 1 degree curvature yields approximately 1" 62-ft MCO or ¼" 31-ft MCO).

Plot the measured values along with projected values in a graph or construct a table of the measured and projected values. The deviation at the point of concern will be the difference between the measured and the projected MCO values. Use the curve values from the alignment table to determine compliance in spirals.

The following figure represents a hypothetically case where the spiral length is 248 ft. (9 stations spaced at 31 ft). The chart would approximate a 1.44 degree curve whose curvature is gradually increased from 0 (at TS) to 1.44 degrees (at SC). The figure shows a spiral calculation for 62-foot chord with MCO units in  $1/16$ -inch increments. A similar analysis is required for 31-foot chord for Classes 3 through 5. At Station 5, the measured value is 18 units ( $1\frac{1}{8}$  inches) and the projected value is 12 units ( $\frac{3}{4}$  inch); therefore, the deviation from uniformity is 6 units ( $\frac{3}{8}$  inch).

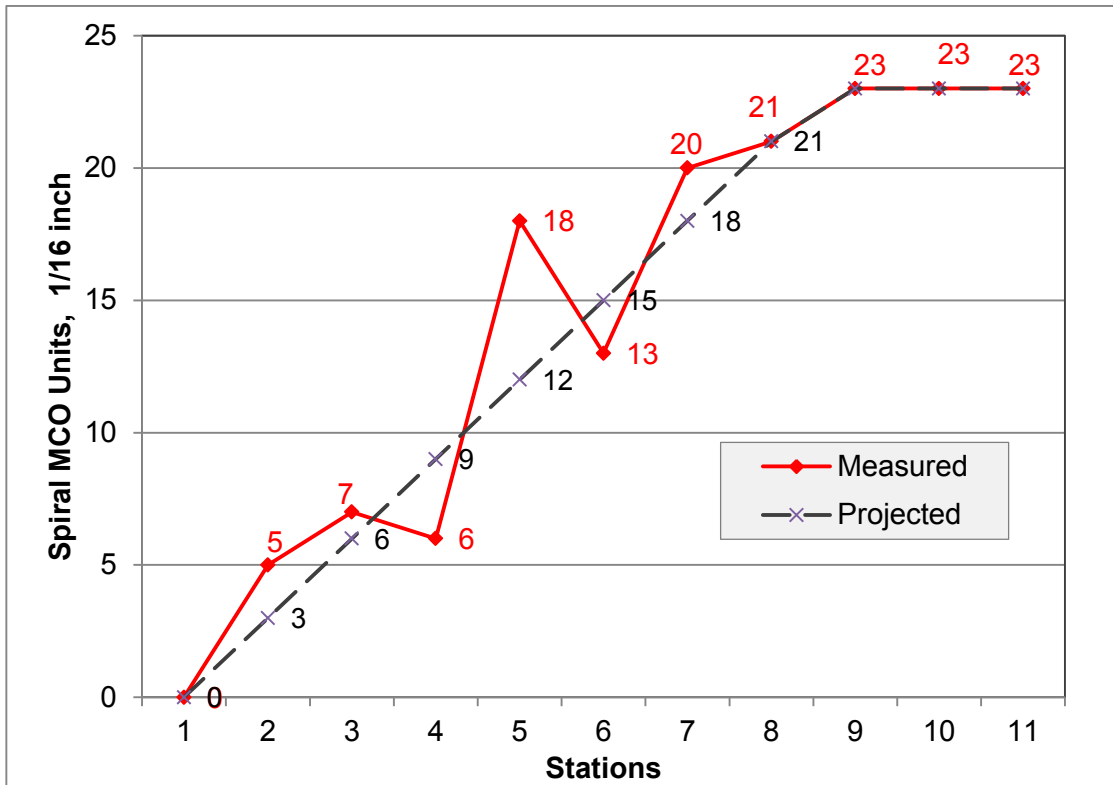

For long spirals, especially in higher speed curves, it could become arduous to measure the entire spiral. Where it's feasible to determine the approximate locations of TS and SC, the inspector can opt to measure several stations (no more than 6 for either TS or SC) around the two pre-identified areas to pinpoint TS and SC to determine the spiral length. The inspector can then calculate the actual spiral curvature using the equation shown above. This actual spiral curvature is then extrapolated into projected/alineament MCO (1 degree to 1" 62-ft MCO or ¼" 31-ft MCO). The inspector can take one single MCO measurement at the point of concern to determine compliance. The difference between the projected and measured alineament will be used to assess compliance, referencing the allowable values from the alineament table.

55(b) For operations at a qualified cant deficiency,  $E_u$ , of more than 5 inches, the alineament of the outside rail of the curve may not deviate from uniformity more than the amount prescribed in the following table:

Class of track	Curved track	
	The deviation of the mid-ordinate from a 31-foot chord <sup>1</sup> may not be more than—(inches)	The deviation of the mid-ordinate from a 62-foot chord <sup>1</sup> may not be more than—(inches)
Class 1 track <sup>2</sup>	<sup>3</sup> N/A	1 ¼
Class 2 track <sup>2</sup>	<sup>3</sup> N/A	1 ¼
Class 3 track	¾	1 ¼
Class 4 track	¾	⅞

Class 5 track	$\frac{1}{2}$	$\frac{5}{8}$
<sup>1</sup> The ends of the chord shall be at points on the gage side of the outer rail, five-eighths of an inch below the top of the railhead. <sup>2</sup> Restraining rails or other systems may be required for derailment prevention. <sup>3</sup> N/A—Not Applicable		

**Guidance:** The guidance for paragraph 55(a) also applies to this paragraph. However, the limits in the table of this paragraph apply only to operations at a qualified cant deficiency of more than 5 inches, and to outside rail of the curve. Note that the limits for Class 4 and lower track have been tightened – most notably for Class 1 and 2 track 62-ft MCO. These limits were established based on computer simulations to provide sufficient margins of safety, as higher cant deficiency operations will result in higher lateral wheel loads.

As for any operation involving more than 5 inches of cant deficiency, the track owner or railroad must have the necessary FRA approval/documentation showing that the operations are qualified for a cant deficiency higher than 5 inches.

If the track owner or railroad, in response to an alignment exception to table 55(b), has posted a speed restriction which no longer corresponds to a cant deficiency of more than 5 inches, the inspector should use the limits in table 55(a) to assess alignment compliance.

### § 213.57 Curves; elevation and speed limitations

57(a) *The maximum elevation of the outside rail of a curve may not be more than 8 inches on track Classes 1 and 2, and 7 inches on track Classes 3 through 5. The outside rail of a curve may not be lower than the inside rail by design, except when engineered to address specific track or operating conditions; the limits in §213.63 apply in all cases.*

**Guidance:** The term “elevation of the outside rail” is relevant to the inside rail. In literature and in practice, it is also referred as superelevation. This paragraph does not imply that more than 6 inches of superelevation is recommended in a curve; rather the paragraph limits the amount of superelevation in a curve to control the unloading of the wheels on the outer rail, especially at low speeds. The limits establish the maximum superelevation at any point on the curve; which may not be more than 8 inches on Classes 1 and 2, and 7 inches on Classes 3 through 5. In curves, superelevation is measured by subtracting the relative difference in height between the top surface (tread) of the inside (low) rail from the tread of the outside (high) rail. Both this section and § 213.63 limit the amount of reverse elevation (outside rail lower than the inside rail). While the table in § 213.63 permits reverse elevation on a curve, the  $V_{\max}$  formula must also be checked when reverse elevation is encountered. The inspector must substitute a negative number for the actual elevation in the formula as discussed below. The  $V_{\max}$  formula applies only in the body of a curve.

The phrase “except when engineered to address specific track or operating conditions” is intended to address special cases, such as a turnout that comes off the high rail in a curve, to allow reverse elevation to be designed into the curve out of necessity and for safety reasons.

57(b) *The maximum allowable posted timetable operating speed for each curve is determined by the following formula –*

$$V_{max} = \sqrt{\frac{E_a + E_u}{0.0007D}}$$

*Where:*

$V_{max}$  = Maximum allowable posted timetable operating speed (m.p.h.).

$E_a$  = Actual elevation of the outside rail (inches).<sup>1</sup>

$E_u$  = Qualified cant deficiency<sup>2</sup> (inches) of the vehicle type.

$D$  = Degree of curvature (degrees).<sup>3</sup>

<sup>1</sup> Actual elevation,  $E_a$ , for each 15-foot track segment in the body of the curve is determined by averaging the elevation for 11 points through the segment at 15.5-foot spacing. If the curve length is less than 155 feet, the points are averaged through the full length of the body of the curve.

<sup>2</sup> If the actual elevation,  $E_a$ , and degree of curvature,  $D$ , change as a result of track degradation, then the actual cant deficiency for the maximum allowable posted timetable operating speed,  $V_{max}$ , may be greater than the qualified cant deficiency,  $E_u$ . This actual cant deficiency for each curve may not exceed the qualified cant deficiency,  $E_u$ , plus 1 inch.

<sup>3</sup> Degree of curvature,  $D$ , is determined by averaging the degree of curvature over the same track segment as the elevation.

**Guidance:** Paragraph (b) prescribes the formula to be used to determine the maximum train speed in curves based on average curve alinement in degrees, qualified cant deficiency, and the amount of superelevation at the same location.

A railroad car traveling around a curve is subjected to an outward horizontal centrifugal force that acts conceptually through a car's center of gravity away from the center of the curve and tends to overturn the car by directing its weight toward the outside rail. To counteract the centrifugal force, the outer rail is elevated over the lower rail, or superelevated. In effect, the combined effect of centrifugal force and weight produces a resultant force that is intentionally moved toward the center of the track. A balanced (equilibrium) condition implies the vertical forces on each rail are equal. The following figure illustrates three scenarios for the given curvature and superelevation. The chart in the center indicates that if the vehicle is traveling at 42 m.ph., the equilibrium will be achieved. The chart on the left is an overbalanced scenario, in which a net inward acceleration (weight shifting to low rail) will result as the vehicle travels slower than 42 m.p.h. The chart on the right represents an underbalanced scenario, in which a net outward acceleration (weight shifting to high rail) will result as the vehicle travels faster than 42 m.p.h. Using the  $v_{Max}$  formula in this example, 3 inches of unbalance allows a maximum posted timetable speed of speed of 54 mph. Tolerance for localized degradation of up to 1 inch ( $E_u+1$ ) results in a maximum speed of 57 mph. (§213.57(a) would apply to overbalance)

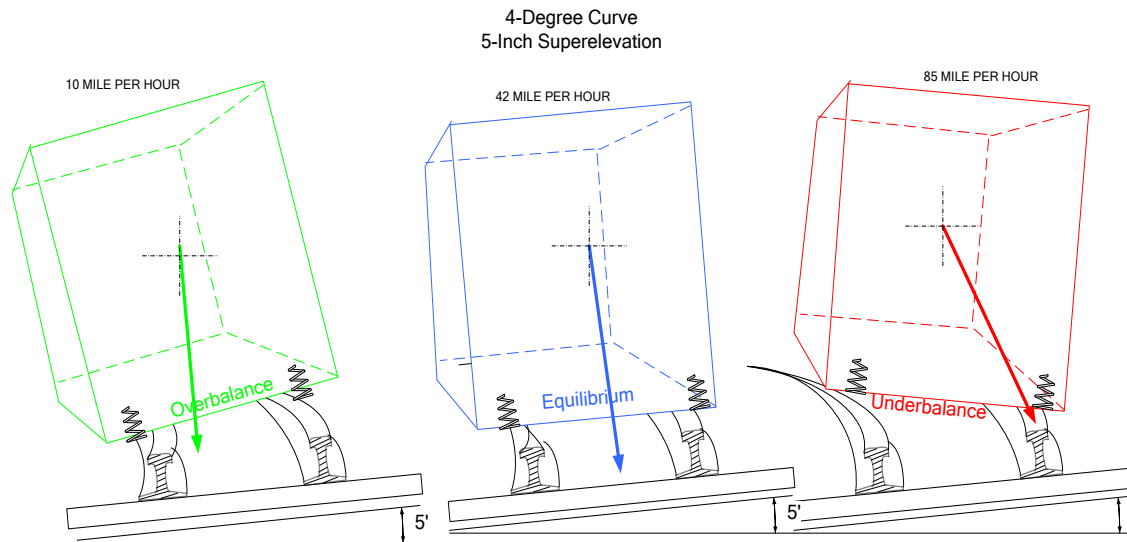

In practice, railroads generally do not operate trains at balanced speed; that is, train speeds are set to move the resultant force toward the outer rail, resulting in an unbalance, typically less than 3 inches. Unbalance, also commonly referred to as cant deficiency, is the theoretical amount of elevation that would have to be added to the existing elevation to achieve a balanced condition. The TSS for Classes 1 through 5 limits the amount of unbalance to 3 inches, except that higher unbalance is permitted for authorized and approved equipment types. Appropriate vehicle/track system qualification tests will apply to operations at cant deficiencies higher than 3 inches.

Safe curving speeds are dependent on the engineering characteristics of the specific equipment involved, as well as the track conditions. Equipment factors, such as center of gravity, suspension characteristics, and reaction to wind and other factors, are considered when FRA makes a decision to approve a particular level of cant deficiency for specified equipment.

Track inspectors can use the formula to assess compliance in two ways:

- 1) Calculating cant deficiency by inserting the posted timetable speed, actual superelevation ( $E_a$ ), and curvature ( $D$ ) at the time of inspection. If the resulting actual cant deficiency is higher than the qualified cant deficiency, there is a potential limiting speed defect.
- 2) Calculating maximum allowable operating speed by inserting the actual elevation ( $E_a$ ), and curvature ( $D$ ) at the time of inspection and qualified cant deficiency ( $E_u$ ). If the resulting speed is lower than the posted timetable speed, there is a potential limiting speed defect.

Footnote 1 clarifies the procedure to establish the actual elevation  $E_a$  which states that 11 points at 15.5-foot spacing through the 155-foot evaluation segment will be averaged. In calculating elevation, 10 measurements are taken in addition to the point of concern — 5 on each side—so that a total of 11 points are actually averaged.

The method of 11-point average over 155-foot segment at 15.5-foot station spacing applies to both 31- and 62-foot chords and to the curve body only. If a curve's length is less than

155 feet, the measurements are averaged over the full length of the curve. In order to determine the average curvature, inspectors must calculate the degree of curvature based on the chord length used (either 31 or 62 feet) and the MCO measured at each station. For a 31-foot chord, the degree of curvature is determined by multiplying the MCO by a factor of four (e.g., one-quarter inch equals 1 degree). For a 62-foot chord, a one-to-one relationship exists (e.g., 1 inch equals 1 degree).

Footnote 2 permits the vehicle type to operate at the approved cant deficiency plus 1 inch, if the actual elevation,  $E_a$ , and the degree of track curvature,  $D$ , have changed as a result of track degradation. The note is intended to provide a tolerance to account for the effects of local superelevation or curvature conditions on  $V_{max}$  that may result in the actual cant deficiency exceeding the approved level for the equipment. The intent is to allow this tolerance for “local crosslevel or curvature conditions” that result in track degradation below the maintenance limits of the track owner/railroad. The footnote is not intended to provide a tolerance to be factored into the maintenance limits themselves. For example, if the “maximum allowable posted timetable operating speed” is based on a  $V_{max}$  corresponding to 3 inches of cant deficiency, the track owner/railroad should not establish maintenance practices that are intended to result in operation of equipment at a speed that produces up to 4 inches of cant deficiency. Yet in this example, should the equipment actually operate at a speed that produces over 3 inches of cant deficiency due to track degrading below the intended maintenance limits of the track owner/railroad, the track owner/railroad should not be penalized merely because the cant deficiency exceeds 3 inches.

Caution need to be paid when exercising this provision. Because a tolerance is now part of the regulation, not all exceedances are actual defects (i.e., actual instances of non-compliance). The Inspector should only record the condition as a defect if there is evidence that the maintenance practices of the track owner/railroad created a condition where the actual amount of cant deficiency exceeded the approved value. In this case FRA expects the track owner/railroad to take appropriate remedial action. The Inspector should consider writing a recommendation for civil penalty if the level of cant deficiency based on the maximum speed, elevation, and curvature exceeds the approved value,  $E_u$ , by more than 1 inch. When the actual cant deficiency is found to exceed the approved level, there are many scenarios that could involve compliance or non-compliance with the regulation, and all of these different scenarios cannot be easily described here. The Inspector should consider multiple factors when determining whether to assess a defect or recommend a violation. For example, if the Inspector can establish that a track has been recently machine-tamped and that it was not possible for the track to have degraded to the level of causing an exceedance of the approved cant deficiency in the time period after the tamping, the Inspector may assess a defect. In another example, if the track owner/railroad voluntarily performs spot maintenance on a curve, typically through spot-tamping, to bring the curve to uniformity (in terms of curvature and elevation), and the amount of cant deficiency still exceeds the approved level by a nominal amount, the Inspector should exercise his or her discretion whether to assess a defect. The Inspector should consider assessing a defect when the exceedance is close to the maximum tolerance, which leaves little room for further track degradation. In all cases, if the Inspector cannot determine whether a condition is out of compliance, or whether to assess a defect or recommend a civil penalty, he or she should consult with the Regional Track Specialist.

In addition to the limitations on reverse elevation contained in the table in § 213.63, the  $V_{max}$  formula limits the maximum authorized speed on a curve. Reverse elevation occurs when the inside rail is higher than the outside rail; that is usually the unintended consequence of track degradation. The condition can also occur where a turnout has been installed in a

main track (e.g., an equilateral turnout constructed in a left-hand curve). Calculation of the maximum authorized speed for the curve with negative elevation is performed in the same manner as one with positive elevation. For example, the maximum authorized speed is approximately 13 mph for a curve segment with an average curvature of 4 degrees and 2½ inches of reverse elevation (both calculated over the 155 foot window or the length of the curve), the calculation for 3 inches of unbalance would be as shown below:

$$V_{\max} = \sqrt{\frac{E_a + E_u}{0.0007D}} = \sqrt{\frac{-2.5 + 3}{0.0007 \times 4}} = 13 \text{ mph}$$

*57(c) All vehicles are considered qualified for operating on track with a cant deficiency,  $E_u$ , not exceeding 3 inches. Table 1 of appendix A to this part gives the speeds computed in accordance with the formula in paragraph 57(b), when  $E_u$  equals 3 inches, for various elevations and degrees of curvature.*

**Guidance:** This paragraph provides that all vehicle types are considered qualified for up to 3 inches of cant deficiency.

*57(d) Each vehicle type must be approved by FRA to operate on track with a qualified cant deficiency,  $E_u$ , greater than 3 inches. Each vehicle type must demonstrate, in a ready-for-service load condition, compliance with the requirements of either paragraph (d)(1) or (2) of this section.*

- (1) When positioned on a track with a uniform four inch superelevation equal to the proposed cant deficiency:*
  - (i) No wheel of the vehicle type unloads to a value less than 60 percent of its static value on perfectly level track; and*
  - (ii) For passenger cars, the roll angle between the floor of the equipment and the horizontal does not exceed 8.6 degrees; or*
- (2) When operating through a constant radius curve at a constant speed corresponding to the proposed cant deficiency, and a test plan is submitted to and approved by FRA in accordance with §213.345(e) and (f):*
  - (i) The steady-state (average) load on any wheel, throughout the body of the curve, is not less than 60 percent of its static value on perfectly level track; and*
  - (ii) For passenger cars, the steady-state (average) lateral acceleration measured on the floor of the carbody does not exceed 0.15g.*

**Guidance:** The rule does not limit maximum level of cant deficiency in track Classes 1 through 5. However, the equipment must satisfy the requirements of this section. Consistent with the higher-speed standards in § 213.329, the requirements limit (1) vertical wheel load remaining on the raised wheels to no less than 60 percent of their static level values and (2) carbody roll for passenger cars to no more than 8.6 degrees with respect to the horizontal when the vehicle is standing (stationary) on track with a uniform superelevation equal to the proposed cant deficiency. The amount of superelevation will be the proposed cant deficiency. For example, if the proposed cant deficiency is 5 inches, the superelevation used for demonstrating compliance with this paragraph is also 5 inches.



The requirements in paragraph (d) may be met by either static or dynamic testing. The static lean test limits the vertical wheel load remaining on the raised wheels and the roll of a passenger carbody with respect to the horizontal plane to the thresholds mentioned above. The dynamic test limits the steady-state vertical wheel load remaining on the low rail wheels to no less than 60 percent of their static level values and limits the lateral acceleration in a passenger car to 0.15g steady-state, when the vehicle operates through a curve at the proposed cant deficiency. This 0.15g steady-state lateral acceleration limit in the dynamic test is intended to provide consistency with the 8.6-degree roll limit in the static lean test, which corresponds to the lateral acceleration a passenger would experience in a standing vehicle with its carbody rolled 8.6 degrees with respect to the horizontal.

Measurements and supplemental research have indicated that a steady-state, carbody lateral acceleration limit of 0.15g is considered to be the maximum, steady-state lateral acceleration above which jolts from vehicle dynamic response to track deviations can present a hazard to passenger safety. While other FRA vehicle/track interaction safety criteria principally address external safety hazards that may cause a derailment, such as damage to track structure and other conditions at the wheel/rail interface, the steady-state, carbody lateral acceleration limit specifically addresses the safety of the interior occupant environment. This steady-state, carbody lateral acceleration will result in a lateral force, pulling passengers to one side of the carbody. It is not the same as sustained, carbody lateral oscillatory accelerations, or continuous side-to-side oscillations (hunting) of the carbody in response to track conditions, which could exist on both curved and tangent track.

*57(e) The track owner or railroad shall transmit the results of the testing specified in paragraph (d) of this section to FRA's Associate Administrator for Railroad Safety/Chief Safety Officer (FRA) requesting approval for the vehicle type to operate at the desired curving speeds allowed under the formula in paragraph (b) of this section. The request shall be made in writing and contain, at a minimum, the following information—*

- (1) A description of the vehicle type involved, including schematic diagrams of the suspension system(s) and the estimated location of the center of gravity above top of rail;*
- (2) The test procedure<sup>4</sup> including the load condition under which the testing was performed, and description of the instrumentation used to qualify the vehicle type, as well as the maximum values for wheel unloading and roll angles or accelerations that were observed during testing; and*
- (3) For vehicle types not subject to parts 229 or 238 of this chapter, procedures or standards in effect that relate to the maintenance of all safety-critical components of the suspension system(s) for the particular vehicle type. Safety-critical components of the suspension system are those that impact or have significant influence on the roll of the carbody and the distribution of weight on the wheels.*

**Guidance:** This paragraph clarifies the submittal requirements to FRA to obtain approval for the qualifying cant deficiency of a vehicle type. The load condition under which the testing is performed is required to be included in the description of the test procedure. The paragraph also includes the requirement for submitting suspension

---

<sup>4</sup> The test procedure may be conducted whereby all the wheels on one side (right or left) of the vehicle are raised to the proposed cant deficiency, the vertical wheel loads under each wheel are measured, and a level is used to record the angle through which the floor of the vehicle has been rotated.

system maintenance information.

For vehicle types not subject to 49 CFR parts 238 or 229, such as a freight car operated in a freight train, the requirement for submitting suspension system maintenance information only to safety-critical components.

Footnote 4 specifies more detailed requirements if the cant deficiency requirement of 57(d)(1) is satisfied through static lean test.

*57(f) In approving the request made pursuant to paragraph (e) of this section, FRA may impose conditions necessary for safely operating at the higher curving speeds. Upon FRA approval of the request, the track owner or railroad shall notify FRA in writing no less than 30 calendar days prior to the proposed implementation of the approved higher curving speeds allowed under the formula in paragraph (b) of this section. The notification shall contain, at a minimum, identification of the track segment(s) on which the higher curving speeds are to be implemented.*

**Guidance:** The paragraph requires that a track owner/railroad notify FRA prior to the implementation of the approved higher curving speeds. The paragraph also clarifies that in approving the request made pursuant to paragraph (e), FRA may impose conditions necessary for safely operating at the higher curving speeds.

Where FRA has approved higher levels of unbalance, it becomes imperative that the inspector monitor the maximum authorized speeds based on the approved unbalance. The calculation of the maximum authorized speed for a particular segment of track involves the substitution of the approved unbalance in the  $V_{\max}$  formula. For example, if FRA approved 5 inches of cant deficiency for a particular type of equipment, the maximum curving speed for a 6-degree curve segment with 4½ inches of elevation would be calculated as follows:

$$V_{\max} = \sqrt{\frac{E_a + E_u}{0.0007D}} = \sqrt{\frac{4.5 + 5}{0.0007 \times 6}} = 47 \text{ m.p.h.}$$

To determine an enforcement action, it is also necessary for the inspector to determine the actual unbalance based on the speed that the railroad is operating around the curve and the actual track conditions. In order to calculate the unbalance, the inspector must solve the following formula, which is the same  $V_{\max}$  formula represented in a different form:

$$E_u = 0.0007 \cdot D \cdot V_{\max}^2 - E_a$$

For example, if the railroad was operating around a curve at 89 m.p.h. and the inspector determined, by field measurements, that the average curvature and average elevation for a particular curve segment were 2¼ degrees and 5½ inches, respectively. The unbalance would be calculated as follows:

$$E_u = 0.0007 \cdot D \cdot V_{\max}^2 - E_a = 0.0007 \times 2.25 \times 89^2 - 5.5 = 6.9 \text{ inch}$$

In this example, the operating speed has resulted in a cant deficiency of 6.9 inches, which is 1.9 inches over the approved level of 5 inches. As mentioned in the guidance for 57(b), the inspector should consider a recommendation for civil penalty. When vehicle types have been approved by FRA for curving speeds producing more than the approved level but not exceeding by more than 1 inch, inspectors may consider writing a defect according to the guidance in 57(b).

The following figure illustrates the relationship between curvature, elevation, and speed.

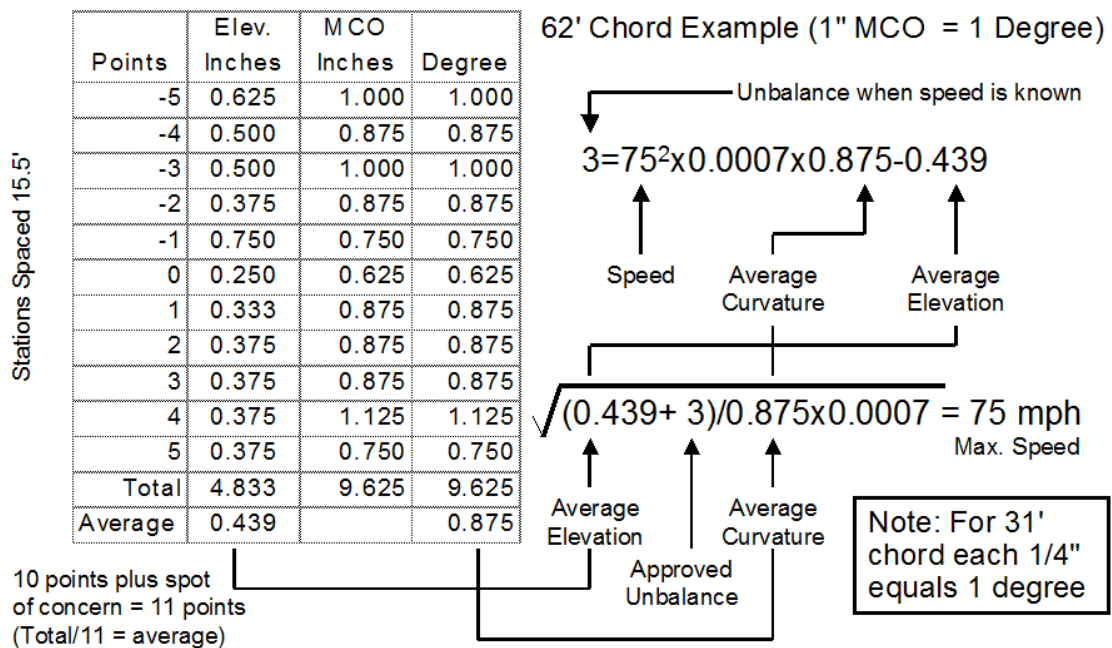

57(g) The documents required by this section must be provided to FRA by:

- (1) The track owner; or
- (2) A railroad that provides service with the same vehicle type over trackage of one or more track owner(s), with the written consent of each affected track owner.

**Guidance:** This paragraph states that either a track owner or a railroad (operator), e.g. Amtrak or other commuter railroads, providing services over trackage of more than one track owner with the same vehicle type may provide the required documents to the FRA. However, the operator must have consent of each track owner.

By allowing the operator to submit the documents, FRA eliminates the potential of multiple submissions for the same vehicle type.

This paragraph is identical to two other provisions in § 213.329(g) - the subpart G counterpart to this section - and § 213.345(i).

- 57(h) (1) Vehicle types permitted by FRA to operate at cant deficiencies,  $E_u$ , greater than 3 inches but not more than 5 inches shall be considered qualified under this section to operate at those permitted cant deficiencies on any track segment. The track owner or railroad shall notify FRA in writing no less than 30 calendar days prior to the proposed implementation of such curving speeds in accordance with paragraph (f) of this section.
- (2) Vehicle types permitted by FRA to operate at cant deficiencies,  $E_u$ , greater than 5 inches shall be considered qualified under this section to operate at those permitted cant deficiencies only for the previously operated or identified track segment(s).

**Guidance:** This paragraph concerns vehicle types that have been previously permitted by FRA to operate at cant deficiencies,  $E_u$ , greater than 3 inches.

Paragraph (h)(1) states these vehicle types previously approved by FRA to operate at cant deficiencies,  $E_u$ , between 3 and 5 inches are considered qualified under this section to operate at the approved cant deficiencies on any track segment. The rationale to allow this portability is that the requirements of this section are steady-state and do not directly reflect the “local” vehicle and the track interaction.

Nonetheless, a provision in paragraph (h)(1) required that written notice be provided to FRA no less than 30 calendar days prior to the proposed implementation of such curving speeds on another track segment in accordance with paragraph (f) of this section. This notice is intended to identify the new track segment(s) so that FRA is aware of the proposed operation to ensure that appropriate permission has been provided for it, and for administering the requirements of this rule.

However, the provision in paragraph (h)(2) restricts the “portability” of cant deficiency qualification for vehicle types that have been permitted by FRA to operate at cant deficiencies,  $E_u$ , greater than 5 inches. Operation at cant deficiencies greater than 5 inches over other track segments must be newly qualified in accordance with this rule, consistent with the additional requirements for the safety of operations at cant deficiencies greater than 5 inches.

*57(i) For vehicle types intended to operate at any curving speed producing more than 5 inches of cant deficiency, the following provisions of subpart G of this part shall apply: §§ 213.333(a) through (g), (j)(1), (k) and (m), 213.345, and 213.369(f).*

**Guidance:** The paragraph applies to operations at cant deficiencies greater than 5 inches. The requirements for operations of more than 5 inches cant deficiency apply to all classes of track. These requirements are specified in §§ 213.333, Automated vehicle-based inspection systems, paragraphs (a) through (g), (j)(1), (k) and (m); 213.345, Vehicle/track system qualification; and 213.369, Inspection records, paragraph (f). These requirements are briefly summarized below. For complete guidance on § 213.333 and other provisions of subpart G please see Volume II, Chapter 2 of this manual.

Section 213.333(a)(1) requires a Track Geometry Measurement System (TGMS) to be operated over Class 1 through 5 track that supports cant deficiency operations of more than 5 inches. The frequency for the TGMS inspections is at least twice per calendar year with not less than 120 days between inspections. Sections 213.333(b) through (e) list the TGMS system criteria. Section 213.333(f) continues to require that the track owner, within two days after the TGMS inspection, field verify and institute remedial action for all exceptions to the class of track. Section 213.333(g) requires the track owner or railroad to maintain a copy of the plot and the exception report for the required TGMS inspection. Section 213.333(j)(1) requires that a vehicle having dynamic response characteristics representative of other vehicles assigned to the service be operated over the route at the revenue speed profile. The vehicle shall be monitored for carbody accelerations with an onboard monitoring system at least once each calendar quarter. Section 213.333(k) describes the requirements for monitoring carbody lateral and vertical accelerations and track frame lateral acceleration. Section 213.333(m) requires the track owner or railroad to maintain a copy of the most recent exception records for the inspections required under paragraphs 333(j), (k).and (l).

57(j) *As used in this section—*

- (1) *Vehicle means a locomotive, as defined in § 229.5 of this chapter; a freight car, as defined in § 215.5 of this chapter; a passenger car, as defined in § 238.5 of this chapter; and any rail rolling equipment used in a train with either a freight car or a passenger car.*
- (2) *Vehicle type means like vehicles with variations in their physical properties, such as suspension, mass, interior arrangements, and dimensions that do not result in significant changes to their dynamic characteristics.*

**Guidance:** Paragraph (j) clarifies “vehicle” and “vehicle type.” The paragraph is of particular importance when determining if a vehicle type is subject to the qualification requirements of this section. For example, a vehicle type with modified primary springs to improve performance at different speeds may be considered a new vehicle type and hence subject to the qualification requirements of this section.

### **§ 213.59 Elevation of curved track; (runoff)**

*59(a) If a curve is elevated, the full elevation must be provided throughout the curve, unless physical conditions do not permit. If elevation runoff occurs in a curve, the actual minimum elevation shall be used in computing the maximum allowable posted timetable operating speed for that curve under § 213.57(b).*

**Guidance:** When determining whether curved track is in compliance with the TSS, inspectors should consider §§ 213.57, 213.59, and 213.63 in conjunction with one another. Because the language in § 213.59 is explanatory in nature and intertwined with the requirements in §§ 213.57 and 213.63, this section should not stand alone in support of an alleged violation. FRA Inspectors should cite either § 213.57 or § 213.63, whichever is most applicable.

*59(b) Elevation runoff shall be at a uniform rate, within the limits of track surface deviation prescribed in §213.63, and it shall extend at least the full length of the spirals. If physical conditions do not permit a spiral long enough to accommodate the minimum length of runoff, part of the runoff may be on tangent track.*

**Guidance:** Items to consider with respect to runoff include the following:

- If elevation begins within the body of the curve rather than at the point of curve-spiral, the least average elevation that exists in the body of the curve will govern the allowable operating maximum speed throughout the full curve.
- Elevation at the end of curves, or between segments of compound curves, must be at a uniform rate within the limits of track surface deviations prescribed in the table under § 213.63.
- Particular attention must be given to the prescribed limits for difference in crosslevel between any two points less than 62 feet apart on spirals.
- If physical conditions do not permit a spiral long enough to accommodate the minimum length of runoff, the runoff may be carried into the tangent. In these circumstances, the surface table parameters under § 213.63 will govern.

- The actual minimum elevation and actual degree of curvature is determined by using the averaging techniques described under § 213.57.

The following figure illustrates how a railroad can reduce superelevation in the body of the curve to accommodate a highway-rail grade crossing for unqualified equipment (3 inches unbalance).

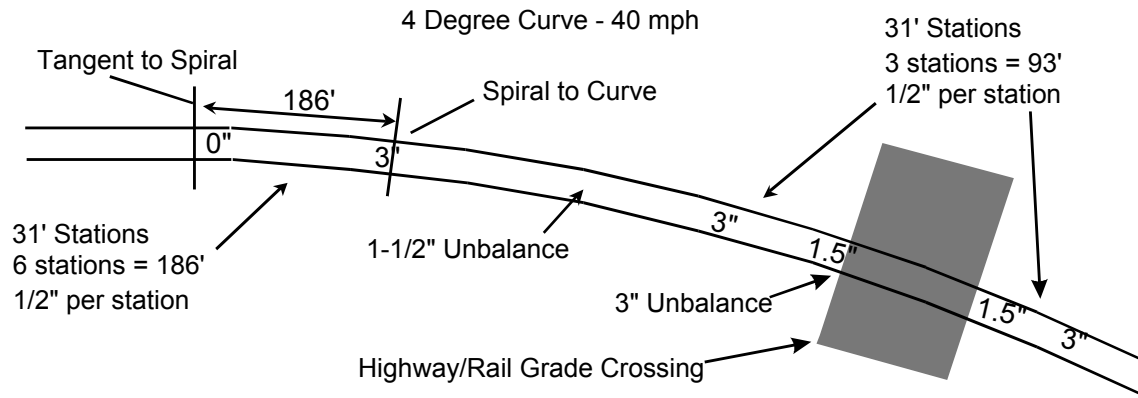

**§ 213.63 Track Surface**

63(a) Except as provided in paragraph (b) of this section, each track owner shall maintain the surface of its track within the limits prescribed in the following table:

Track surface (inches)	Class of track				
	1	2	3	4	5
The runoff in any 31 feet of rail at the end of a raise may not be more than .....	3½	3	2	1½	1
The deviation from uniform profile on either rail at the mid-ordinate of a 62-foot chord may not be more than ...	3	2¾	2¼	2	1¼
The deviation from zero crosslevel at any point on tangent or reverse crosslevel elevation on curves may not be more than .....	3	2	1¾	1¼	1
The difference in crosslevel between any two points less than 62 feet apart may not be more than <sup>*1, 2</sup> .....	3	2¼	2	1¾	1½
*Where determined by engineering decision prior to June 22, 1998, due to physical restrictions on spiral length and operating practices and experience, the variation in crosslevel on spirals per 31 feet may not be more than.....	2	1¾	1¼	1	¾

<sup>1</sup> Except as limited by § 213.57(a), where the elevation at any point in a curve equals or exceeds 6 inches, the difference in crosslevel within 62 feet between that point and a point with greater elevation may not be more than 1½ inches.

<sup>2</sup> However, to control harmonics on Class 2 through 5 jointed track with staggered joints, the crosslevel differences shall not exceed 1¼ inches in all of six consecutive pairs of joints, as created by seven low joints. Track with joints staggered less than 10 feet apart shall not be considered as having staggered joints. Joints within the seven low joints outside of the regular joint spacing shall not be considered as

*joints for purposes of this footnote.*

**Guidance:** Track surface is the evenness or uniformity of track in short distances measured along the tread of the rails. Under load, the track structure gradually deteriorates due to dynamic and mechanical wear effects of passing trains. Improper drainage, unstable roadbed, inadequate tamping, and deferred maintenance can create surface irregularities. Track surface irregularities can lead to serious consequences if ignored.

Allowable deviations in track surface include runoff at the end of a raise, deviation from uniform profile, deviation from zero crosslevel at any point on tangent or reverse crosslevel elevation on curves, and the difference in crosslevel between any two points less than 62 feet apart (referred as track warp), are specified in the track surface table. In addition, the table includes footnotes that address three special circumstances.

The first parameter in the table in this section refers to the runoff (ramp) in any 31-foot segment at the end of a raise where the track is elevated as a result of automatic or manual surfacing or bridge work. Conditions created by track degradation (e.g., settlement or frost heaves) are to be addressed using the uniform profile parameter, under this section. Trains encountering a ramp (up or down) will experience a vertical pitch or bounce if the change in elevation occurs in too short a distance. As in the more general profile parameter, damage to car components, undesirable brake applications or derailments may occur; especially when the vehicle experiences a lateral force such as a buff force. The following figure illustrates the measurement of the runoff of raised track.

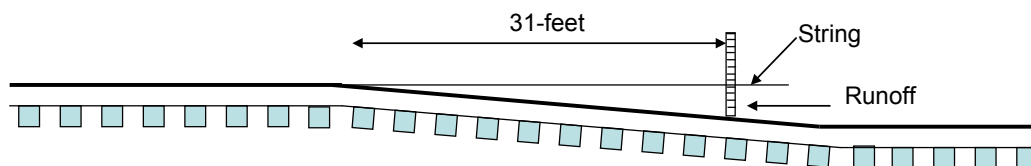

The second parameter, profile, relates to the elevation of either rail along the track. When trains encounter short dips or humps in the track it can result in vertical separation of couplers, broken springs, bolsters, and truck frames. Dips can result from mud spots, or develop at the ends of fixed structures (e.g., bridges, highway rail grade and track crossings). A profile is determined by placing the mid-point of a 62-foot chord at the point of maximum measurement, irrespective of vertical curves. A profile may also be a track “hump” caused by a frost heave or other occurrence. The following figure illustrates the measurement of profile conditions.

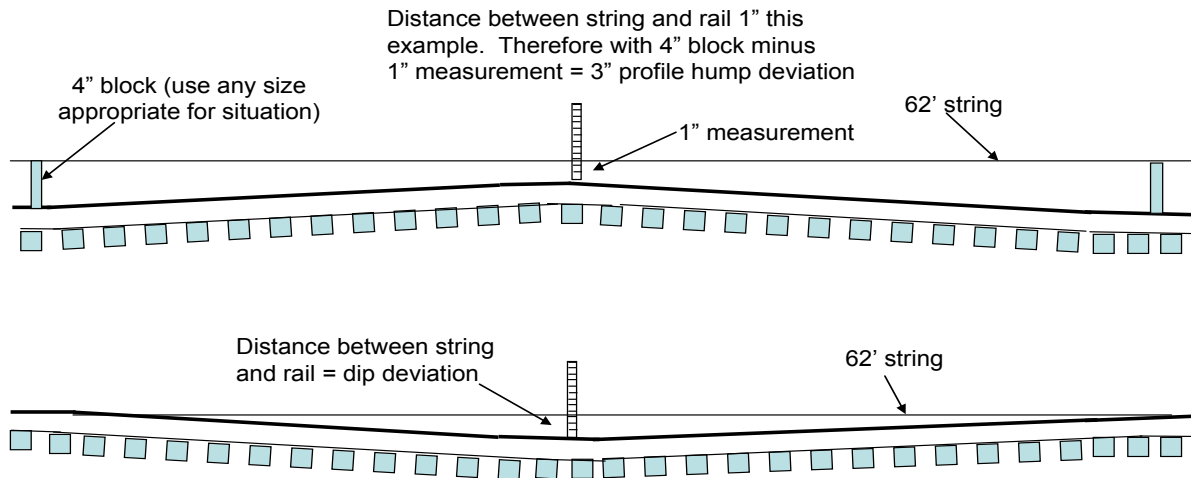

Remember to consider any combination of rail and tie plate or crosstie and ballast section voids to the mid-ordinate distance, according to § 213.13 (dynamic loading).

When encountering a hump (e.g., frost heaves over culverts), place two uniform (reference offset) blocks on top of the running rail. Stretch (taut) a 62-foot string over the blocks, with the observed highpoint at the midpoint of the string. Measure the distance from the string to the running surface of the rail. Subtract this distance from the height of the (offset) blocks to determine the mid-offset.

The third parameter in the table refers to the deviation from zero crosslevel at a point or reverse crosslevel in a curve. Crosslevel, utilizing a levelboard, is measured by subtracting the difference in height between the top surface (tread) of one rail to the tread of the opposite rail. On tangent track both rails by design should be the same height, a term known as zero crosslevel. On the spiral or body of a curve, the outer rail may not be lower than inner rail (reverse elevation) beyond the limits provided in the surface table. Also consider what implications, if any,  $V_{max}$  (§ 213.57) may impose at a curve body where reverse elevation is encountered.

The parameter for the difference in crosslevel between any two points less than 62 feet apart is commonly referred to as the “warp” parameter. This parameter provides maximum change in crosslevel between two points within specific distances along the track. The warp parameter is, perhaps, the most critical of the surface parameters. Excessive warp contributes to wheel climb derailments. The following illustrates warp measurements.



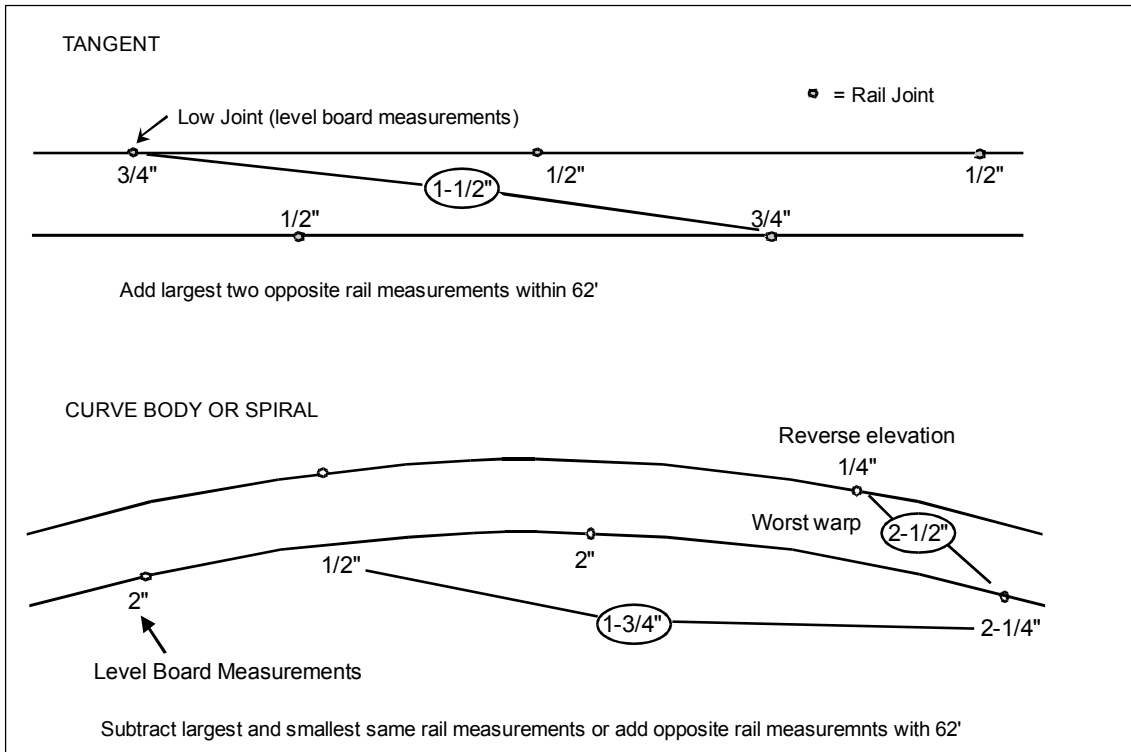

The threshold values for warp represent minimum safety standards and encompass the full range of rolling stock in present-day operating fleets. Inspectors should be aware that some rolling stock, because of certain design and/or demonstrated performance characteristics, may be subject to additional operating restrictions and/or more restrictive warp thresholds as determined by individual railroads. The limits for warp apply anywhere along the track, (curves, spirals, and tangent segments), except that the limits shown in footnote "\*" of the table apply in the special case in spirals where physical conditions prevent the more restrictive limits in the general warp parameter.

The footnote designated by a "\*" of table is an exception to the above warp requirement in spirals in those few situations where the railroad has made a prior engineering decision, due to physical restrictions, to design a shorter spiral that would be found in standard construction. When encountering a spiral that does not have a sufficient length to "runoff" elevation in accordance with the warp parameter, the inspector must determine if the "short spiral" is a result of a man made or other natural obstruction. In short spirals, the amount of warp is determined by measuring the "variation" in crosslevel between two points 31 feet apart.

Examples of "short spiral" situations include rock cuts, tunnels, station platforms, etc. The following figure illustrates the application of the "\*" footnote.

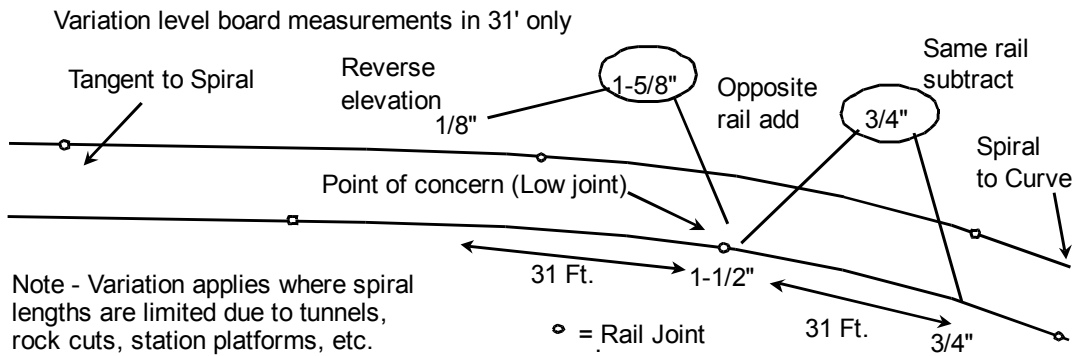

Railroads are expected to apply the variation parameter and thresholds only at locations where there is a clear history of restrictive physical characteristics.

When measuring track surface parameters remember the location of the transition points between tangent, spiral, and curve body are determined by actual physical layout and are not assumed to be synonymous with railroad markers, tags, curve charts, or similar information. Therefore, be governed accordingly when applying the "\*" footnote or any other track geometry parameter.

Under footnote 1 of the table, where the elevation at any point in a curve equals or exceeds 6 inches, the difference in crosslevel (warp) within 62 feet between that point and a point with greater elevation may not be more than 1½ inches regardless of track class. This footnote is included to address the condition where a vehicle is operating on a curve with a large amount of elevation and then encounters a warp condition. Since the vehicle is typically in an unbalanced condition, the warp may induce wheel climb. Slow speed curve negotiation is a particular concern since the wheels on the outside rail of the curve will tend to unload due to the overbalanced condition of the vehicle. Where this condition is found, the appropriate corrective action would be reduction to Class 1 speed under the provisions of § 213.9(b).

The following figure illustrates a warp exceeding 1½ inches at a curve with 6 inches of elevation.

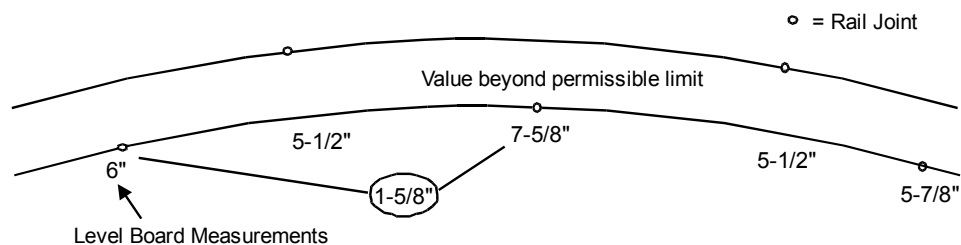

Footnote 2 of the table addresses the critical harmonic rock-off condition that may result in the vehicle rocking back and forth and derailling following wheel climb. It is considered rare that this condition could occur in CWR, but it may occur where "joint memory exists." In this case, while the condition is not a defect unless it exceeds the warp limits specified in the

table, the inspector should call the condition to the attention of the railroad. The crosslevel difference (warp) may not exceed 1¼ inches on all six consecutive pairs of joints, under the conventional joint spacing (33-, 36-, 39-foot long rails). Each one of the six pairs must exceed 1¼ inches for this condition to be a defect. Additional joints that have been introduced outside of the regular joint spacing, characteristically as a result of rail repair, are not considered harmonic “joints” for the purposes of this footnote. The following figure illustrates a harmonic rock-off condition.

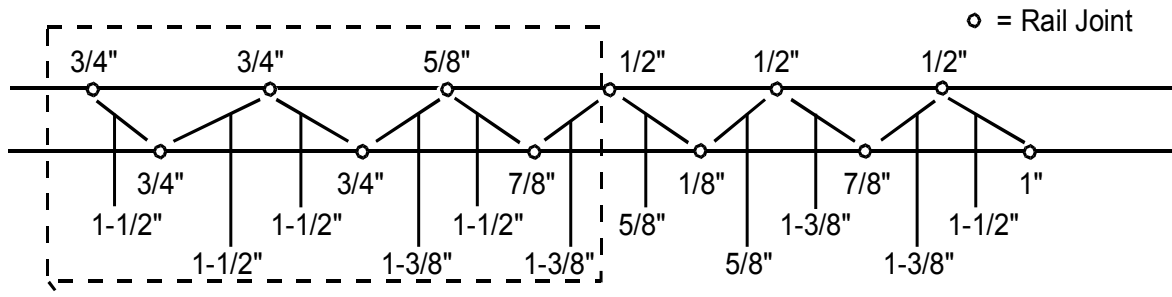

The worst single warp is 1-1/2" which is acceptable for Class 5 but six consecutive pair of joints have a difference that exceed 1-1/4" therefore the Class must be reduced to Class 1

A condition with consecutive low-bolted joints may be in noncompliance with either the warp limits specified in the table or the requirements of footnote 2 of the § 213.63 table. Inspectors shall consider any contiguous group of joints as one defect and note the number of joints. If the harmonic condition continues beyond the seven joints, the inspector is not required to record another defect, but must note the number of consecutive joints that make up the harmonic condition.

Jointed rail stagger that is not identical from stagger to stagger, such as in a curve or when a rail slightly longer than the original construction is installed, shall be considered in the harmonic calculation. Additional joints introduced by the installation of short rails are ignored in evaluating a harmonic condition.

Construction consisting of 79- or 80-foot rails does not result in harmonic rock-off conditions since they occur outside of vehicle truck spacing. For 79- or 80-foot rails and staggered spacing less than 10 feet, this footnote is not applicable and inspectors shall review the condition for compliance with other track surface parameters.

Inspectors shall carefully apply the provisions of footnote 2 of the § 213.63(a) table. An acceptable remedial action is to raise and tamp one or two joints in the middle of the consecutive low joints. This will break up the harmonics.

63(b) For operations at a qualified cant deficiency,  $E_u$ , of more than 5 inches, each track owner shall maintain the surface of the curve within the limits prescribed in the following table:

Track surface (inches)	Class of track				
	1	2	3	4	5
The deviation from uniform profile on either rail at the mid-ordinate of a 31-foot chord may not be more than .....	N/A <sup>1</sup>	N/A <sup>1</sup>	1	1	1

<i>The deviation from uniform profile on either rail at the mid-ordinate of a 62-foot chord may not be more than</i> .....	2¼	2¼	1¾	1¼	1
<i>The difference in crosslevel between any two points less than 10 feet apart (short warp) shall not be more than</i> .....	2	2	1¾	1¾	1½

<sup>1</sup>N/A—Not Applicable

**Guidance:** Paragraph 63(b) was introduced by the VTI final rule (78 FR 16101, Mar. 13, 2013). The paragraph contains tighter, single-deviation geometry limits for operations above 5 inches of cant deficiency on curves. These limits include tighter 62-foot mid-chord offset (MCO) track surface and 31-foot MCO limits for track surface and 10-foot warp - the difference in crosslevel between any two points less than 10 feet apart. The other limits in rows 1 and 3 to 5 in paragraph 63(a) are still applicable.

These limits provide an equivalent margin of safety for operations above 5 inches of cant deficiency. They are based on the results of simulation studies to determine the safe amplitudes of track geometry surface variations.

**§ 213.65 Combined track alignment and surface deviations.**

*On any curved track where operations are conducted at a qualified cant deficiency, E<sub>c</sub>, greater than 5 inches, the combination of alignment and surface deviations for the same chord length on the outside rail in the curve, as measured by a TGMS, shall comply with the following formula:*

$$\frac{3}{4} \times \left| \frac{A_m}{A_L} + \frac{S_m}{S_L} \right| \leq 1$$

Where—

*A<sub>m</sub>* = measured alignment deviation from uniformity (outward is positive, inward is negative).

*A<sub>L</sub>* = allowable alignment limit as per § 213.55(b) (always positive) for the class of track.

*S<sub>m</sub>* = measured profile deviation from uniformity (down is positive, up is negative).

*S<sub>L</sub>* = allowable profile limit as per § 213.63(b) (always positive) for the class of track.

$$\left| \frac{A_m}{A_L} + \frac{S_m}{S_L} \right| = \text{the absolute (positive) value of the result of } \frac{A_m}{A_L} + \frac{S_m}{S_L} .$$

**Guidance:** This section contains limits addressing combined track alignment and surface deviations for operations above 5 inches of cant deficiency on curves.

The equation is given for computing the combined track alignment and surface deviations within a single chord length. The limits are intended to be used only with a TGMS, and applied on the outside rail in curves.

The Track Safety Standards have traditionally prescribed limits on geometry variations existing in isolation. However, a combination of track alignment and surface variations may result in undesirable vehicle response, even though neither the alignment nor the surface variation individually amounts to a deviation from the requirements in this part.

Section § 213.333(a)(1) contains TGMS inspection requirements for operations with cant deficiencies greater than 5 inches over Class 1 through 5 track. These requirements apply as required by § 213.57(i). Trains operating at high cant deficiencies increase the lateral wheel force exerted on the outside rail during curving, and hence decrease the margin of safety associated with the VTI safety limits in § 213.333. To address these concerns, simulation studies were performed to determine the safe amplitudes of combined track geometry variations. Results of this research showed that the equation-based safety limits in this section can provide a margin of safety for vehicle operations at any speeds and higher than 5 inch cant deficiencies.

## Subpart D – Track Structure

### § 213.101 Scope

*This subpart prescribes minimum requirements for ballast, crossties, track assembly fittings, and the physical conditions of rails.*

### § 213.103 Ballast; general

*Unless it is otherwise structurally supported, all track shall be supported by material which will --*

*103(a) Transmit and distribute the load of the track and railroad rolling equipment to the subgrade;*

*103(b) Restrain the track laterally, longitudinally, and vertically under dynamic loads imposed by railroad rolling equipment and thermal stresses imposed by the rails;*

**Guidance:** Ballast may consist of crushed slag, crushed stone, screened gravel, pit-run gravel, chat, cinders, scoria, pumice, sand, mine waste, or other native material, and is an integral part of the track structure. Ballast, regardless of the material, must satisfy the requirements stated in the TSS.

*103(c) Provide adequate drainage for the track; and*

*103(d) Maintain proper track crosslevel, surface, and alinement.*

**Guidance:** Inspectors should consider the overall condition of a track when citing fouled ballast. Because ballast conditions can be subjective in nature, inspectors should also look to other indicators, such as a geometry condition. For example, a fouled ballast violation might be appropriate if the track has poor drainage and there is a geometry condition or a series of fouled ballast locations with geometry conditions. Repeated dynamic loading and unloading of rolling stock in these areas can cause wheel lift. Inspectors must take into account the amount that the geometry condition is beyond proper geometry when considering a fouled ballast defect. The appearance of mud in the track does not necessarily mean a fouled ballast defect should be written if the ballast section is properly transmitting the load, restraining the track, and providing proper geometry.

Inspectors are encouraged to exercise their technical knowledge and professional experience in citing fouled ballast. They should consider multiple factors, such as track class, adequacy of shoulder ballast, traffic density and wheel loads, and the potential that

the track deteriorates very rapidly following heavy rains during the wet season. In any case, if all track geometry parameters are well below the limits for the posted class, and there are no apparent signs that a defect will develop imminently, inspectors should not write a defect even if the ballast appears severely fouled.

The term “geometry condition” used here and elsewhere in this manual means a track surface, gage, or alignment irregularity that does not exceed the allowable threshold for the designated track class. It exists due to the reduced or non-existent capability of one or more track structural components to hold the track to its preferred geometric position.

### § 213.109 Crossties

109(a) *Crossties shall be made of a material to which rail can be securely fastened.*

109(b) *Each 39-foot segment of track shall have –*

- (1) *A sufficient number of crossties which in combination provide effective support that will -*
  - (i) *Hold gage within the limits prescribed in §213.53(b);*
  - (ii) *Maintain surface within the limits prescribed in §213.63; and*
  - (iii) *Maintain alignment within the limits prescribed in §213.55.*
- (2) *The minimum number and type of crossties specified in paragraphs (b)(4) of this section and described in paragraph (c) or (d), as applicable, of this section effectively distributed to support the entire segment; and*
- (3) *At least one non-defective crosstie of the type specified in paragraphs (c) and (d) of this section that is located at a joint location as specified in paragraph (e) of this section; and*
- (4) *The minimum number of crossties as indicated in the following table.*

<b><i>FRA Track Class</i></b>	<b><i>Tangent track and curves ≤ 2 degrees</i></b>	<b><i>Turnouts and curved track over 2 degrees</i></b>
<i>Class 1</i>	5	6
<i>Class 2</i>	8	9
<i>Class 3</i>	8	10
<i>Class 4 and 5</i>	12	14

**Guidance:** The TSS determines the adequacy of crosstie support by including its functional requirements to maintain track geometry within the limits specified in Subpart C. The failure of the crossties to meet any of the three above criteria constitutes a deviation from the TSS.

Effective distribution has not been defined, but must not be interpreted by the inspector as synonymous with equally spaced. The language is intended to address situations where all of the non-defective or defective ties exist in a group at a short area of the 39-foot segment of track in question. Evidence that crossties are not effectively distributed includes, primarily, indications of an actual deviation or a geometry condition.

No criterion exists for the maximum distance between non-defective ties, and this measurement should not be used to describe a tie defect. If such a description is appropriate, it should be in terms of the number of consecutive defective ties in a group.

When citing 213 defect code 0109B2 (Cross ties not effectively distributed to support a 39-foot segment of track), the inspector must show evidence of one or more of the geometry conditions cited in § 213.109(b)(1). Several factors may be documented if the defect is being cited. These factors include, but are not limited to:

- Geometry conditions.
- Class of track.
- Curvature.
- Traffic density (annual tonnage).
- Rail weight and condition.
- Condition of other components of the track.

When determining compliance with this section, the inspector must determine that cross ties meet the requirements of effectiveness as defined above and make geometry measurements to verify that each 39-foot segment of track has:

- A sufficient number of effective ties to maintain geometry.
- The required number of non-defective ties for the track class as described in paragraph (b)(4).
- The proper placement of nondefective ties as described in paragraph (b)(4) and positioned as required in paragraph (e) to support joints.

The majority of cross ties throughout the nation are made from wood. However, there are varieties of alternate designed cross ties made from materials such as composites, steel, and concrete. These types of cross ties are becoming more common throughout the industry. Because of the increased use of these alternate design cross ties and their associated resilient type rails fasteners, inspectors should more rigorously consider the rail/cross tie interface. Also, see § 213.127, Rail fastenings.

*109(c) Cross ties, other than concrete, counted to satisfy the requirements set forth in paragraph (b)(4) of this section shall not be—*

- (1) Broken through;*
- (2) Split or otherwise impaired to the extent the cross ties will allow the ballast to work through, or will not hold spikes or rail fasteners;*
- (3) So deteriorated that the tie plate or base of rail can move laterally more than ½ inch relative to the cross ties; or*
- (4) Cut by the tie plate through more than 40 percent of a ties' thickness.*

**Guidance:** Paragraph (c) mainly applies to wooden ties, although it does not explicitly exclude composite and steel ties.

When a cross tie exhibits any one or more of the conditions described in the four criteria for evaluation [§ 213.109(c)1–4] it may be considered non-effective itself, although that

determination may not always result in a defective condition that can be recorded under 213 Defect Codes 0109A, 0109B2, or 0109B3.

If track geometry measurements fail to meet the requirements of Subpart C, and there are an insufficient number of effective crossties, both geometry and crossties could be cited as defects. If geometry measurements exceed the allowable tolerance, but a determination cannot be made that crossties are the cause, it is appropriate to cite only the defective geometry.

FRA inspectors may use a PTLF described in § 213.110 for the purposes of measuring loaded gage to determine effective distribution of crossties. Refer to Appendix D–PTLF, instructions for non-GRMS territory under § 213.53.

109(d) *Concrete crossties counted to satisfy the requirements set forth in paragraph (b)(4) of this section shall not be--*

- (1) *Broken through or deteriorated to the extent that prestressing material is visible;*
- (2) *Deteriorated or broken off in the vicinity of the shoulder or insert so that the fastener assembly can either pull out or move laterally more than  $\frac{3}{8}$  inch relative to the crosstie;*
- (3) *Deteriorated such that the base of either rail can move laterally more than  $\frac{3}{8}$  inch relative to the crosstie on curves of 2 degrees or greater; or can move laterally more than  $\frac{1}{2}$  inch relative to the crosstie on tangent track or curves of less than 2 degrees;*
- (4) *Deteriorated or abraded at any point under the rail seat to a depth of  $\frac{1}{2}$  inch or more;*
- (5) *Deteriorated such that the crosstie's fastening or anchoring system, including rail anchors (see § 213.127(b)), is unable to maintain longitudinal rail restraint, or maintain rail hold down, or maintain gage due to insufficient fastener toeload; or*
- (6) *Configured with less than two fasteners on the same rail except as provided in § 213.127(c).*

**Guidance:** Crossties are evaluated individually by the definitional and functional criteria set forth in the regulations. Crosstie “effectiveness” is naturally subjective and requires good judgment in the application and interpretation of this standard. The soundness and durability of a crosstie is demonstrated when a 39-foot track segment maintains safe track geometry and structurally supports the imposed wheel loads with minimal deviation. Key to the track segment lateral, longitudinal, and vertical support is a strong track modulus, which is a measure of the vertical stiffness of the rail foundation. Continuous superior superstructure (including rails, crossties, fasteners, etc.) and high-quality ballast characteristics that transmit both dynamic and thermal loads to the subgrade are also important. Proper drainage that is free from the presence of excess moisture is an apparent and crucial factor in providing added structural support.

Section 213.109 contains specific performance requirements for FRA Classes 1 through 5 track that address the unique characteristics of fastener reliability, concrete crossties, and roadbed stability. Inspectors should be aware of the three modes of concrete crosstie failure: support, stability, and electrical isolation. The compressive strength of concrete and the amount of prestress in its section composition provide the strength and stiffness necessary to support expected wheel loads. There is a balance between excessive stiffness that can lead to higher stresses at the bottom of the crosstie and at the rail seat.



Conversely, a loss of stiffness, caused by ever increasing axle loading, can lead to excessive rail deflections and damage to the ballast and subgrade. Inspectors should be aware that failure modes are not isolated to crosstie defects. Combinations of compliant but irregular track and rail geometry, poor drainage, insufficient ballast depth and subgrade soil conditions may contribute to failure or root causal factors.

Paragraph (d) delineates the requirements related to concrete crossties. Modern concrete crossties are designed to accept the stresses imposed by irregular rail head geometry and loss, excessive wheel loading caused by wheel irregularities (out of round), excessive unbalance speed, and track geometry defects. Section 213.109 considers the worst combinations of conditions, which can cause excessive impact and eccentric loading stresses that would increase failure rates and other measures concerning loss of toeload, longitudinal and lateral restraint, in addition to improper rail cant.

Paragraph (d)(1) states that as with non-concrete crossties, concrete crossties counted to fulfill the requirements of paragraph (b)(4) must not be broken through or deteriorated to the extent that prestressing material is visible.

Crossties must not be so deteriorated that the prestressing material has visibly separated from, or visibly lost bond with, the concrete, resulting either in the crosstie's partial break-up, or in cracks that expose prestressing material due to spalls or chips, or in significant broken-out areas exposing prestressed material. Currently, metal reinforcing bars are used as the prestressing material in concrete crossties. FRA uses the term "prestressing material" in lieu of "metal reinforcing bars" to allow for future technological advances.

There is a distinction between the phrases "broken through" and "deteriorated to the extent that prestressing material is visible." Concrete crossties are manufactured in two basic designs: twin-block and mono-block. Twin-block crossties are designed with two sections of concrete connected by exposed metal rods. A mono-block crosstie is similar in dimension to a timber or wood crosstie and contains prestress metal strands embedded into the concrete. The prestressing material in the concrete is observed at the ends of the crosstie for proper tension position. Prestressed reinforced concrete crossties are made by stressing the reinforcing material in a mold, then pouring cement concrete over the reinforcing material in the mold. After the concrete cures, the tension on the reinforcing material is released, and the ends of the reinforcing material are trimmed, if appropriate for the use. The prestressing material remains in tension against the concrete, which is very strong in compression. This allows the prestressed concrete to withstand both compressive and tensile loads. If the concrete spalls, or if the prestressing material is otherwise allowed to come out of contact with the concrete, then the prestressing material is no longer in tension. A concrete crosstie's flexural strength and stiffness is lost when the prestress force is reduced through corrosion, concrete deterioration, or poor bond with the concrete due to improper manufacturing. The prestressing material may corrode if insufficient concrete cover or concrete cracking allows the intrusion of moisture and oxygen. When this happens, the once prestressed concrete crosstie can no longer withstand tensile loads, and it will fail very rapidly in service.

Prestressing material is often exposed in a concrete crosstie as a crack, but it can also be exposed on the side of the tie. When prestressing material becomes exposed on the side of a crosstie, the prestressing material is no longer in tension, the prestressed concrete can no longer withstand the tensile loads, and therefore a concrete crosstie can structurally fail. This does not apply to reinforcing material left visible at the end of the crosstie during the

manufacturing process.

The compressive strength of the concrete material and the amount of prestress applied in the manufacturing process provide the strength and stiffness necessary to adequately support and distribute wheel loads to the subgrade. The prestressing material encased in concrete hold the crosstie together and provides tensile strength. However, significant cracking or discernible deterioration exposure of the reinforcing strands to water and oxygen produces loss of the prestress force through corrosion, concrete deterioration, and poor bonding. Loss of the prestress force renders the crosstie susceptible to structural failure and as a consequence, stability failure relating to track geometry noncompliance.

Crossties transversely broken between the rail seats and showing signs of further deterioration (loss of tension in prestressing material—upper and lower levels of exposure to metal strands) constitute failure. This means that there cannot be a complete separation of the concrete material making up the crosstie. Crossties must not be so deteriorated that the prestressing material has visibly separated from, or visibly lost bond with, the concrete, resulting either in the crosstie's partial break-up, or in cracks that expose prestressing material due to spalls or chips, or in significant broken-out areas exposing prestressed material.

Crosstie failure is exhibited in three distinct ways: stress induced (breaks, cracks); mechanical (abrasion); or chemical decomposition. These conditions in small or large degrees compromise the crosstie's ability to maintain proper gage, alignment, and track surface. Walking inspections would demonstrate clearly visible spalls, chips, cracks, and similar breaks. However, the compression of prestressed concrete crossties may close cracks as they occur, making them difficult to observe. Even such closed cracks probably weaken the crossties.

Breaks or cracks are divided into three general conditions: longitudinal cracks, center cracks, and rail seat cracks. Longitudinal cracks are horizontal through the crosstie and extend parallel to its length. They are initiated by high impacts on one or both sides of the rail bearing inserts. Crosstie center cracks are vertical cracks extending transversely (across) the crosstie. These cracks are unusual and are the result of high negative bending movement (usually center bound), originating at the crosstie top and extend to the bottom. Generally, the condition is progressive, and adjacent crossties may be affected. Rail seat cracks are vertical cracks that are not easily visible. They usually extend from the bottom of the crosstie on one or both sides of the crosstie and are often hard to detect. It is possible for a crosstie to be broken through, but, due to the location of the break, the prestressing material may not be visible. Crosstie strength, generally, does not fail unless the crack extends through the top layer of the prestressing material. Once the crack extends beyond the top layer, there is usually a loss of prestressing material and concrete bond strength.

Paragraph (d)(2) makes clear that crossties counted to fulfill the requirements of paragraph (b)(4) of this section must not be deteriorated or broken off in the vicinity of the shoulder or insert so that the fastener assembly can either pull out or move laterally more than three-eighths inch relative to the crosstie, as these conditions weaken rail fastener integrity.

Paragraph (d)(3) provides that a crosstie counted to fulfill the requirements of (b)(4) must not be deteriorated such that the base of either rail can move laterally more than three-eighths inch relative to the crosstie on curves of 2 degrees or greater; or can move laterally more than one-half inch relative to the crosstie on tangent track or curves of less than 2

degrees. This section allows for a combination rail movement, inward and outward, up to the dimensions specified, but not separately for each rail. The rail and fastener assembly work as a system capable of providing electrical insulation, adequate resistance to lateral displacement, undesired gage widening, rail canting, rail rollover, and abrasive or excessive compressive stresses. In accordance with policy and procedures, inspectors are encouraged to use the assigned portable track loading fixture (PTLF) in assessing the amount of lateral rail movement, wherever applicable.

Paragraph (d)(4) requires that crossties counted to fulfill the requirements of paragraph (b)(4) of this section must not be deteriorated or abraded at any point under the rail seat to a depth of one-half inch or more. The measurement of one-half inch includes depth from the loss of rail pad material. The importance of having pad material in place with sufficient hysteresis (i.e., resilience (elasticity) to dampen high impact loading and recover) is paramount to control rail seat cracks caused by rail surface defects, wheel flats, or out of round wheels. Additionally, concrete crossties must be capable of providing adequate rail longitudinal restraint from excessive rail creepage or thermally induced forces or stress. “Rail creepage” is the tractive effort or pulling force exerted by a locomotive or car wheels, and “thermally induced forces or stress” is the longitudinal expansion and contraction of the rail, creating either compressive or tensile forces as the rail temperature increases or decreases, respectively. The loss of pad material causes a loss of toeload force, which may decrease longitudinal restraint. See the following figure. Note: inward or outward rail cant angle conventions are interchangeable among geometry measurement systems. FRA geometry cars record inward cant as positive, and outward cant as negative.

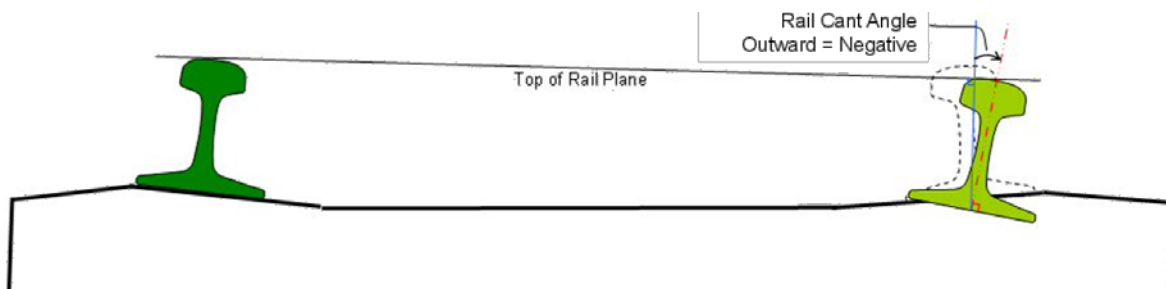

Paragraph (d)(5) requires that crossties counted to fulfill the requirements of paragraph (b)(4) of this section must not be deteriorated such that the crosstie’s fastening or anchoring system including rail anchors is unable to maintain longitudinal rail restraint, maintain rail hold down, or maintain gage, due to insufficient fastener toeload. Inspectors evaluate crossties individually by “definitional and functional” criteria. A compliant crosstie is demonstrated when a 39-foot track segment maintains safe track geometry and structurally supports the imposed wheel loads. In addition to ballast, anchors bear against the sides of crossties to control longitudinal rail movement, and certain types of fasteners also act to control rail movement by exerting a downward clamping force (toeload) on the upper rail base. Part of the complexity of crosstie assessment is the fastener component. Both crossties and fasteners act as a system to deliver the expected performance effect. A noncompliant crosstie and defective fastener assembly improperly maintains the rail position and support in the rail seat and contributes to excessive lateral gage widening (rail cant-rail rollover), and longitudinal rail movement because of loss of toeload.

Fastener assemblies or anchoring systems allow a certain amount of rail movement

through the crosstie to effectively relieve rail creepage (tractive and thermal force build-up). However, because of the unrestrained buildup caused by rail creep, the longitudinal expansion and contraction of the rail creates either compressive or tensile forces, respectively. When longitudinal rail movement is ‘uncontrolled,’ it may disturb the track structure, causing misalignment (compression) or pull-apart (tensile) conditions to catastrophic failure. Specific longitudinal performance metrics would be undesirable and restrict certain fastener assembly designs and capabilities to control longitudinal rail movement. Therefore, inspectors must use good judgment in determining fastener assembly and crosstie effectiveness.

Paragraph (d)(6) makes clear that crossties counted to fulfill the requirements of paragraph (b)(4) of this section must not be configured with less than two fasteners on the same rail, except as provided in amended § 213.127(c), which includes requirements specific to fasteners used in conjunction with concrete crossties. As with nonconcrete ties, one of the safety requirements of an effective concrete tie is its ability to hold fasteners.

109(e) Class 1 and 2 track shall have one crosstie whose centerline is within 24 inches of each rail joint (end) location. Class 3, 4, and 5 track shall have either one crosstie whose centerline is within 18 inches of each rail joint location or two crossties whose centerlines are within 24 inches either side of each rail joint location. The relative position of these crossties is described in the following three diagrams:

- (1) Each rail joint in Classes 1 and 2 track shall be supported by at least one crosstie specified in paragraph (c) and (d) of this section whose centerline is within 48 inches as shown in Figure 1.

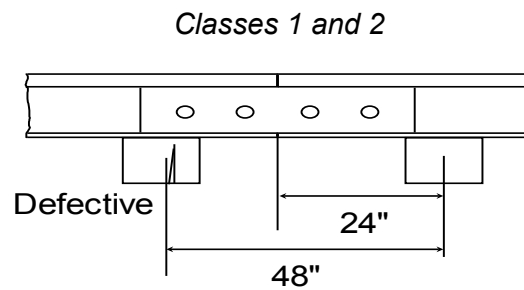

Figure 1

- (2) Each rail joint in Class 3, 4, and 5 track shall be supported by either at least one crosstie specified in paragraphs (c) and (d) of this section whose centerline is within 36 inches as shown in Figure 2, or:

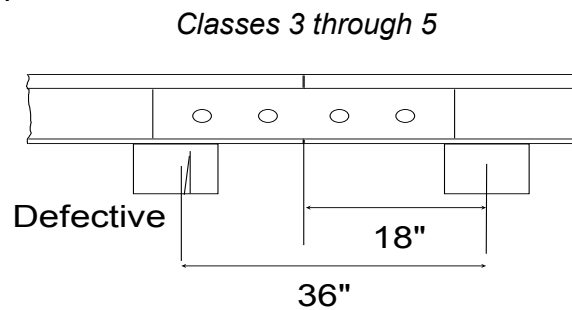
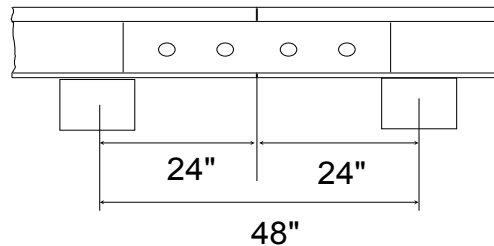

Figure 2

- (3) *Two crossties, one on each side of the rail joint, whose centerlines are within 24 inches of the rail joint location as shown in Figure 3.*

*Classes 3 through 5*



*Figure 3*

**Guidance:** A nondefective joint tie must be found within the prescribed distance of the centerline of the joint measured at the rail end. In Classes 3 through 5, joint tie placement can be satisfied by either a one tie configuration, or by a two-tie configuration.

For clarity of measurement and description:

1. Where a short piece of rail only inches in length is inserted between the rail ends and incorporated into the joint bar assembly, measure from the bar centerline. Also see § 213.121(d), Rail Joints.
2. Where nonsymmetrical bars exist, (e.g., five-hole heel block bars, five-hole compromise bars) measure from the design point where rail ends normally abut.

*109(f) For track constructed without crossties, such as slab track, track connected directly to bridge structural components, track over servicing pits, etc., the track structure shall meet the requirements of paragraph (b)(1) of this section.*

**Guidance:** This paragraph addresses track constructed without crossties or bridge timbers, such as concrete-slab track, in which running rails are secured through fixation to another structural member.

In general, discrepancies may arise in evaluation of crosstie conditions, if decisions are based only on an inspector's maintenance experience, which varies widely among the inspectors. Inspectors should evaluate tie condition solely on the basis of the definitions provided in this section. Each crosstie must be evaluated individually by these criteria. As with all provisions of the TSS, the inspector must use judgment and discretion in the application of the crosstie standards. They should be used to describe conditions that constitute a risk to the safe operation of trains, and should not be applied in doubtful cases.

Gage rods are not an effective substitute for a proper crosstie and rail-fastening system. Gage rods can be subject to sudden failure, they provide no vertical rail support, and they provide no resistance to rail roll-over forces. However, gage rods may be installed when they are used as a secondary means of support for maintaining gage. Where gage rods are used and it is obvious that the condition of the crosstie and fastening system in the immediate vicinity is incapable of maintaining adequate gage, then the inspector should consider citing a crosstie or fastener defect.

Certain crossties may not be able to hold spikes or rail fasteners in their present condition. In these cases, it may be possible to bring the crossties into compliance by either plugging and re-spiking, or adding additional rail-holding or plate-holding spikes, or both.

Where conditions are closer to a rail-fastener issue (e.g., sound ties in track are not fastened to the rail), inspectors should refer to the guidance under § 213.127.

### **§ 213.110 Gage Restraint Measurement Systems**

*110(a) A track owner may elect to implement a Gage Restraint Measurement System (GRMS), supplemented by the use of a Portable Track Loading Fixture (PTLF), to determine compliance with the crosstie and fastener requirements specified in §§213.109 and 213.127 provided that--*

- (1) The track owner notifies the appropriate FRA Regional office at least 30 days prior to the designation of any line segment on which GRMS technology will be implemented; and*
- (2) The track owner notifies the appropriate FRA Regional office at least 10 days prior to the removal of any line segment from GRMS designation.*

**Guidance:** This paragraph provides for the implementation of a GRMS, supplemented by the use of a PTLF, to determine compliance with the crosstie and rail fastener requirements specified in §§ 213.109 and 213.127. Track owners electing to implement this technology must provide the appropriate FRA regional office with notification that specifically identifies the line segments where GRMS will be used. The appropriate FRA office is the headquarters location for the FRA region in which the GRMS designated line segment is located.

The notification must be provided to FRA at least 30 days prior to the designation of any line segment which will be subject to the requirements of this section. Even though the notification requirement is satisfied, and the GRMS vehicle is determined to meet the minimum design requirements, the actual “triggering event,” which places the line segment under the GRMS requirements, is the initial track survey with the GRMS vehicle.

Track owners must also provide FRA with at least 10 days’ notice prior to the removal of a line segment from GRMS designation. This requirement provides FRA with advance notice of the criteria change for the inspection of crossties and fasteners, and places some control over the random removal of line segments from GRMS designation.

*110(b) Initial notification under paragraph (a)(1) of this section shall include--*

- (1) Identification of the line segment(s) by timetable designation, milepost limits, class of track, or other identifying criteria; and*
- (2) The most recent record of million gross tons of traffic per year over the identified segment(s).*

**Guidance:** This paragraph specifies what information track owners should include in their notifications to FRA about line segments designated for GRMS inspection. The information must include, at a minimum, the segment's timetable designation, milepost limits, track class, million gross tons of traffic per year, and any other identifying characteristics of the segment.

For reasons of safety, GRMS vehicles have their split-axle in the retracted position when testing through special trackwork such as turnouts at grade rail-to-rail crossings (diamond), expansion joints, lift rail assemblies, etc. Where certain trackage within is not part of the

designation, notifications should identify what and where these locations are and what distance approaching and leaving these locations are also excluded from GRMS designation. Locations excluded from GRMS designation will be subject to the requirements of §§ 213.109 and 213.127.

*110(c)(1) The track owner shall also provide to FRA sufficient technical data to establish compliance with the following minimum design requirements of a GRMS vehicle:*

*(2) Gage restraint shall be measured -between the heads of rail—*

- (i) At an interval not exceeding 16 inches;*
- (ii) Under an applied vertical load of no less than 10 kips per rail; and*
- (iii) Under an applied lateral load that provides for a lateral/vertical load ratio of between 0.5 and 1.2<sup>5</sup>, and a load severity greater than 3 kips but less than 8 kips per rail.*

**Guidance:** This paragraph describes minimum design requirements for GRMS vehicles. Track owners must submit to FRA sufficient technical data so that the agency can establish whether the track owner is in compliance with these design requirements. This paragraph requires that gage must be measured between the heads of the rail at an interval not exceeding 16 inches. The paragraph provides for design flexibility by establishing acceptable ranges for the lateral/vertical load ratio and the resulting lateral load severity, both of which can be satisfied by various load configurations, provided that the applied vertical load is not less than 10 kips per rail.

The rule provides for design flexibility by establishing acceptable ranges for various loading requirements. These ranges are considered absolute, and loading configurations that fall outside of the prescribed ranges will not be considered acceptable. Some loading configurations may develop high lateral/vertical load ratios and therefore lubrication of the gage face of the rail ahead of the split axle may be required to reduce the coefficient of friction to prevent wheel climb. Footnote 5 to this section cautions operations at L/V ratios exceeding 0.8 to protect against the risk of wheel climb by the test wheelset. This footnote is identical to footnote 5, which applies to § 213.333, Automated vehicle-based inspection systems, to ensure conformity between this section and its subpart G counterpart.

*110(d) Load severity is defined by the formula:*

$$S = L - cV$$

*Where-*

*S = Load severity, defined as the lateral load applied to the fastener system (kips).*

*L = Actual lateral load applied (kips).*

*c = Coefficient of friction between the rail/tie, which is assigned a nominal value of 0.4.*

*V = Actual vertical load applied (pounds), or static vertical wheel load if vertical load is not measured.*

**Guidance:** This paragraph prescribes a formula for the calculation of “load severity” required by 110(c)(2) iii. The coefficient of friction at rail/tie interface can change the load severity level when the applied actual lateral and vertical loads are given. However, it is impractical to determine the actual coefficients of friction, which vary from place to place in the GRMS territory. A nominal value of 0.4 can always be used.

---

<sup>5</sup> *GRMS equipment using load combinations developing L/V ratios that exceed 0.8 shall be operated with caution to protect against the risk of wheel climb by the test wheelset.*

110(e) *The measured gage values shall be converted to a Projected Loaded Gage 24 (PLG 24) as follows–*

$$PLG\ 24 = UTG + A \times (LTG - UTG)$$

Where –

*UTG = Unloaded track gage measured by the GRMS vehicle at a point no less than 10-feet from any lateral or vertical load application.*

*LTG = Loaded track gage measured by the GRMS vehicle at a point no more than 12 inches from the lateral load application point.*

*A = The extrapolation factor used to convert the measured loaded gage to expected loaded gage under a 24-kip lateral load and a 33-kip vertical load.*

*For all track –*

$$A = \frac{13.513}{(L - 0.258 \times V) - .009 \times (L - 0.258 \times V)^2}$$

*Note: The A factor shall not exceed a value of 3.184 under any valid loading configuration.*

*Where*

*L = Actual lateral load applied (kips).*

*V = Actual vertical load applied (kips), or static vertical wheel load if vertical load is not measured.*

**Guidance:** This paragraph prescribes the formula for the calculation of the projected loaded gage 24 (PLG 24). The formula provides a method to normalize the PLG regardless actual lateral load loads applied by different GRMS systems. Accurate measurements of unloaded gage, GRMS loaded gage, and the lateral load applied are of critical importance because these measurements are used in the calculation of PLG 24 values which constitute a direct measure of track strength.

To minimize the influence from adjacent loads, the unloaded track gage (UTG) must be measured by the GRMS vehicle at a point no less than 10 feet from any lateral or vertical load application and the loaded track gage (LPG) at a point no more than 12 inches from the lateral load application point.

110(f) *The measured gage and load values shall be converted to a Gage Widening Projection (GWP) as follows:*

$$GWP = (LTG - UTG) \times \frac{8.26}{L - 0.258 \times V}$$

**Guidance:** This paragraph prescribes the formula for the calculation of the gage widening projection (GWP). The GWP is intended to compensate for the weight of the testing vehicle. Use of the GWP is supported by research results documented in the report titled “Development of Gage Widening Projection Parameter for the Deployable Gage Restraint Measurement System” (DOT/FRA/ORD-06/13, October 2006), which is available on FRA’s Web site.



By making the criteria in this section consistent with those in § 213.333 in subpart G, the rule makes it easier for a track owner or railroad to comply with GRMS requirements regardless of the class of track.

*110(g) The GRMS vehicle shall be capable of producing output reports that provide a trace, on a constant-distance scale, of all parameters specified in paragraph (l) of this section.*

*110(h) The GRMS vehicle shall be capable of providing an exception report containing a systematic listing of all exceptions, by magnitude and location, to all the parameters specified in paragraph (l) of this section.*

*110(i) The exception reports required by this section shall be provided to the appropriate person designated as fully qualified under §213.7 prior to the next inspection required under §213.233.*

**Guidance:** Paragraphs (g), (h), and (i) require that GRMS vehicles be capable of producing a stripchart of all the parameters specified in paragraph (l) of this section, as well as a printed exception report listing, by magnitude and location, all exceptions from these parameters. The exception report listing must be provided to the appropriate persons designated as fully qualified under § 213.7 prior to the next inspection required under § 213.233 of the TSS.

Since the premise behind GRMS technology is to identify areas of weak gage restraint that either need immediate attention or must be continually monitored until the next GRMS inspection, the exception report listing must be retained and be available for review by the § 213.7 inspection personnel. FRA inspectors will obtain, or have access to, this exception report when conducting regular compliance inspections over GRMS designated line segments.

*110(j) The track owner shall institute the necessary procedures for maintaining the integrity of the data collected by the GRMS and PTLF systems. At a minimum, the track owner shall—*

- (1) Maintain and make available to the Federal Railroad Administration documented calibration procedures on each GRMS vehicle which, at a minimum, shall specify a daily instrument verification procedure that will ensure correlation between measurements made on the ground and those recorded by the instrumentation with respect to loaded and unloaded gage parameters; and*
- (2) Maintain each PTLF used for determining compliance with the requirements of this section such that the 4,000-pound reading is accurate to within five percent of that reading.*

**Guidance:** This paragraph requires the track owner to institute procedures that will ensure the integrity of data collected by the GRMS and PTLF systems. Track owners must maintain documented calibration procedures on each GRMS vehicle and make them available upon request from an FRA representative. A daily instrument verification procedure is required to ensure that measurements of loaded and unloaded gage recorded by the instrumentation correlate to actual field measurements. Track owners must also develop and implement the necessary PTLF inspection and maintenance procedures so that the 4,000-pound reading is accurate within plus or minus 5 percent.

*110(k) The track owner shall provide training in GRMS technology to all persons designated as fully qualified under §213.7 and whose territories are subject to the requirements of this section.*

*The training program shall be made available to the Federal Railroad Administration upon request. At a minimum, the training program shall address--*

- (1) Basic GRMS procedures;*
- (2) Interpretation and handling of exception reports generated by the GRMS vehicle;*
- (3) Locating and verifying defects in the field;*
- (4) Remedial action requirements;*
- (5) Use and calibration of the PTLF; and*
- (6) Recordkeeping requirements.*

**Guidance:** This paragraph recognizes the need for persons designated as fully qualified under § 213.7, and whose territories are subject to the requirements of this section, to receive training on the implementation of GRMS technology. The track owner therefore is required to develop a formal GRMS training program that must be made available to FRA upon request. The training of affected employees is another “triggering event” that must be satisfied prior to a line segment being designated as GRMS territory under this section.

The training program must provide detailed instruction on the specific areas identified in this paragraph. In particular, the training must address basic GRMS operational procedures, interpretation and handling of exception reports, how to locate and verify GRMS defects in the field, remedial action requirements to be initiated when defects are verified, how to use and calibrate the PTLF, and the recordkeeping requirements associated with the implementation of GRMS technology.

The requirement for GRMS training applies to fully qualified § 213.7 personnel under paragraphs (a) and (b) who are going to be subject to the requirements of this section. This is not to say that all fully qualified § 213.7 personnel need this training (e.g., welder foreman, production gang foreman, etc.). It is also not necessary for all fully qualified § 213.7 personnel who receive the GRMS training to be issued PTLFs. However, if circumstances arise where they need a PTLF, they should have access to one and be trained in how to use it and interpret the results.

The track owner must also take into consideration any relief personnel, newly qualified personnel, or personnel transferred from non-GRMS territory into a GRMS territory, which will be subject to the GRMS requirements. These personnel must be provided with sufficient instructions and training that enable them to demonstrate to the track owner that they know and understand the requirements of this section.

*110(l) The GRMS record of lateral restraint shall identify two exception levels. At a minimum, the track owner shall initiate the required remedial action at each exception level as defined in the following table--*

<i>GRMS parameters<sup>1</sup></i>	<i>If measurement value exceeds</i>	<i>Remedial action required</i>
<b><i>First Level Exception</i></b>		
<i>UTG.....</i>	<i>58 inches.....</i>	<i>(1) Immediately protect the exception location with a 10 m.p.h. speed restriction, then verify location; (2) Restore lateral restraint and maintain in compliance with PTLF criteria as described in paragraph (m) of this section; and (3) Maintain compliance with § 213.53(b) as</i>
<i>LTG.....</i>	<i>58 inches.....</i>	
<i>PLG24....</i>	<i>59 inches.....</i>	
<i>GWP.....</i>	<i>1 inch.....</i>	

		<i>measured with the PTLF.</i>
<b>Second Level Exception</b>		
LTG.....	57 ¾ inches on Class 4 and 5 track <sup>2</sup> .....	(1) Limit operating speed to no more than the maximum allowable under § 213.9 for Class 3 track, then verify location;
PLG24.....	58 inches.....	(2) Maintain in compliance with PTLF criteria as described in paragraph (m) of this section; and
GWP.....	0.75 inch.....	(3) Maintain compliance with §213.53(b) as measured with the PTLF.

<sup>1</sup> Definitions for the GRMS parameters referenced in this table are found in paragraph (p) of this section.

<sup>2</sup> This note recognizes that good track will typically increase in total gage by as much as one-quarter of an inch due to outward rail rotation under GRMS loading conditions. For Class 2 and 3 track, the GRMS LTG values are also increased by one-quarter of inch to a maximum of 58 inches. However, for any class of track, GRMS LTG values in excess of 58 inches are considered First Level exceptions and the appropriate remedial action(s) must be taken by the track owner. This 1/4-inch increase in allowable gage applies only to GRMS LTG. For gage measured by traditional methods, or with the use of the PTLF, the table in §213.53(b) applies.

**Guidance:** The VTI final rule has corrected the table to renumber the remedial action specified for a second level exception. The remedial action has been designated as (1), (2), and (3) in the “Remedial action required” column, to be consistent with the remedial action specified for a first level exception. This paragraph specifies the parameters and threshold levels required to be reported as a record of lateral restraint following an inspection by a GRMS vehicle. The regulation requires that two levels of exceptions be reported during the GRMS inspection. Specific remedial actions are required for each level, as identified in the “Remedial action required” column. First level exceptions are required to be immediately protected by a 10 mph speed restriction until verification and corrective action can be instituted. Second level exceptions are to be monitored and maintained within the PTLF criteria outlined in paragraph (m) of this section.

The prior knowledge criteria is satisfied for those locations that are identified as first or second level exceptions on the record of lateral restraint which is generated following each GRMS inspection. Where field inspections conducted between GRMS inspections reveal an exception location that does not comply with either the track strength requirement or the gage requirement that are identified in paragraph (m) of this section, the inspector should consider recommending civil penalties. For locations that do not comply with the requirements of paragraph (m), and have not been identified on the record of lateral restraint as either a first or second level exception, the inspector shall exercise discretion to determine whether or not civil penalties should be recommended.

Footnote 2 in the table recognizes that typical good track will increase in total gage by as much as one-quarter inch due to outward rail rotation under GRMS loading conditions. Accordingly, for Class 2 and Class 3 track, the GRMS loaded track gage values are also increased by one-quarter inch to a maximum of 58 inches. GRMS loaded track gage values in excess of 58 inches must always be considered first level exceptions. This ¼-inch increase in gage applies only to GRMS loaded gage, and does not apply to PTLF gage measurements or to measurements made by more traditional methods.

*110(m) Between GRMS inspections, the PTLF may be used as an additional analytical tool to assist fully qualified §213.7 individuals in determining compliance with the crosstie and fastener requirements of §§213.109 and 213.127. When the PTLF is used, whether as an additional analytical tool or to fulfill the requirements of paragraph (l), it shall be used subject to the following criteria–*

- (1) At any location along the track that the PTLF is applied, that location will be deemed in compliance with the crosstie and fastener requirements specified in §§213.109 and 213.127 provided that–*
  - (i) The total gage widening at that location does not exceed  $\frac{5}{8}$  inch when increasing the applied force from 0 to 4,000 pounds; and*
  - (ii) The gage of the track under 4,000 pounds of applied force does not exceed the allowable gage prescribed in §213.53(b) for the class of track.*
- (2) Gage widening in excess of  $\frac{5}{8}$  inch shall constitute a deviation from Class 1 standards.*
- (3) A person designated as fully qualified under §213.7 retains the discretionary authority to prescribe additional remedial actions for those locations, which comply with the requirements of paragraph (m)(1)(i) and (ii) of this section.*
- (4) When a functional PTLF is not available to a fully qualified person designated under §213.7, the criteria for determining crosstie and fastener compliance shall be based solely on the requirements specified in §§213.109 and 213.127.*
- (5) If the PTLF becomes non-functional or is missing, the track owner will replace or repair it before the next inspection required under §213.233.*
- (6) Where vertical loading of the track is necessary for contact with the lateral rail restraint components, a PTLF test will not be considered valid until contact with these components is restored under static loading conditions.*

**Guidance:** While the remedial action table in paragraph (l) requires the use of the PTLF to measure compliance with the lateral restraint and gage requirements at identified exception locations in GRMS territory, paragraph (m) also provides for the use of a PTLF as an additional analytical tool by fully qualified § 213.7 individuals at other locations in GRMS territory. Paragraph (m) also describes the manner in which a PTLF must be used in GRMS territory, whether it is being used as an additional analytical tool or being used to meet the remedial action requirements set forth in paragraph (l). Compliance with §§ 213.109 and 213.127 will be demonstrated when a PTLF is applied and (1) the total gage widening at that location does not exceed five-eighths inch when increasing the applied force from 0 to 4,000 pounds; and (2) the gage of the track measured under 4,000 pounds of applied force does not exceed the allowable gage prescribed in § 213.53(b) of this section for the class of track involved. Gage widening in excess of five-eighths inch shall constitute a deviation from Class 1 standards.

At locations where compliance with the crosstie and rail fastener requirements have been demonstrated through the use of a PTLF, a fully qualified § 213.7 individual retains the discretionary authority to prescribe additional remedial actions, such as the placement of speed restrictions, if the individual deems it necessary. FRA inspectors will determine compliance with the crosstie and fastener requirements for gage restraint solely on the basis of the PTLF measurements.

Where crossties are found to be so severely split or plate-cut to the extent that they are incapable of providing adequate vertical support, and conditions have degraded to the point where track surface conditions are approaching the allowable limit for the class of track, inspectors shall continue to consider writing a defect. In such a case use 213 defect code 0109B2, “crossties not effectively distributed to support a 39-foot segment of track.” Inspectors should record the track surface geometry condition as well as the contributing condition of the crossties in the description column.

When a functional PTLF is not available to a fully qualified § 213.7 individual during a scheduled inspection under § 213.233 of this part, the track owner must repair or replace the PTLF prior to the next inspection required under § 213.233, or crosstie and rail fastener compliance will be based solely on the requirements specified in §§ 213.109 and 213.127.

At locations where crosstie or rail fastening compliance is questioned and vertical loading of the track structure is necessary to restore contact with the lateral rail restraint components, the crossties must be raised until lateral restraint contact is restored and a PTLF measurement must then be made.

If the track owner fails to immediately restore contact between the rail and the fastening system so that a valid PTLF test can be performed, this non-action will in effect remove this location from the GRMS standard and the inspector will determine compliance based on §§ 213.109 and 213.127.

Likewise, where gage rods have been installed which preclude a valid PTLF test to determine gage restraint of crossties and fasteners, this action will in effect remove the location from the GRMS standard and the inspector will determine compliance based on §§ 213.109 and 213.127.

*110(n) The track owner shall maintain a record of the two most recent GRMS inspections at locations which meet the requirements specified in §213.241(b). At a minimum, records shall indicate the following--*

- (1) Location and nature of each First Level exception; and*
- (2) Nature and date of remedial action, if any, for each exception identified in paragraph (n)(1) of this section.*

**Guidance:** This paragraph requires the track owner to maintain a record of the two most recent GRMS inspections at locations meeting the requirements specified in § 213.241(b). The records must indicate the location and nature of each First Level exception, and the nature and date of initiated remedial action, if any, for each First Level exception. First Level exceptions are described in the Remedial Action Table in paragraph (l).

The record required under paragraph (n) is also the official record of lateral restraint and needs to identify both exception levels; however, the remedial action taken is required to be shown only for First Level exceptions. Records will be maintained at locations that meet the requirements specified in § 213.241(b).

*110(o) The inspection interval for designated GRMS line segments shall be such that--*

- (1) *On line segments where the annual tonnage exceeds two million gross tons, or where the maximum operating speeds for passenger trains exceeds 30 m.p.h., GRMS inspections must be performed annually at an interval not to exceed 14 months; or*
- (2) *On line segments where the annual tonnage is two million gross tons or less and the maximum operating speed for passenger trains does not exceed 30 m.p.h., the interval between GRMS inspections must not exceed 24 months.*

**Guidance:** Paragraph (o) details the GRMS inspection requirements illustrated in the following table:

<b>TRAFFIC</b>	<b>GRMS INSPECTION INTERVAL</b>
If annual tonnage exceeds 2MGT, or passenger train speeds (if applicable) exceed 30 mph, <u>then</u>	GRMS inspections must be performed annually at an interval not to exceed 14 months [1]
If annual tonnage is 2MGT or less, and where passenger train speeds (if operated) do not exceed 30 mph, <u>then</u>	The interval between GRMS inspections must not exceed 24 months [2]

[1] The maximum interval of 14 months is intended to provide some flexibility for scheduling when it may not be possible to schedule annual inspections within the same calendar month each year.

[2] This extended frequency is an attempt to make the technology more accessible to short line operators who may not have the financial or equipment resources available to larger railroads. For example, a GRMS inspection may be scheduled at up to 24-month intervals if the railroad had 2 million annual tons or less and passenger trains were not authorized to operate at more than 30 mph.

**110(p) As used in this section--**

- (1) *Gage Restraint Measurement System (GRMS) means a track loading vehicle meeting the minimum design requirements specified in this section.*
- (2) *Gage Widening Projection (GWP) means the measured gage widening, which is the difference between loaded and unloaded gage, at the applied loads, projected to reference loads of 16 kips of lateral force and 33 kips of vertical force.*
- (3) *L/V ratio means the numerical ratio of lateral load applied at a point on the rail to the vertical load applied at that same point. GRMS design requirements specify an L/V ratio of between 0.5 and 1.25.*
- (4) *Load severity means the amount of lateral load applied to the fastener system after friction between rail and tie is overcome by any applied gage-widening lateral load.*
- (5) *Loaded Track Gage (LTG) means the gage measured by the GRMS vehicle at a point no more than 12 inches from the lateral load application point.*
- (6) *Portable Track Loading Fixture (PTLF) means a portable track loading device capable of applying an increasing lateral force from 0 to 4,000 pounds on the web/base fillet of each rail simultaneously.*
- (7) *Projected Loaded Gage (PLG) means an extrapolated value for loaded gage calculated from actual measured loads and deflections. PLG 24 means the extrapolated value for loaded gage under a 24,000 pound lateral load and a 33,000 pound vertical load.*
- (8) *Unloaded Track Gage (UTG) means the gage measured by the GRMS vehicle at a point no less than 10-feet from any lateral or vertical load.*

**Guidance:** This paragraph prescribes a list of definitions of terms essential to the implementation of GRMS technology.

A well-documented pattern of repeated or widespread deviations from the requirements of this section by the track owner will effectively terminate the options afforded by this section. The affected track would then become subject to the requirements of §§ 213.109 and 213.127.

### **§ 213.113 Defective rails**

*113(a) When an owner of track learns that a rail in the track contains any of the defects listed in the table contained in paragraph (c) of this section, a person designated under § 213.7 shall determine whether the track may continue in use. If the designated person determines that the track may continue in use, operation over the defective rail is not permitted until –*

- (1) The rail is replaced or repaired; or*
- (2) The remedial action prescribed in the table contained in paragraph (c) of this section is initiated.*

*113(b) When an owner of track learns that a rail in the track contains an indication of any of the defects listed in the table contained in paragraph (c) of this section, the track owner shall verify the indication. The track owner must verify the indication within four hours, unless the track owner has an indication of the existence of a defect that requires remedial action A, A2, or B identified in the table contained in paragraph (c) of this section, in which case the track owner must immediately verify the indication. If the indication is verified, the track owner must--*

- (1) Replace or repair the rail; or*
  - (2) Initiate the remedial action prescribed in the table contained in paragraph (c) of this section.*
- (c) A track owner who learns that a rail contains one of the following defects shall prescribe the remedial action specified if the rail is not replaced or repaired, in accordance with this paragraph's table:*

**REMEDIAL ACTION TABLE**

Defect	Length of defect (inches)		Percentage of existing rail head cross-sectional area weakened by defect		If the defective rail is not replaced or repaired, take the remedial action prescribed in note
	More than	But not more than	Less than	But not less than	
<b>Compound Fissure</b>	..... ..... .....	..... ..... .....	70..... 100..... .....	5..... 70..... 100.....	B. A2. A.
<b>Transverse Fissure</b> <b>Detail Fracture</b> <b>Engine Burn Fracture</b> <b>Defective Weld</b>	..... ..... ..... .....	..... ..... ..... .....	25..... 60..... 100..... .....	5..... 25..... 60..... 100.....	C. D. A2, or [E and H]. A, or [E and H].
<b>Horizontal Split Head</b> <b>Vertical Split Head</b> <b>Split Web</b> <b>Piped Rail</b> <b>Head Web Separation</b> <b>Defective Weld (Longitudinal)</b>	1..... 2..... 4..... ( <sup>1</sup> ).....	2..... 4..... ..... ( <sup>1</sup> ).....	..... ..... ..... .....	..... ..... ..... .....	H and F. I and G. B. A.
<b>Bolt Hole Crack</b>	½..... 1..... 1½..... ( <sup>1</sup> ).....	1..... 1½..... ..... ( <sup>1</sup> ).....	..... ..... ..... .....	..... ..... ..... .....	H and F. H and G. B. A.
<b>Broken Base</b>	1..... 6 ( <sup>2</sup> ).....	6..... .....	..... .....	..... .....	D. A, or [E and I].
<b>Ordinary Break</b>	.....	.....	.....	.....	A or E.
<b>Damaged Rail</b>	.....	.....	.....	.....	C.
<b>Flattened Rail</b> <b>Crushed Head</b>	Depth ≥ 3/8 and Length ≥ 8.....	.....	.....	.....	H.

(1) Break out in rail head.

(2) Remedial action D applies to a moon-shaped breakout, resulting from a derailment, with length greater than 6 inches but not exceeding 12 inches and width not exceeding one-third of the rail base width.



**Notes:**

*A. Assign a person designated under § 213.7 to visually supervise each operation over the defective rail.*

*A2. Assign a person designated under § 213.7 to make a visual inspection. After a visual inspection, that person may authorize operation to continue without continuous visual supervision at a maximum of 10 m.p.h. for up to 24 hours prior to another such visual inspection or replacement or repair of the rail.*

*B. Limit operating speed over the defective rail to that as authorized by a person designated under § 213.7(a), who has at least one year of supervisory experience in railroad track maintenance. The operating speed cannot be over 30 m.p.h. or the maximum allowable speed under § 213.9 for the class of track concerned, whichever is lower.*

*C. Apply joint bars bolted only through the outermost holes to the defect within 10 days after it is determined to continue the track in use. In the case of Class 3 through 5 track, limit the operating speed over the defective rail to 30 m.p.h. until joint bars are applied; thereafter, limit the speed to 50 m.p.h. or the maximum allowable speed under § 213.9 for the class of track concerned, whichever is lower. When a search for internal rail defects is conducted under § 213.237, and defects are discovered in Class 3 through 5 track that require remedial action C, the operating speed shall be limited to 50 m.p.h. or the maximum allowable speed under § 213.9 for the class of track concerned, whichever is lower, for a period not to exceed 4 days. If the defective rail has not been removed from the track or a permanent repair made within 4 days of the discovery, limit operating speed over the defective rail to 30 m.p.h. until joint bars are applied; thereafter, limit speed to 50 m.p.h. or the maximum allowable speed under § 213.9 for the class of track concerned, whichever is lower. When joint bars have not been applied within 10 days, the speed must be limited to 10 m.p.h. until joint bars are applied.*

*D. Apply joint bars bolted only through the outermost holes to the defect within 7 days after it is determined to continue the track in use. In the case of Class 3 through 5 track, limit operating speed over the defective rail to 30 m.p.h. or less as authorized by a person designated under § 213.7(a), who has at least one year of supervisory experience in railroad track maintenance, until joint bars are applied; thereafter, limit speed to 50 m.p.h. or the maximum allowable speed under § 213.9 for the class of track concerned, whichever is lower. When joint bars have not been applied within 7 days, the speed must be limited to 10 m.p.h. until the joint bars are applied.*

*E. Apply joint bars to the defect and bolt in accordance with § 213.121(d) and (e).*

*F. Inspect the rail within 90 days after it is determined to continue the track in use. If the rail remains in the track and is not replaced or repaired, the re-inspection cycle starts over with each successive re-inspection unless the re-inspection reveals the rail defect to have increased in size and therefore become subject to a more restrictive remedial action. This process continues indefinitely until the rail is removed from the track or repaired. If not inspected within 90 days, limit speed to that for Class 2 track or the maximum allowable speed under § 213.9 for the class of track concerned, whichever is lower, until it is inspected.*

*G. Inspect rail within 30 days after it is determined to continue the track in use. If the rail remains in the track and is not replaced or repaired, the re-inspection cycle starts over with each successive re-inspection unless the re-inspection reveals the rail defect to have increased in size and therefore become subject to a more restrictive remedial action. This*

*process continues indefinitely until the rail is removed from the track or repaired. If not inspected within 30 days, limit speed to that for Class 2 track or the maximum allowable speed under § 213.9 for the class of track concerned, whichever is lower, until it is inspected.*

*H. Limit operating speed over the defective rail to 50 m.p.h. or the maximum allowable speed under § 213.9 for the class of track concerned, whichever is lower.*

*I. Limit operating speed over the defective rail to 30 m.p.h. or the maximum allowable speed under § 213.9 for the class of track concerned, whichever is lower.*

113(d) *As used in this section—*

- (1) *Bolt hole crack means a crack across the web, originating from a bolt hole, and progressing on a path either inclined upward toward the rail head or inclined downward toward the base. Fully developed bolt hole cracks may continue horizontally along the head/web or base/web fillet, or they may progress into and through the head or base to separate a piece of the rail end from the rail. Multiple cracks occurring in one rail end are considered to be a single defect. However, bolt hole cracks occurring in adjacent rail ends within the same joint must be reported as separate defects.*
- (2) *Broken base means any break in the base of the rail.*
- (3) *Compound fissure means a progressive fracture originating from a horizontal split head that turns up or down, or in both directions, in the head of the rail. Transverse development normally progresses substantially at a right angle to the length of the rail.*
- (4) *Crushed head means a short length of rail, not at a joint, which has drooped or sagged across the width of the rail head to a depth of  $\frac{3}{8}$  inch or more below the rest of the rail head and 8 inches or more in length. Unlike flattened rail where the depression is visible on the rail head only, the sagging or drooping is also visible in the head/web fillet area.*
- (5) *Damaged rail means any rail broken or otherwise damaged by a derailment, broken, flat, or unbalanced wheel, wheel slipping, or similar causes.*
- (6) *Defective weld means a field or plant weld containing any discontinuities or pockets, exceeding 5 percent of the rail head area individually or 10 percent in the aggregate, oriented in or near the transverse plane, due to incomplete penetration of the weld metal between the rail ends, lack of fusion between weld and rail end metal, entrapment of slag or sand, under-bead or shrinkage cracking, or fatigue cracking. Weld defects may originate in the rail head, web, or base, and in some cases, cracks may progress from the defect into either or both adjoining rail ends. If the weld defect progresses longitudinally through the weld section, the defect is considered a split web for purposes of remedial action required by this section.*
- (7) *Detail fracture means a progressive fracture originating at or near the surface of the rail head. These fractures should not be confused with transverse fissures, compound fissures, or other defects which have internal origins. Detail fractures may arise from shelled spots, head checks, or flaking.*
- (8) *Engine burn fracture means a progressive fracture originating in spots where driving wheels have slipped on top of the rail head. In developing downward these fractures frequently resemble the compound or even transverse fissures with which they should not be confused or classified.*

- (9) *Flattened rail means a short length of rail, not at a joint, which has flattened out across the width of the rail head to a depth of  $\frac{3}{8}$  inch or more below the rest of the rail and 8 inches or more in length. Flattened rail occurrences have no repetitive regularity and thus do not include corrugations, and have no apparent localized cause such as a weld or engine burn. Their individual length is relatively short, as compared to a condition such as head flow on the low rail of curves.*
- (10) *Head and web separation means a progressive fracture, longitudinally separating the head from the web of the rail at the head fillet area.*
- (11) *Horizontal split head means a horizontal progressive defect originating inside of the rail head, usually  $\frac{1}{4}$  inch or more below the running surface and progressing horizontally in all directions, and generally accompanied by a flat spot on the running surface. The defect appears as a crack lengthwise of the rail when it reaches the side of the rail head.*
- (12) *Ordinary break means a partial or complete break in which there is no sign of a fissure, and in which none of the other defects described in this paragraph (d) is found.*
- (13) *Piped rail means a vertical split in a rail, usually in the web, due to failure of the shrinkage cavity in the ingot to unite in rolling.*
- (14) *Split web means a lengthwise crack along the side of the web and extending into or through it.*
- (15) *Transverse fissure means a progressive crosswise fracture starting from a crystalline center or nucleus inside the head from which it spreads outward as a smooth, bright, or dark round or oval surface substantially at a right angle to the length of the rail. The distinguishing features of a transverse fissure from other types of fractures or defects are the crystalline center or nucleus and the nearly smooth surface of the development which surrounds it.*
- (16) *Vertical split head means a vertical split through or near the middle of the head, and extending into or through it. A crack or rust streak may show under the head close to the web or pieces may be split off the side of the head.*

**Guidance:** In paragraph (a), FRA explains that only a person qualified under § 213.7, *Designation of qualified persons certain renewals and inspect track*, is able to determine that a track may continue to be used once a defective condition is identified in a rail. The option “or repaired” is added to paragraph (a)(1) to allow railroads to use recently developed processes to remove the defective portion of the rail section, used normally to remove transverse defects or defective welds, and replace that portion of the rail section by using recently developed weld technologies commonly referred to as “slot welds” or “wide gap welds.” These processes allow the remaining portion of nondefective rail to remain in the track.

FRA redesignated former paragraph (b) (as used in this section) as paragraph (d) and added a new paragraph (b). Paragraph (b) provides that track owners have up to a 4-hour period in which to verify that certain suspected defects exist in a rail section, once they learn that the rail indicates any of the defects identified in paragraph (c)’s remedial action table. This 4-hour, deferred verification period applies only to suspected defects that may require remedial action Notes “C” through “I,” found in the remedial action table. This 4-hour period does not apply to suspected defects that may require remedial action Notes “A,” “A2,” or “B,” which are more serious and must continue to be verified immediately.

The 4-hour timeframe provides flexibility to allow the rail flaw detector car to continue testing in a non-stop mode, without requiring verification of less serious, suspected defects that may require remedial action under notes “C” through “I.” This flexibility also helps to avoid the need to operate the detector car in a non-test, “run light” mode over a possibly severe defective rail condition that could cause a derailment, when having to clear the track for traffic movement. However, any suspected defect encountered that may require remedial action notes “A,” “A2,” or “B” requires immediate verification. Overall, the four-hour, deferred-verification period is intended to help to improve rail flaw detector car utilization, allows operation of the chase car test method, increase the opportunity to detect more serious defects, and ensure that entire rail a detector car is intended to travel over while in service is inspected. The option of “or repaired” is added to paragraph (b)(1) for clarification as stated in paragraph (a) guidance.

FRA added a new paragraph (c) to contain both the remedial action table and its notes, as revised, which formerly were included under paragraph (a). In paragraph (d), three rail defect types are redefined (compound fissure, defective weld, and flattened rail), one is added (crushed head), and all rail flaw definitions are enumerated in alphabetical order. The remedial actions required for defective rails specify definite time limits and speeds.

The remedial actions required for defective rails specify definite time limits and speeds. The remedial actions also allow certain discretion to the track owner for the continued operation over certain defects. Inspectors should consider all rail defects dangerous and care should be taken to determine that proper remedial actions have been accomplished by the track owner of the railroad. When more than one defect is present in a rail, the defect requiring the most restrictive remedial action shall must govern. (Note: In this technical bulletin, FRA’s use of “track owner” or “railroad” is intended to be interchangeable where the railroad is the track owner or otherwise assigned responsibility for compliance under § 213.5).

The remedial action table and specifications in the rule address the risks associated with rail failure. These risks are primarily dependent upon defect type and size and should not be dependent upon the manner or mechanism that reveals the existence of the defect. Failure of the track owner to comply with the operational (speed) restrictions, maintenance procedures, and the prescribed inspection intervals specified in this section and § 213.237 (Defective rails and Inspection of rail, respectively), may result in a violation of the Track Safety Standards (TSS).

Specifically, FRA revised the remedial action table as follows:

- Transverse defects. FRA placed the “transverse fissure” defect in the same category as detail fracture, engine burn fracture, and defective weld because they all normally fail in a transverse plane.
- Compound fissure remains with the same remedial action classifications. This type of defect has an increased potential to fail in an oblique plane and is considered a more serious defect.
- FRA changed the heading of the remedial action table for all transverse-type defects (i.e., compound fissures, transverse fissures, detail fractures, engine burn fractures, and defective welds) to refer to the “percentage of existing rail head cross-sectional area weakened by defect,” to indicate that all transverse defect sizes are related to

the actual rail head cross-sectional area. Additionally “or repaired” is added to the heading in the table.

- FRA reduced the cross-sectional area of the rail head which requires remedial action. Notes “A2” or “E and H” to 60 percent from the prior limit of 80 percent.
- FRA added a required remedial action and definition for a longitudinal defect that is associated with a defective weld—longitudinal.
- FRA added “crushed head” to the remedial action table and defect definition.
- Footnote 1 reminds inspectors that a chipped rail end is not a designated rail defect under this section and is not, in itself, an FRA-enforceable defective condition. Inspectors are reminded that a chipped rail end is not to be considered as a “break out in rail head.”
- Footnote 2 provides that remedial action Note “D” applies to a moon-shaped breakout, resulting from a derailment, with a length greater than 6 inches but not exceeding 12 inches and a width not exceeding one-third of the rail base width. FRA also recommends that track owners conduct a special visual inspection of the rail pursuant to § 213.239, before the operation of any train over the affected track. A special visual inspection pursuant to § 213.239, which requires that an inspection be made of the track involved in a derailment incident, should be done to assess the condition of the track associated with these broken base conditions before the operation of any train over the affected track.

Note “A” clarifies that a person qualified to supervise certain renewals and inspect track as designated in § 213.7 must visually supervise each operation over the defective rail.

Note “A2” addresses mid-range transverse defect sizes. This remedial action allows for train operations to continue at a maximum of 10 mph up to 24 hours, following a visual inspection by a person designated under § 213.7. If the rail is not repaired or replaced, another 24-hour cycle begins.

Note “B” limits speed to that as authorized by a person designated under § 213.7(a) who has at least 1 year of supervisory experience in track maintenance. The qualified person has the responsibility to evaluate the rail defect and authorize the maximum operating speed over the defective rail based on the size of the defect and the operating conditions; however, the maximum speed over the rail may not exceed 30 mph or the maximum speed under § 213.9 for the class of track concerned (whichever is lower).

Notes “C,” “D,” and “H” limit the operating speed, following the application of joint bars, to 50 mph or the maximum allowable speed under § 213.9 for the class of track concerned (whichever is lower). When the maximum speed specified in Notes “B,” “C,” “D,” and “H” exceeds the current track speed, the railroad is required to record the defect. For example, when a railroad determines that remedial action Note “B” is required and the track speed already is 30 mph or less, the railroad must record the defect. This indicates that the railroad is aware of the characteristics of the defective rail and has designated a permissible speed in compliance with the regulation.

Note “C” applies specifically to detail fractures, engine burn fractures, transverse fissures, and defective welds, and addresses defects that are discovered during an internal rail

inspection required under § 213.237 and whose size is determined not to be in excess of 25 percent of the rail head cross-sectional area. For these specific defects, a track owner formerly had to apply joint bars bolted only through the outermost holes at the defect location within 20 days after it had determined to continue the track in use.

Note “C” is revised for these specific defects and now requires a track owner to apply joint bars bolted only through the outermost holes to the defect within 10 days after it is determined to continue the track in use. When joint bars have not been applied within 10 days, the track speed must be limited to 10 mph until joint bars are applied. This addition allows the railroads alternative relief from remedial action for these types of defects in Class 1 and 2 track.

Note “D” applies specifically to detail fractures, engine burn fractures, transverse fissures, and defective welds, and addresses defects that are discovered during an internal rail inspection required under § 213.237 and whose size is determined not to be in excess of 60 percent of the rail head cross-sectional area. Formerly, for these specific defects, a track owner had to apply joint bars bolted only through the outermost holes at the defect location within 10 days after it is determined that the track should continue in use.

Note “D” is revised for these specific defects and now requires a track owner to apply joint bars bolted only through the outermost holes to the defect within 7 days after it is determined to continue the track in use. The allowance of 7 days provides the track owner with additional time for remediation when the defect is identified just prior to the start of weekend shutdown. When joint bars have not been applied within 10 days, the track speed must be limited to 10 mph until joint bars are applied. As mentioned in Note “C,” this addition also allows the railroads alternative relief from remedial action for these types of defects in Classes 1 and 2 track.

When an FRA inspector discovers a defective rail that requires the railroad representative to determine whether to continue the track in use and to designate the maximum speed over the rail, the inspector should inquire as to the representative’s knowledge of the defect and remedial action. If the railroad was not aware of the defect prior to the FRA inspection, the FRA inspector should observe the actions taken by the railroad representative to determine compliance. If the railroad had previously found the defective rail, the FRA inspector should confirm the proper remedial action was taken. During records inspections, the FRA inspector should confirm that the defects were recorded and proper remedial actions were taken.

The remedial action table for defects failing in the transverse plane (transverse and compound fissures, detail and engine burn fractures, and defective welds) specifies a lower limit range base of 5 percent of the railhead cross-sectional area. If a transverse defect is reported to be less than 5 percent, the track owner is not legally bound to provide corrective action under the TSS. Conditions reported to be less than 5 percent are not consistently found during rail breaking routines and therefore, defect determination within this range is not always reliable.

Compound fissure defects that weaken between 5 and 70 percent of cross-sectional of the rail head area are defects requiring remedial action (Note B). Defects in the range between 70 and less than 100 percent of cross-sectional head area require remedial action (Note A2), as prescribed. Defects that affect 100 percent of the cross-sectional head area require

remedial action (Note A) as prescribed, the most restrictive remedial actions. Inspectors should be aware that compound fissures are defects that can fail in the transverse or oblique plane and are characteristic of rail that has not been control-cooled (normally rolled prior to 1936).

Defects identified and grouped as detail fractures, engine burn fractures, transverse fissures, and defective welds, will weaken and will normally fail in the transverse plane. Detail fractures are characteristic of control-cooled rail [usually indicated by the letters CC or CH on the rail brand (i.e., 1360 RE CC CF&I 1982 1111)]. Their prescribed remedial action relates to a low range between 5 and 25 percent and a mid-range between 25 and 60 percent, for Notes “C” and “D,” respectively. Those defects require joint bar applications and operational speed restrictions within certain time frames. Defects extending less than 100 and more than 60 percent require a visual inspection. If the rail is not replaced, effectively repaired, or removed from service, an elective would be to restrict operation to a maximum of 10 mph for up to 24 hours, then perform another visual inspection.

The second sentence in remedial action Note “C” addresses defects that are discovered in Classes 3 through 5 track during an internal rail inspection required under § 213.237, and which are determined not to be in excess of 25 percent of the rail head cross-sectional area. For these specific defects, a track owner may operate for a period not to exceed 4 days, at a speed limited to 50 mph or the maximum allowable speed under § 213.9 for the class of track concerned, whichever is lower. If the defective rail is not removed or a permanent repair is not made within 4 days of discovery, the speed is limited to 30 mph, until joint bars are applied or the rail is replaced.

The requirements specified in this second paragraph are intended to promote better usage of rail inspection equipment and therefore maximize the opportunity to discover rail defects, which are approaching service failure size. The results of FRA’s research indicate that defects of this type and size range have a predictable slow growth life. Research further indicates that even on today’s most heavily used trackage in use today, defects of this type and size are unlikely to grow to service failure size in 4 days.

In the remedial action table, all longitudinal defects are combined within one group subject to identical remedial actions based on their reported size. These types of longitudinal defects all share similar growth rates and the same remedial actions are appropriate to each type.

Defective rails categorized as horizontal split head, vertical split head, split web, piped rail, and head-web separation, and defective weld (longitudinal) are longitudinal in nature. When any of this group of defects is more than 1 inch, but not more than 2 inches, the remedial action initiated, under Note “H,” is to limit train speed to 50 mph, and Note “F” requires re-inspecting the rail in 90 days, if deciding operations will continue. If not inspected within 90 days, limit speed to that for Class 2 track or the maximum allowable speed under § 213.9 for the class of track concerned, whichever is lower, until it is inspected. Defects in the range of more than 2 inches, but not more than 4 inches, require complying with Notes “I” and “G,” speed is limited to 30 mph and the rail re-inspected in 30 days, if they decide operations will continue. If not inspected within 30 days, speed is limited to that for Class 2 track or the maximum allowable speed under § 213.9 for the class of track concerned, whichever is lower, until it is inspected. When any of the six defect

types exceed a length of 4 inches, a person designated under § 213.7(a) must limit the operating speed to 30 mph, under Note “B.”

Another form of head-web separation, often referred to as a “fillet cracked rail,” is the longitudinal growth of a crack in the fillet area, usually on the gage side of the outer rail of a curve. The crack may not extend the full width between the head and the web, but it is potentially dangerous. Evidence of fillet cracking is a hairline crack running beneath the head of rail with “bleeding” or rust discoloration. Fillet cracks often result from improper super-elevation or from stress reversal as a result of transposing rail. The use of a mirror is an effective aid in examining rail and the determination of head-web cracks or separation in the body of the rail.

A “bolt hole crack” is a progressive fracture originating at a bolt hole and extending away from the hole, usually at an angle. It develops from high stress risers, usually initiating as a result of both dynamic and thermal responses of the joint bolt and points along the edge of the hole, under load. A major cause of this high stress is improper field drilling of the hole. Excessive longitudinal rail movement can also cause high stress along the edge of the hole. When evaluating a rail end, which has multiple bolt hole cracks, inspectors will determine the required remedial action based on the length of the longest individual bolt hole crack.

Under Notes “H” and “F”, the remedial action for a bolt hole crack that is more than one-half of an inch, but not more than 1 inch, if the rail is not replaced—is to limit speed to 50 mph, or the maximum allowable under § 213.9 for the class of track concerned, whichever is lower, then re-inspect the rail in 90 days, if operations will continue.

For bolt hole cracks greater than 1 inch, but not exceeding 1½ inches, Notes “H” and “G” apply. These rails are required to be limited to 50 mph and re-inspected within 30 days. For a bolt hole crack exceeding 1½ inches, a person qualified under § 213.7(a) may elect to designate a speed restriction, which cannot exceed 30 mph, or the maximum allowable under § 213.9 for the class of track concerned, whichever is lower.

Under Notes “F” and “G,” where corrective action requires rail to be re-inspected within a specific number of days after discovery, several options for compliance may be exercised depending on the nature of the defect. For those defects that are strictly internal and are not yet visible to the naked eye, the only option would be to perform another inspection with rail flaw detection equipment, either rail-mounted or hand-held. For defects that are visible to the naked eye and therefore measurable, a visual inspection or an inspection with rail flaw detection equipment are acceptable options. For certain defects enclosed within the joint bar area, such as bolt hole cracks and head-web separations, the joint bars must be removed if a visual re-inspection is to be made.

The re-inspection prescribed in Notes “F” and “G” must be performed prior to the expiration of the 30- or 90-day interval. If the rail remains in track and is not replaced or repaired, the re-inspection cycle starts over with each successive re-inspection unless the re-inspection reveals that the rail defect to have increased in size, and has therefore become subject to a more restrictive remedial action. This process continues indefinitely until the rail is removed from track or repaired.

Where corrective action requires rail to be re-inspected within a specific number of days after discovery, the track owner may exercise several options for compliance. One option



would be to perform another inspection with rail flaw detection equipment, either rail-mounted or hand-held. Another option would be to perform a visual inspection where the defect is visible and measurable. In the latter case, for certain defects enclosed within the joint bar area such as bolt hole breaks, removal of the joint bars will be necessary to comply with the re-inspection requirement. If not inspected within 30- or 90-day timelines, limit speed to that for Class 2 track or the maximum allowable speed under § 213.9 for the class of track concerned, whichever is lower, until it is inspected. This change defines the re-inspection cycle and requires the track owner to continue the re-inspection or apply a reduction in speed.

If defects remain in track beyond the re-inspection interval, the railroad must continue to monitor the defects and take the appropriate actions as required in the remedial action table.

A broken base can result from improper bearing of the base on a track spike or tie plate shoulder, and from overcrimped anchors, or it may originate in a manufacturing flaw. With today's higher axle loads, inspectors can anticipate broken base defects in 75-pound, and smaller, rail sections with an irregular track surface, especially on the field side. For any broken base discovered that is more than 1 inch, but less than 6 inches in length, the remedial action (Note D) is to apply joint bars bolted through the outermost holes to defect within 10 days, if operations will continue. In Classes 3 through 5 track, the operating speed must be reduced to 30 mph or less, as authorized by a person under § 213.7(a), until joint bars are applied. After that, operating speed is limited to 50 mph or the maximum allowable under § 213.9 for the class of track concerned, whichever is lower.

Under Note "D," there are several acceptable "outermost hole" bolting arrangements for joint bars centered on a rail defect. See Figure 1 for an illustration of acceptable bolting arrangements. In all cases, railroads may not drill a bolt hole next to a defect that is being remediated with the application of joints bars (pursuant to Note D). The reason for not drilling next to the defect is to prevent the propagation of the crack into the hole closest to the defect.

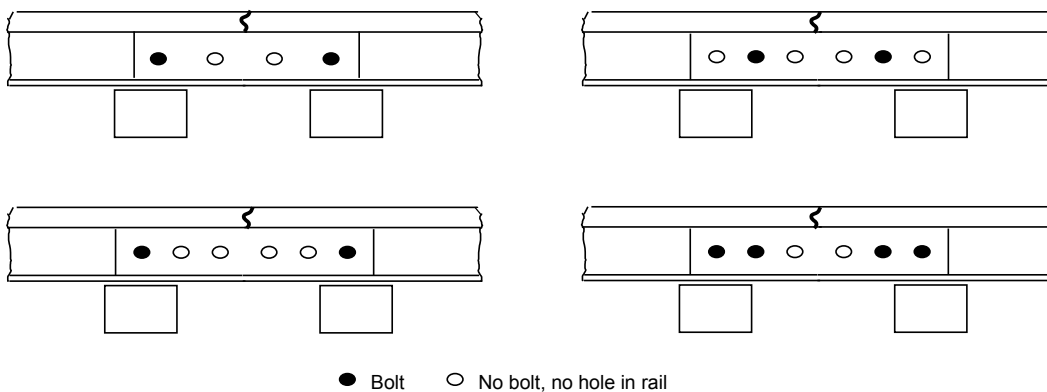

**Figure 1**

A broken base in excess of 6 inches requires the assignment of a person designated under § 213.7 to visually supervise each train operation over the defective rail. The railroad may

apply joint bars to the defect and bolt them in accordance with §§ 213.121(d) and (e), and thereafter must limit train operations to 30 mph or the maximum allowable under § 213.9 for the class of track concerned, whichever is lower. As reference, the dimensions between the outermost holes of a 24-inch joint bar vary between approximately 15 and 18 inches, and a 36-inch joint bar approaches 30 inches.

Inspectors should point out to the track owner that broken bases nearing these dimensions may negate the purpose for which the joint bars are applied. A broken base rail may be caused by damage from external sources, such as rail anchors being driven through the base by a derailed wheel. It is improper to consider them “damaged rail,” as this defect is addressed by more stringent provisions applicable to broken base rails, under Note “A” or “E” and “I.”

Damaged rail can result from flat or broken wheels, incidental hammer blows, or derailed or dragging equipment. Reducing the operational speed in Classes 3 through 5 track to 30 mph until joint bars are applied, lessens the impact force imparted to the weakened area. Applying joint bars under Note “D” ensures a proper horizontal and vertical rail end alignment in the event the rail fails.

Flattened rails and crushed rails (localized collapsed head rail) are also caused by mechanical interaction from repetitive wheel loadings. FRA and industry research indicate that these occurrences are more accurately categorized as rail surface conditions, not rail defects, as they do not, in themselves, cause service failure of the rail. Although it is not a condition shown to affect the structural integrity of the rail section, it can result in less than desirable dynamic vehicle responses in the higher speed ranges. The flattened rail condition is identified in the table, as well as in the definition portion of § 213.113(b), as being three-eighths of an inch or more in depth below the rest of the rail head and 8 inches or more in length. As the defect becomes more severe by a reduced rail head depth, wheel forces increase.

The rule addresses flattened rail in terms of a specified remedial action for those of a certain depth and length. Those locations meeting the depth and length criteria must be limited to an operating speed of 50 mph or the maximum allowable under § 213.9 for the class of track concerned, whichever is lower.

“Break out in rail head” is defined as a piece that has physically separated from the parent rail. Rail defects meeting this definition are required to have each operation over the defective rail visually supervised by a person designated under § 213.7. Inspectors need to be aware that this definition has applicability across a wide range of rail defects, as indicated in the Remedial Action Table. Where rail defects have not progressed to the point where they meet the definition of a break out, but due to the type, length, and location of the defect, they present a hazard to continued train operation, inspectors should determine what remedial actions, if any, track owner should institute.

The following are two rail head break out examples where the Note “A” corrective action would be necessary:

- Example One: A bolt hole break where the head of the rail is totally separated from the parent rail (either tight or loose), but that piece of rail will not physically lift out of the joint bars by hand. The inspector might determine that the separation was total

because the separated piece rattled when tapped. It is important that railroads take the appropriate remedial action in this situation, because it is potentially very unsafe. It is impossible to know what will happen when the next train operates over this defect. That train could cause the piece to become so loose that it comes out of the place, cocks at an angle and causes a wheel to ramp up, derailing the train.

- Example Two: A vertical split head defective rail where rail head separation is apparent because the inspector can determine that a physical separation has occurred through the rail head, but the rail head has not entirely separated over the entire length of the defect.

The following is an example where the Note “A” corrective action would not be necessary:

- Example: At rail joints, a chipped rail end is not considered a rail defect according to the current § 213.113 table, and should not be considered as a break out in the rail head.

The issue of “excessive rail wear” continues to be evaluated by the Rail Integrity Task Force. FRA believes that insufficient data exists at this time to indicate that parameters for this condition should be proposed as a minimum standard.

Some railroads apply safety “weld straps” to thermite type field welds. These straps do not provide the same support of a joint bar. They would provide only limited support if a weld were to break under a train movement and as such, they do not comply with the provisions of corrective actions C, D, or E (installation of joint bars). Only a joint bar having full contact with the bottom of the rail head and rail base [see § 213.121 (a)] and with a manufactured relief for the weld material would comply with corrective actions C, D, or E.

When an FRA inspector finds a rail defect that appears to originate from fatigue at a bond wire attachment weld, the inspector should cite the railroad for 213 defect code 0113B. Inspectors must also identify in their narrative the type of the rail defect (e.g., defective weld, detail fracture, etc.). FRA added this defect code based on a National Transportation Safety Board (NTSB) recommendation arising from the NTSB investigation of a February 9, 2003, Canadian National Railway (CN) derailment in Tamaroa, Illinois. The NTSB determined that the probable cause of this accident was CN’s placement of bond wire welds on the head of the rail just outside the joint bars, where untempered martensite associated with the welds led to fatigue cracking that, because of increased stresses associated with known soft ballast conditions, rapidly progressed to rail failure.

FRA provides the Track Inspector Rail Defect Reference Manual on the e-library in its Web site. Inspectors are expected to be conversant with rail defect types, appearance, growth, hazards, and methods of detection.

**§ 213.115 Rail end mismatch**

*Any mismatch of rails at joints may not be more than that prescribed by the following table –*

	<b><i>Any mismatch of rails at joints may not be more than the following-</i></b>
--	---

<b>Class of track</b>	<b>On the tread of the rail ends (inch)</b>	<b>On the gage side of the rail ends (inch)</b>
1	$\frac{1}{4}$	$\frac{1}{4}$
2	$\frac{1}{4}$	$\frac{3}{16}$
3	$\frac{3}{16}$	$\frac{3}{16}$
4 and 5	$\frac{1}{8}$	$\frac{1}{8}$

**Guidance:** Use a straightedge to determine the mismatch by holding the straightedge longitudinally along the higher rail (tread) or along the gage side (five-eighths inch down from the running surface) of the rail. Measure the distance directly between the straightedge and the rail. Disregard plastic overflow (gage side rail edge lipping), if any.

One example of mismatch occurs when a section of a rail is placed in the track where the existing rail head is gage- and/or treadworn. Mismatch can also occur when the joint bars are loose. However, if the loose bars do not result in mismatch exceeding the thresholds under this section, report the defect as loose joint bars (see § 213.121).

The standards prescribe both tread and gage mismatch thresholds. A mismatch may result in high impact forces especially at higher speeds. If a mismatch in excess of the allowable results in significant rail end damage, a violation should be considered.

Particular attention should be given to the mismatch on the gage side of a rail. A thin flange, skewed truck, or combination of both may cause a wheel to climb, particularly on the outer rail of a curve. The following figure shows the proper method to measure gage and tread mismatch.

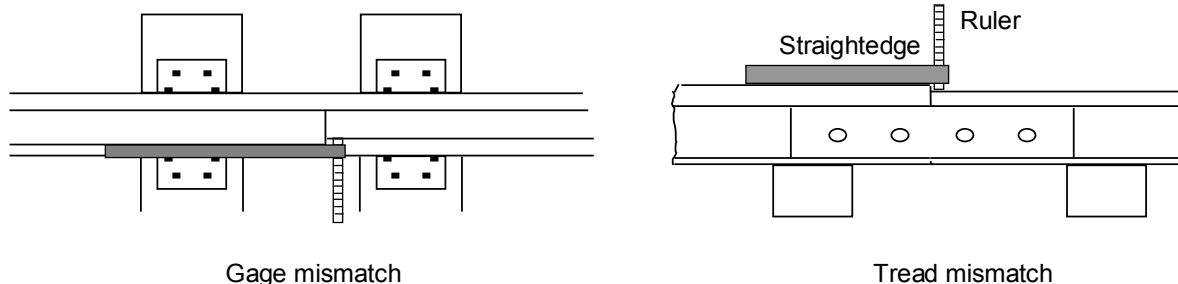

### **§ 213.118 Continuous welded rail (CWR); plan review and approval.**

118(a) Each track owner with track constructed of CWR shall have in effect and comply with a plan that contains written procedures which address: the installation, adjustment, maintenance, and inspection of CWR; inspection of CWR joints; and a training program for the application of those procedures.

118(b) The track owner shall file its CWR plan with the FRA Associate Administrator for Railroad Safety/Chief Safety Officer (Associate Administrator). Within 30 days of receipt of the submission, FRA will review the plan for compliance with this subpart. FRA will approve, disapprove or conditionally approve the submitted plan, and will provide written notice of its determination.

*118(c) The track owner's existing plan shall remain in effect until the track owner's new plan is approved or conditionally approved and is effective pursuant to paragraph (d) of this section.*

*118(d) The track owner shall, upon receipt of FRA's approval or conditional approval, establish the plan's effective date. The track owner shall advise in writing FRA and all affected employees of the effective date.*

*118(e) FRA, for cause stated, may, subsequent to plan approval or conditional approval, require revisions to the plan to bring the plan into conformity with this subpart. Notice of a revision requirement shall be made in writing and specify the basis of FRA's requirement. The track owner may, within 30 days of the revision requirement, respond and provide written submissions in support of the original plan. FRA renders a final decision in writing. Not more than 30 days following any final decision requiring revisions to a CWR plan, the track owner shall amend the plan in accordance with FRA's decision and resubmit the conforming plan. The conforming plan becomes effective upon its submission to FRA.*

**Guidance:** All CWR plans must be submitted to FRA for review by the Track Division and then approval by the Associate Administrator for Railroad Safety/Chief Safety Officer. FRA reviews each plan for compliance with §§ 213.119(a) through (l). Regional track specialists may be requested to provide recommendations concerning the comprehensiveness of those procedures.

When conducting track inspections, an FRA inspector should have with him the most recent copy of a railroad's CWR plan. This is important because it will enable the inspector to perform a proper inspection and determine compliance with the plan. Finalized CWR plans are posted on the FRA secured Web site for the inspector's review and enforcement. If an inspector discovers substantial discrepancies between the official plan on file at FRA headquarters and the plan in the field (or that there are substantial discrepancies between the official plan on file with FRA and a railroad field manual), the inspector should notify the regional Track specialist.

FRA may also conditionally approve a plan. There might be instances where it would be beneficial for the agency to conditionally approve a plan. For example, FRA might decide that a plan should be approved, but might need to look into new technology proposed in the plan. FRA reserves the ability to later approve or disapprove a plan that it has formally conditionally approved.

A track owner may update or modify CWR procedures as necessary, but must resubmit any new or modified plan to FRA pursuant to § 213.118. Until the new plan is approved or conditionally approved and effective pursuant to paragraph (d), the track owner's existing plan will remain in effect.

### **§ 213.119 Continuous welded rail (CWR); plan contents.**

**Guidance, General:** In addition to safety-critical procedures listed in this section, the railroad may decide to include procedures based on administrative or economic considerations. For example, a railroad may choose to include instructions that limit the use of worn secondhand replacement rail because of an economic concern about the length of time that it might take to perform a satisfactory weld. The railroad may also include specific actions in their procedures that are to be taken when installation or maintenance work does not comply with its overall procedures.

Recording an activity that does not conform to the railroad's CWR procedures does not provide the railroad with indefinite relief from responsibility for compliance when its procedures are not followed. Continued noncompliance may lead to an unsafe condition. The recordkeeping procedure is intended to provide a safety net by flagging those activities of noncompliance, which, if not brought into compliance in a timely manner, could lead to an unsafe condition. For example, CWR installed in the winter months without adequate rail anchors as prescribed by the written procedures and discovered in late summer would clearly be a deficient condition, regardless of if it was recorded. When in doubt as to what activities are considered safety related, the inspector should consult with the regional Track specialist.

Whenever conducting inspections on a railroad and that activity includes observation of CWR, FRA inspectors are to include only one "CWRP" unit on the header of their Railroad Inspection System for Personal Computers (RISPC) inspection report. Record one CWRP unit, regardless of the amount of CWR mileage inspected. Record the actual track mileage units using the activity codes MTH, MTW, etc. When a defect is taken for any aspect of § 213.119, FRA inspectors are to also designate CWRP for the line item "activity" cell. In addition, inspectors are to use CWRP in each line item activity cell when performing records inspections and recording deficiencies concerning CWR joint records.

The definition of a "buckling incident" explains the industry definition for such an event. However, the rule recognizes the importance of conditions that are precursors to buckles.

The two failure modes associated with track constructed with CWR are track buckles and pull-aparts. A track buckle is considered the more serious of the two and is characterized by the formation of a large lateral misalignment caused by:

- High compressive forces in the rail (thermal and mechanical loads).
- Weakened track conditions (weak track resistance, alinement deviations).
- Vehicle loads (a dynamic "wave" uplift and lateral vs. vertical ratios).

*The track owner shall comply with the contents of the CWR plan approved or conditionally approved under § 213.118. The plan shall contain the following elements—*

*119(a) Procedures for the installation and adjustment of CWR which include—*

- (1) Designation of a desired rail installation temperature range for the geographic area in which the CWR is located; and*
- (2) De-stressing procedures/methods which address proper attainment of the desired rail installation temperature range when adjusting CWR.*

**Guidance:** Track owners with track constructed of CWR are required to have in effect and comply with a CWR plan. This includes track owners who operate entirely on CWR track that has been designated as excepted track, pursuant to § 213.4. The procedures under § 213.119 do not apply to excepted track. (See § 213.5(b)). However, where a railroad designates a segment of track as excepted, it still must meet the requirements of at least Class 1 track for any portion of that track that is: (1) located within 30 feet of an adjacent track that is subjected to simultaneous use at speeds in excess of 10 mph, or (2) located on a bridge or on a public street or highway and there are trains with placarded cars. (See § 213.4(d))

Railroads typically establish a desired rail installation temperature range for the geographical area that is higher than the annual mean temperature. This higher installation temperature will account for the expected reduction of the force-free temperature caused by track maintenance, train traffic, and other factors. As reference, the term for this expected occurrence is “rail neutral temperature shift.” A railroad’s failure to establish a designated installation temperature range for a specific territory is addressed under § 213.119(a).

*119(b) Rail anchoring or fastening requirements that will provide sufficient restraint to limit longitudinal rail and crosstie movement to the extent practical, and specifically addressing CWR rail anchoring or fastening patterns on bridges, bridge approaches, and at other locations where possible longitudinal rail and crosstie movement associated with normally expected train-induced forces, is restricted.*

*119(c) CWR joint installation and maintenance procedures which require that—*

*(1) Each rail shall be bolted with at least two bolts at each CWR joint;*

**Guidance:** The track inspector should determine that any joints installed in CWR or connecting to CWR must have at least two bolts in each rail end, a minimum of four bolts installed in the joint bars, if not field welded at the time of installation. § 213.121(e).

This requirement serves as a reminder to track owners that they cannot create their own joint bolt requirements in their CWR plans that are less restrictive than those specified in the TSS.

*(2) In the case of a bolted joint installed during CWR installation after October 21, 2009, the track owner shall either, within 60 days—*

*(i) Weld the joint;*

*(ii) Install a joint with six bolts; or*

*(iii) Anchor every tie 195 feet in both directions from the joint; and*

**Guidance:** This section applies to major installations of CWR, such as more than 400 feet. It is not intended for plug rails. Note that the applicability date published in the final rule for this section (August 25, 2009) was corrected via the amendment published on October 21, 2009, at 74 FR 53889.

*(3) In the case of a bolted joint in CWR experiencing service failure or a failed bar with a rail gap present, the track owner shall either—*

**Guidance:** This section addresses CWR joints that experience a failure with a rail gap present. The definition for rail gap for this section is that the rail is under tension. An example of a joint failure under tension is a joint where the rail ends could not be pulled back together manually, as with the use of a drift pin, or if mechanical or thermal assistance is needed. A remedial action from § 213.119(c)(3) must be taken. Check for evidence of tension (such as bent and broken bolts) or application of thermal force (heat from repair rope, sawdust, or flammable mix).

*(i) Weld the joint;*

**Guidance:** The rail is welded at the time the joint is repaired.

*(ii) Replace the broken bar(s), replace the broken bolts, adjust the anchors and, within 30 days, weld the joint;*

**Guidance:** The 30-day time limit is only to allow the railroad adequate time to gather resources to weld the joint. If a CWR joint becomes battered before a repair can be completed and the track owner decides to cut in a plug rail to remove the battered joint, the track must immediately be brought into compliance as specified in § 213.121(e). The 30-day time limit starts from the original joint installation date for both joints. The remedial action 30-day period does not begin again when both CWR rail joints are required to be removed. If the joints have not been welded on the 31st day, a violation may be submitted to the track owner for failure to take the appropriate remedial action. The track owner must have selected the planned remedial action to be taken on the inspection report or other documentation that may be addressed in the CWR plan at the time the defect was discovered, and it must be documented. This written or electronic documentation must be made available upon request by FRA during regular business hours.

*(iii) Replace the broken bar(s), replace the broken bolts, install one additional bolt per rail end, and adjust anchors;*

*(iv) Replace the broken bar(s), replace the broken bolts, and anchor every tie 195 feet in both directions from the CWR joint; or*

*(v) Replace the broken bar(s), replace the broken bolts, add rail with provisions for later adjustment pursuant to paragraph (d)(2) of this section, and reapply the anchors.*

**Guidance:** The track owner should ensure that any rail added during the repair of a CWR pull-apart is properly adjusted back to the required safe neutral temperature in accordance with the railroad's CWR plan. As the rail temperature rises, the expansion of rail increases. The track owner must have provisions in the CWR plan to slow order the affected track and make repairs and adjustment to bring the track into compliance. For example, in many cases, the addition of 1 inch of rail in a 1,000-foot string of CWR will lower its rail neutral temperature by 13 degrees.

If the remedial actions, described in §§ 213.119(c)(iii), (iv), or (v); are used and the affected joint fails again (with a rail gap present after the initial repair), additional, more restrictive repairs are required. This shows that the rail tension was not adequately addressed during the initial remedial action. CWR joints must be inspected for compliance with additional parts of the TSS, such as tie condition, surface, rail end mismatch, and properly fitting joint bars.

*119(d) Procedures which specifically address maintaining a desired rail installation temperature range when cutting CWR including rail repairs, in-track welding, and in conjunction with adjustments made in the area of tight track, a track buckle, or a pull-apart. Rail repair practices shall take into consideration existing rail temperature so that—*

*(1) When rail is removed, the length installed shall be determined by taking into consideration the existing rail temperature and the desired rail installation temperature range; and*

*(2) Under no circumstances should rail be added when the rail temperature is below that designated by paragraph (a)(1) of this section, without provisions for later adjustment.*

*119(e) Procedures which address the monitoring of CWR in curved track for inward shifts of alignment toward the center of the curve as a result of disturbed track.*

**Guidance:** Thermal and mechanical loads affecting track structure are decreased by the track owner's adherence to the track engineering standards. Adherence to the track owner's standards and the CWR plan promote CWR track stability and safety. Three



engineering elements resist mechanical loads and thermal loads: lateral resistance, longitudinal resistance, and rail neutral temperature. Track buckles can be expected to occur predominately in the lateral dimension. Lateral resistance is critical to being dependent upon weight and size of crosstie material, ballast material type, shoulder width, crib content, and its level of consolidation. As degree of curvature increases, the buckling resistance decreases. A crosstie's base, side (crib) friction, and ballast shoulder resistance contribute to the overall lateral resistance sustained. In general, each contributes (base 50 percent, side 20–30 percent, and shoulder 20–30 percent) to this resistance, but the ratios can vary depending on ballast condition. Lateral resistance varies in location depending on the ballast shoulder geometry, crosstie size and type, and state of ballast consolidation.

Thermal loads, by themselves, can cause a buckle and are often called “static buckling.” However, most buckling occurs under a combination of thermal and vehicle loads, termed “dynamic buckling.” Inspectors should place emphasis on vehicle (dynamic) effects on track lateral stability, where high rail temperatures and vehicle loading could progressively weaken the track due to dynamic uplift (flexural waves) and a buckle mechanism response induced by misalignment “growth.”

Because the majority of buckles occur under dynamic train movements, loading is an important element in the buckling mechanism. Elements of track lateral instability include:

- Formation of initial track misalignment caused by reduced local resistance.
- High impact loads, initial rail surface (weld) imperfections, “soft” spots in ballast, and curve (radial breathing) shifting.
- Misalignment growth caused by high lateral loads, increased longitudinal forces, track uplifts due to vertical loads, and train-induced vibration.

Inspectors may consider the above elements, combined with related evidence of actual defects, geometry conditions, or other defective structural conditions, when evaluating the adequacy of a railroad's CWR stability procedures under §§ 213.119(b), (c), (d), and (e).

Locations where track buckling are more likely to occur include: horizontal and vertical curves, bottom of grades, bridge approaches, highway-rail grade crossings, recently-disturbed track, and areas of heavy train starting or braking.

The signs or precursors of buckles include:

- Newly formed alinement deviations: wavy, kinky, snaky, etc.
- Rails rotating or lifting out of the tie plates and intermittent loose tie plates.
- Excessive “running” rail causing ties to plow or churn the ballast.
- Insufficient anchors and anchors not installed tightly against the tie.
- Insufficient ballast section in the crib and shoulder areas.
- Gaps at crosstie ends, especially on the low (inner) rail.

Curves are more prone to buckling because of the curvature effect, alinement imperfection sensitivity, and train loads. It is important for inspectors to consider when and where a buckle may occur (e.g., on track segments where the CWR installation occurred below the desired rail installation temperature range and there was inadequate control of the laying temperature or inadequate adjustment of the rail afterwards). In addition, inspectors should observe areas of recent maintenance involving either the ballast or rail, where there was inadequate reconsolidating time for a disturbed ballast or inadequate temperature adjustment when replacing a defective rail. As curvature increases, the buckling resistance decreases. Under some conditions, high degree curvature can undergo gradual lateral shift (progressive buckling). Lateral alinement deviations reduce the track buckling strength and

can initiate growth to critical levels. Vertical alignment deviations can also influence buckling.

Lateral misalignment is an important consideration because it reduces the ability of the track to resist buckling. An alignment offset or mid-ordinate within allowable limits may “escalate” under the imposed loads. This is called “track shift.” A longitudinal force in curved track will cause CWR rail to move radically. Compressive loads in the rail during the summer tend to move the track outwards, and tensile loads in the winter will pull the track inward, a term known as “radial breathing.” Inspectors should review the allowable limits, under § 213.55, and evaluate the relevant alignment and track strength (§ 213.13, Movement under load) due to repeated thermal and vehicle loadings.

Generally speaking, a decrease in the rail neutral temperature of 30–40 degrees from the installation temperature can be critical and lead directly to buckling. Inspectors should monitor the following factors that may influence shifts in the force-free temperature: improper rail installation, inadequate rail anchors or fastenings, lateral movements in curves through lining operations, “skeletonized” track segments (ballast removed for maintenance purposes), and inadequate ballast section. Lateral and longitudinal restraint is influenced by the factors mentioned above and, if improperly maintained or allowed to exist in a defective state, it increases the opportunity for a track buckle.

Track buckles occur less frequently in tangent track than in curves. However, buckling in tangent track will generally occur suddenly and with more severe consequences.

The second of the two failure modes that can be associated with track constructed with CWR is a pull-apart. A rail’s decrease in temperature in the winter will create tensile forces. The maximum tensile load in the rail is determined by the difference in the installation or force-free temperature and the lowest rail temperatures. Enough tensile force can cause direct fracture at rail cross-sections with prior cracks, weak welds, or sheared joint bolts at CWR string end locations.

*119(f) Procedures which govern train speed on CWR track when—*

- (1) Maintenance work, track rehabilitation, track construction, or any other event occurs which disturbs the roadbed or ballast section and reduces the lateral or longitudinal resistance of the track; and*
- (2) The difference between the average rail temperature and the average rail neutral temperature is in a range that causes buckling-prone conditions to be present at a specific location; and*

**Guidance:** This requires that the railroad needs to record the new rail neutral temperature when performing rail repair and installation.

- (3) In formulating the procedures under paragraphs (f)(1) and (f)(2) of this section, the track owner shall—*
  - (i) Determine the speed required, and the duration and subsequent removal of any speed restriction based on the restoration of the ballast, along with sufficient ballast re-consolidation to stabilize the track to a level that can accommodate expected train-induced forces. Ballast re-consolidation can be achieved through either the passage of train tonnage or mechanical stabilization procedures, or both; and*

*(ii) Take into consideration the type of crossties used.*

*119(g) Procedures which prescribe when physical track inspections are to be performed.*

*(1) At a minimum, these procedures shall address inspecting track to identify—*

*(i) Buckling-prone conditions in CWR track, including—*

*(A) Locations where tight or kinky rail conditions are likely to occur; and*

*(B) Locations where track work of the nature described in paragraph (f)(1)(i) of this section has recently been performed; and*

*(ii) Pull-apart prone conditions in CWR track, including locations where pull-apart or stripped-joint rail conditions are likely to occur; and*

*(2) In formulating the procedures under paragraph (g)(1) of this section, the track owner shall—*

*(i) Specify when the inspections will be conducted; and*

*(ii) Specify the appropriate remedial actions to be taken when either buckling-prone or pull-apart prone conditions are found.*

*119(h) Procedures which prescribe the scheduling and conduct of inspections to detect cracks and other indications of potential failures in CWR joints. In formulating the procedures under this paragraph, the track owner shall—*

**Guidance:** This paragraph requires each track owner to include in its CWR plan provisions for the scheduling and conducting of joint inspections. A person who is qualified under § 213.7(c) will perform the inspections required by this paragraph on foot at the joint.

*(1) Address the inspection of joints and the track structure at joints, including, at a minimum, periodic on-foot inspections.*

**Guidance:** This paragraph governs on-foot periodic inspections of CWR joints. Track owners are required to establish procedures for conducting these inspections. Upon identifying actual conditions of joint failures (i.e., broken or cracked joints bars) or potential conditions of joint failure, track owners must initiate the appropriate corrective action and keep the appropriate records. See §§ 213.119(h)(5) and 213.119(h)(7). In addition, when a track owner discovers CWR joints that are not in compliance with the requirements of the TSS, the track owner must take the appropriate remedial action required by Part 213. Inspectors should note that nothing in this paragraph interferes with the track owners' continuing obligation to conduct track inspections under § 213.233. In addition, on-foot periodic inspections can be performed concurrently with § 213.233.

Periodic inspections, as referenced herein, are on-foot inspections of CWR joints that track owners must conduct on a regular basis. Track owners are required to conduct on-foot periodic inspections at the minimum intervals specified in paragraph (h)(6). Track owners, of course, are free to conduct these inspections more frequently than required.

*(2) Identify joint bars with visible or otherwise detectable cracks and conduct remedial action pursuant to § 213.121;*

**Guidance:** This paragraph requires track owners to identify joint bars with visible or otherwise detectable cracks and conduct remedial action pursuant to § 213.121. Railroad inspectors must know to distinguish between joint bars that are already cracked and joint bars that have the potential of cracking in the future. When a track owner discovers a cracked joint bar, the owner must take any remedial action specified in § 213.121; however,

if the owner discovers a joint bar with actual or potential joint failure, the owner must take the corrective action specified by the CWR plan. Corrective action will be further addressed in paragraph (h)(5).

(3) *Specify the conditions of actual or potential joint failure for which personnel must inspect, including, at a minimum, the following items:*

(i) *Loose, bent, or missing joint bolts;*

(ii) *Rail end batter or mismatch that contributes to instability of the joint; and*

(iii) *Evidence of excessive longitudinal rail movement in or near the joint, including, but not limited to; wide rail gap, defective joint bolts, disturbed ballast, surface deviations, gap between tie plates and rail, or displaced rail anchors;*

**Guidance:** This paragraph identifies those items relating to joint inspections that track owners must address in their CWR plans. Inspectors should note that these items are the minimum that track owners should address. Of course, track owners are free to include additional items in their respective CWR plans. Railroad track inspectors are to identify and record action items listed during their inspection of joints because these items are related to the integrity of the joint, and thus, to the safety of trains that operate over these joints.

Inspectors should note that this list is not all-inclusive. There are other conditions that could indicate failure, and inspectors should urge track owners to consider all conditions, not just these listed examples.

(4) *Specify the procedures for the inspection of CWR joints that are imbedded in highway-rail crossings or in other structures that prevent a complete inspection of the joint, including procedures for the removal from the joint of loose material or other temporary material;*

**Guidance:** This paragraph requires track owners to include procedures in their CWR plans for the inspection of CWR joints that are imbedded in highway-rail grade crossings or in other structures that prevent a complete inspection of the joint (e.g., pans in fueling facilities, scales, passenger walkways at stations that cover the track, etc.). The plans must also include procedures for the removal of loose material or other temporary material from the joint.

With respect to the procedures for “imbedded” joints, inspectors should not expect railroads to disassemble or remove the track structure (e.g., remove pavement or crossing pads) to conduct an inspection of CWR joints. However, FRA expects that railroads will make every effort, to the extent practicable, to inspect the joints in these structures.

Inspectors need to be aware that CWR joints may sometimes be temporarily buried during maintenance (e.g., where ballast is distributed in the middle of the track and along the track) and therefore unavailable for inspection. FRA expects that railroads will take necessary measures to conduct inspections of these CWR joints and expects that railroads will schedule their maintenance to allow for a complete inspection of these joints. Where CWR joints are buried (e.g., by ballast), inspectors should understand that railroad maintenance personnel will wait for the completion of the track surfacing and dressing of the ballast before conducting their joint bar inspections. However, railroad employees may use hand tools or mechanical means to remove ballast from the sides of track joints, so that they can conduct an inspection of those track joints.

Finally, FRA notes that components of the track (such as crossties, fasteners, tie plates, etc.) are also not fully visible in highway-rail grade crossings and similar structures. Inspectors should note that FRA has never specifically exempted these items from the inspections required under Part 213. Inspectors should continue to expect that the railroads will inspect these areas to the maximum extent possible.

- (5) *Specify the appropriate corrective actions to be taken when personnel find conditions of actual or potential joint failure, including on-foot follow-up inspections to monitor conditions of potential joint failure in any period prior to completion of repairs;*

**Guidance:** This paragraph requires track owners to specify in their plans the appropriate corrective actions that must be taken when track inspectors find conditions of actual or potential joint failure. Inspectors should note the difference between the terms “remedial actions” and “corrective action” and apply accordingly. Remedial actions are those actions which track owners are required to take as a result of requirements of Part 213 to address a noncompliant condition. For example, if a track owner discovers a cracked joint bar, the owner must replace it. See § 213.121 or the parallel requirement in the railroad’s CWR plan. Corrective actions, on the other hand, are those actions that track owners specify in their CWR plans to address conditions of potential joint failure, including, as applicable, repair, restrictions on operations, and/or additional on-foot inspection. To ensure clarity, FRA has defined these terms in § 213.119(j).

On-foot follow-up inspections, as referenced herein, are joint-specific and conducted in response to conditions that a track owner discovers during periodic inspections. Track owners will identify in their CWR plans the conditions that trigger follow-up inspections. For example, where a track owner identifies “replace bolt or inspect weekly” as a corrective action for a bent bolt, if a track inspector discovers a bent bolt during a periodic inspection and does not immediately replace it, then the track inspector will have to conduct follow-up inspections at that joint at the specified frequency (in this case, weekly).

- (6) *Specify the timing of periodic inspections, which shall be based on the configuration and condition of the joint:*

**Guidance:** This paragraph requires railroad owners to specify the timing of on-foot periodic inspections. The minimum number of required joint inspections is addressed in the table in paragraph (h)(6)(i). The timing periods in this paragraph represent the minimum of what is expected. Railroad owners are encouraged to implement additional inspection periods as they determine necessary.

In paragraphs (h)(6)(ii) through (iv), inspectors should be aware that FRA is allowing exceptions to the minimum inspection frequencies for unscheduled detours, certain passenger trains, and items that are already inspected on a monthly basis pursuant to § 213.235. Each of these exceptions will be discussed in more detail below.

- (i) *Except as provided in paragraphs (h)(6)(ii) through (h)(6)(iv) of this section, track owners must specify that all CWR joints are inspected, at a minimum, in accordance with the intervals identified in the following table:*

***Minimum Number of Inspections per Calendar Year<sup>1</sup>***

	<i>Freight trains operating over track with an annual tonnage of:</i>			<i>Passenger trains operating over track with an annual tonnage of:</i>	
	<i>Less than 40 mgt</i>	<i>40 to 60 mgt</i>	<i>Greater than 60 mgt</i>	<i>Less than 20 mgt</i>	<i>Greater than or equal to 20 mgt</i>
<i>Class 5 &amp; above</i>	2	3 <sup>2</sup>	4 <sup>2</sup>	3 <sup>2</sup>	3 <sup>2</sup>
<i>Class 4</i>	2	3 <sup>2</sup>	4 <sup>2</sup>	2	3 <sup>2</sup>
<i>Class 3</i>	1	2	2	2	2
<i>Class 2</i>	0	0	0	1	1
<i>Class 1</i>	0	0	0	0	0
<i>Excepted track</i>	0	0	0	n/a	n/a

*4 = Four times per year, with one inspection in each of the following periods: January to March, April to June, July to September, and October to December; and with consecutive inspections separated by at least 60 calendar days.*

*3 = Three times per calendar year, with one inspection in each of the following periods: January to April, May to August, and September to December; and with consecutive inspections separated by at least 90 calendar days.*

*2 = Twice per calendar year, with one inspection in each of the following periods: January to June and July to December; and with consecutive inspections separated by at least 120 calendar days.*

*1 = Once per calendar year, with consecutive inspections separated by at least 180 calendar days.*

<sup>1</sup>Where a track owner operates both freight and passenger trains over a given segment of track, and there are two different possible inspection interval requirements, the more frequent inspection interval applies.

<sup>2</sup> When extreme weather conditions prevent a track owner from conducting an inspection of a particular territory within the required interval, the track owner may extend the interval by up to 30 calendar days from the last day that the extreme weather condition prevented the required inspection

**Guidance:** The first footnote provides that where a track owner operates both freight and passenger trains over a given segment of track, and there are two different possible inspection interval requirements, the more frequent inspection interval applies. This footnote was developed to address concerns over track shared by freight and passenger trains. It was anticipated that there could be a potential conflict with the inspection frequency required for the track if the track owner were to follow the chart for both types of trains. By requiring the more frequent inspections in situations of conflict, this footnote ensures greater safety and protection to track used for mixed purposes.

The second footnote was added in response to concerns regarding sensitivity of extreme regional weather conditions. Concern was raised with regard to the difficulty of inspecting CWR joints in northern regions when there is a large amount of snow. FRA notes that there could be times when it would be extremely difficult for a track owner to clear snow and ice

from the joint in order for it to be seen for inspection. This footnote allows some flexibility for track owners in such a situation.

*(ii) Consistent with any limitations applied by the track owner, a passenger train conducting an unscheduled detour operation may proceed over track not normally used for passenger operations at a speed not to exceed the maximum authorized speed otherwise allowed, even though CWR joints have not been inspected in accordance with the frequency identified in paragraph (h)(6)(i) of this section, provided that:*

*(A) All CWR joints have been inspected consistent with requirements for freight service; and*

*(B) The unscheduled detour operation lasts no more than 14 consecutive calendar days. In order to continue operations beyond the 14-day period, the track owner must inspect the CWR joints in accordance with the requirements of paragraph (h)(6)(i) of this section.*

**Guidance:** This paragraph allows track owners, for a limited period of time, to operate passenger trains without lowering the track speed and without adhering to the required inspection frequencies for passenger trains pursuant to the table in § 213.119(h)(6)(i). This provision accommodates for unplanned outages, derailments, accidents, and other emergency situations. Track owners are still required to adhere to the applicable freight inspection frequencies. This provision is intended to provide relief to railroads that operate passenger trains and that have a last-minute emergency situation. However, if a track owner operates passenger trains at the normal track speed for more than 14 days, the track must be inspected at the appropriate passenger train levels, as detailed in the chart at § 213.119(h)(6)(i).

*(iii) Tourist, scenic, historic, or excursion operations, if limited to the maximum authorized speed for passenger trains over the next lower class of track, need not be considered in determining the frequency of inspections under paragraph (h)(6)(i) of this section.*

**Guidance:** As defined in § 213.119(l), tourist, scenic, historic, or excursion operations are railroad operations that carry passengers with the conveyance of the passengers to a particular destination not being the principal purpose. These operations run less frequently than intercity or commuter passenger trains, and occur most often on shortline railroads. If a track owner has an operation of this type on the track and does not want to take that operation into account in determining inspection frequency, the owner must drop the track speed one class with regard to that operation. This way, the track owner will be still be in compliance with the inspection frequency mandated by the table in paragraph (h)(6)(i), regardless of the class of freight the owner runs on the track. As the first footnote to the table in paragraph (h)(6)(i) states, where there are two different possible inspection interval requirements, the more frequent inspection interval applies.

The above is a consideration for situations where tourist trains operate on the general system of transportation. For tourist trains on track other than the general system of transportation, such operations are normally not subject to the TSS. See Part 209, Appendix A.

*(iv) All CWR joints that are located in switches, turnouts, track crossings, lift rail assemblies or other transition devices on moveable bridges must be inspected on foot at least monthly, consistent with the requirements in § 213.235; and all records of those inspections must be kept in accordance with the requirements in § 213.241. A track owner may include in its §*

*213.235 inspections, in lieu of the joint inspections required by paragraph (h)(6)(i) of this section, CWR joints that are located in track structure that is adjacent to switches and turnouts, provided that the track owner precisely defines the parameters of that arrangement in the CWR plans.*

**Guidance:** This paragraph exempts the following items from the periodic inspection frequency intervals: switches, turnouts, track crossings, lift rail assemblies, or other transition devices on moveable bridges. Track owners already inspect these items on a monthly basis pursuant to § 213.235. Rather than apply the additional periodic inspection requirements (i.e., apply the intervals in the table in § 213.119(h)(6)(i) to switches and turnouts, etc.), FRA believes it is more appropriate to have track owners conduct their inspections of joints at these locations during their monthly § 213.235 inspections.

FRA has historically understood and operated under the assumption that a turnout extends from the point of the switch to the heel of the frog. Inspectors should continue to operate under that assumption, and accordingly, all joints in turnouts, switches, etc. must be inspected monthly, pursuant to § 213.235, and records of these inspections must be kept in accordance with § 213.241. The regulation does not require that the data elements listed in § 213.119(h)(7)(i) appear on the § 213.235 inspection record.

All joints that extend beyond the point of a switch or beyond the heel of the frog must be inspected at the frequency intervals identified in § 213.119(h)(6)(i). However, track owners are free to include, in their monthly § 213.235 inspection, these joints that are located in track structure that is adjacent to turnouts and switches. If track owners choose to do this, they must clearly define the parameters of that arrangement in their CWR plan. In other words, the track owner should clearly identify the physical limits of the adjacent track structure (e.g., insulated joints up until the signal), and they must clearly identify the inspection interval for joints in that adjacent track (e.g., “inspect all insulated joints to the signal during the monthly § 213.235 inspection”).

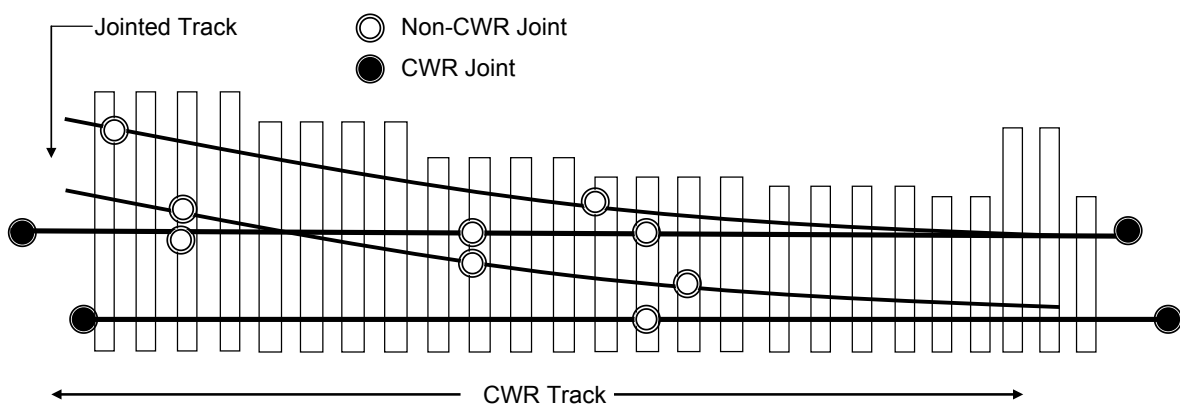

In addition, as long as track owners clearly define the parameters in the CWR plans, the track owner does not need to keep two sets of records (e.g., a record from the § 213.235 inspection and a record from the § 213.119(h)(6)(i) inspection) for inspections of these “adjacent” joints. For example, if the track owner’s CWR plan indicates that joints in crossovers between turnouts must be inspected during the monthly § 213.235 inspection, and a railroad track inspector inspects the joints in the crossover during the monthly §



213.235 inspection, then it is sufficient for the track owner to create and maintain only the § 213.235 record.

FRA believes this option is useful because it avoids the confusion and duplication that might otherwise result. In addition, FRA notes that it would be burdensome for track inspectors to inspect those “adjacent” joints monthly and make a note of the inspection in the monthly § 213.235 record, and also be required to make an additional § 213.119(h)(6)(i) record every few months.

*(7) Specify the recordkeeping requirements related to joint bars in CWR, including the following:*

*(i) The track owner shall keep a record of each periodic and follow-up inspection required to be performed by the track owner’s CWR plan, except for those inspections conducted pursuant to § 213.235 for which track owners must maintain records pursuant to § 213.241. The record shall be prepared on the day the inspection is made and signed by the person making the inspection. The record shall include, at a minimum, the following items: the boundaries of the territory inspected; the nature and location of any deviations at the joint from the requirements of this part or of the track owner’s CWR plan, with the location identified with sufficient precision that personnel could return to the joint and identify it without ambiguity; the date of the inspection; the remedial action, corrective action, or both, that has been taken or will be taken; and the name or identification number of the person who made the inspection.*

**Guidance:** This paragraph addresses the inspection reports that have to be created after periodic inspections required by paragraph (h)(6)(i), and follow-up inspections as required by the track owner’s CWR plan. The inspection reports of the periodic inspections shall be prepared on the day the inspection is made and are to contain the required information. The periodic inspection record can be combined with other records required pursuant to § 213.241.

*(ii) [Reserved]*

**Guidance:** Section 213.119(h)(7)(ii) is removed. This eliminates the requirement for the railroad to send a copy of the joint bar fracture report to FRA. This also includes removal of paragraphs (A), (B) and (C).

*(8) In lieu of the requirements for the inspection of rail joints contained in paragraphs (h)(1) through (h)(7) of this section, a track owner may seek approval from FRA to use alternate procedures.*

*(i) The track owner shall submit the proposed alternate procedures and a supporting statement of justification to the Associate Administrator.*

*(ii) If the Associate Administrator finds that the proposed alternate procedures provide an equivalent or higher level of safety than the requirements in paragraphs (h)(1) through (h)(7) of this section, the Associate Administrator will approve the alternate procedures by notifying the track owner in writing. The Associate Administrator will specify in the written notification the date on which the procedures will become effective, and after that date, the track owner shall comply with the procedures. If the Associate Administrator determines that the alternate procedures do not provide an equivalent level of safety, the Associate Administrator will disapprove the alternate procedures in writing, and the track owner shall continue to comply with the requirements in paragraphs (h)(1) through (h)(7) of this section.*

*(iii) While a determination is pending with the Associate Administrator on a request submitted pursuant to paragraph (h)(8) of this section, the track owner shall continue to comply with the requirements contained in paragraphs (h)(1) through(h)(7) of this section.*

**Guidance:** This paragraph permits a track owner to devise an alternate program for the inspection of joints in CWR. A track owner seeking to deviate from the minimum inspection frequencies specified in § 213.119(h)(6) should submit the alternate procedures and a supporting statement of justification to FRA’s Associate Administrator for Railroad Safety/Chief Safety Officer. In the supporting statement, the track owner must include data and analysis that establishes (to the satisfaction of the Associate Administrator for Railroad Safety/Chief Safety Officer) that the alternate procedures provide at least an equivalent level of safety across the railroad.

If the Associate Administrator for Railroad Safety/Chief Safety Officer approves the alternate procedures, the Associate Administrator for Railroad Safety/Chief Safety Officer will notify the track owner of such approval in writing. In that written notification, the Associate Administrator for Railroad Safety/Chief Safety Officer will specify the date that the alternate procedures will become effective. After that date, the track owner shall comply with the approved procedures. If the Associate Administrator for Railroad Safety/Chief Safety Officer determines that the alternate procedures do not provide an equivalent level of safety, the Associate Administrator for Railroad Safety/Chief Safety Officer will disapprove the alternate procedures in writing. While a determination is pending with the Associate Administrator for Railroad Safety/Chief Safety Officer, the track owner shall continue to comply with the requirements contained in § 213.119(h)(6).

Technology (including frequent automated track geometry surveys) and sound CWR management, including prompt removal of “temporary” joints, may provide the additional information required to verify the ongoing integrity of joints in CWR. The alternative procedures provision of this final rule will allow track owners to take advantage of these new approaches as they become available.

*119(i) The track owner shall have in effect a comprehensive training program for the application of these written CWR procedures, with provisions for annual re-training, for those individuals designated under § 213.7(c) as qualified to supervise the installation, adjustment, and maintenance of CWR track and to perform inspections of CWR track. The track owner shall make the training program available for review by FRA upon request.*

**Guidance:** All railroad employees designated under § 213.7(c) as qualified to supervise the installation, adjustment, and maintenance of CWR track and to perform inspections of CWR track must be trained on the track owner’s CWR plan. The track owner shall maintain a written record of this training in accordance with § 213.7(d). Inspectors should refer any requests for training programs to their regional office. Railroad representatives agree to voluntarily make an initial submission of their CWR training programs to FRA. Track inspectors should not request the training program of a specific track owner unless under the specific direction of FRA management. Rather, FRA headquarters staff will undertake the responsibility of obtaining and disseminating this information, as needed, to both FRA inspectors and State inspectors participating in rail safety enforcement activities under Title 49 Code of Federal Regulations (CFR) Part 212. However, inspectors can request a copy of the track owner’s qualification list during regular business hours.

*119(j) The track owner shall prescribe and comply with recordkeeping requirements necessary to provide an adequate history of track constructed with CWR. At a minimum, these records must include:*

- (1) Rail temperature, location, and date of CWR installations. Each record shall be retained for at least one year;*
- (2) A record of any CWR installation or maintenance work that does not conform to the written procedures. Such record shall include the location of the rail and be maintained until the CWR is brought into conformance with such procedures; and*
- (3) Information on inspection of rail joints as specified in paragraph (h)(7) of this section.*

**Guidance:** Paragraph (j) contains the recordkeeping requirements for railroads that have track constructed of CWR. At a minimum, a track owner must keep records of the items listed in paragraphs (j)(1) through (j)(3). Paragraph (j)(1) requires each railroad to keep a record of the rail temperature, location, and date of the CWR installations. Paragraph (j)(2) requires a track owner to keep a record of any CWR installation or maintenance work that does not conform with the written procedures. Also, (f)(2) requires the railroad to determine the difference between the average rail temperature and the average rail neutral temperature. This necessitates the recording of rail neutral temperatures at rail repair locations that do not conform to the procedures. Paragraph (j)(3) requires a track owner to keep records of information on inspection of rail joints as specified in paragraph (h)(7).

*119(k) The track owner shall make readily available, at every job site where personnel are assigned to install, inspect or maintain CWR, a copy of the track owner's CWR procedures and all revisions, appendices, updates, and referenced materials related thereto prior to their effective date. Such CWR procedures shall be issued and maintained in one CWR standards and procedures manual.*

**Guidance:** Since the implementation of the CWR regulations, FRA has noted that a number of rail carriers maintain two different sets of CWR procedures. Additionally, some railroads have been maintaining the set of CWR procedures submitted to FRA as required by this section (§ 213.119), as well as a separate set of CWR procedures that is used by personnel in the field. While it may be acceptable for a railroad to instruct its personnel to maintain more restrictive CWR procedures in the field than what is on file with FRA, it is important to note that railroads must train their personnel on the plan formally submitted and filed with FRA. As FRA enforces the track owner's CWR plan on file with its Office of Railroad Safety, it is critical to have these procedures at every job site where personnel are assigned to install, inspect, or maintain CWR. Specifically, this will ensure that personnel in the field understand which set of procedures FRA will hold them responsible for compliance with the TSS.

*119(l) As used in this section—*

***Adjusting/de-stressing*** means the procedure by which a rail's temperature is re-adjusted to the desired value. It typically consists of cutting the rail and removing rail anchoring devices, which provides for the necessary expansion and contraction, and then re-assembling the track.

***Annual re-training*** means training every calendar year.

***Buckling incident*** means the formation of a lateral misalignment sufficient in magnitude to constitute a deviation from the Class 1 requirements specified in § 213.55. These normally

occur when rail temperatures are relatively high and are caused by high longitudinal compressive forces.

**Buckling-prone condition** means a track condition that can result in the track being laterally displaced due to high compressive forces caused by critical rail temperature combined with insufficient track strength and/or train dynamics.

**Continuous welded rail (CWR)** means rail that has been welded together into lengths exceeding 400 feet. Rail installed as CWR remains CWR, regardless of whether a joint or plug is installed into the rail at a later time.

**Corrective Actions** mean those actions which track owners specify in their CWR plans to address conditions of actual or potential joint failure, including, as applicable, repair, restrictions on operations, and additional on-foot inspections.<sup>1</sup>

**CWR joint** means any joint directly connected to CWR.

**Desired rail installation temperature range** means the rail temperature range, within a specific geographical area, at which forces in CWR should not cause a buckling incident in extreme heat, or a pull-apart during extreme cold weather.

**Disturbed Track** means the disturbance of the roadbed or ballast section, as a result of track maintenance or any other event, which reduces the lateral or longitudinal resistance of the track, or both.

**Mechanical stabilization** means a type of procedure used to restore track resistance to disturbed track following certain maintenance operations. This procedure may incorporate dynamic track stabilizers or ballast consolidators, which are units of work equipment that are used as a substitute for the stabilization action provided by the passage of tonnage trains.

**Pull apart or stripped joint** means a condition when no bolts are mounted through a joint on the rail end, rendering the joint bar ineffective due to excessive expansive or contractive forces.

**Pull-apart prone condition** means a condition when the actual rail temperature is below the rail neutral temperature at or near a joint where longitudinal tensile forces may affect the fastenings at the joint.

**Rail anchors** means those devices which are attached to the rail and bear against the side of the crosstie to control longitudinal rail movement. Certain types of rail fasteners also act as rail anchors and control longitudinal rail movement by exerting a downward clamping force on the upper surface of the rail base.

**Rail neutral temperature** is the temperature at which the rail is neither in compression nor tension.

**Rail temperature** means the temperature of the rail, measured with a rail thermometer.

**Remedial Actions** mean those actions which track owners are required to take as a result of requirements of this part to address a non-compliant condition.

**Tight/kinky rail** means CWR which exhibits minute alignment irregularities which indicate that the rail is in a considerable amount of compression.

---

<sup>1</sup> Note, this term is used in § 213.119(h)(5).

**Tourist, scenic, historic, or excursion operations** mean railroad operations that carry passengers with the conveyance of the passengers to a particular destination not being the principal purpose.

**Track lateral resistance** means the resistance provided by the rail/crosstie structure against lateral displacement.

**Track longitudinal resistance** means the resistance provided by the rail anchors/rail fasteners and the ballast section to the rail/crosstie structure against longitudinal displacement.

**Train-induced forces** means the vertical, longitudinal, and lateral dynamic forces which are generated during train movement and which can contribute to the buckling potential of the rail

**Unscheduled detour operation** means a short-term, unscheduled operation where a track owner has no more than 14 calendar days' notice that the operation is going to occur.

### § 213.121 Rail joints

121(a) Each rail joint, insulated joint, and compromise joint shall be of a structurally sound design and dimensions for the rail on which it is applied.

**Guidance:** For proper rail load transfer to occur, rail joints must contact the head and base of the rails when the bolts are tight. Many rail joint designs have been used with varying degrees of success, and the TSS does not attempt to single out any particular design as the only acceptable joint. This could inhibit innovation in modern track design.

The TSS requires structural soundness and bolt condition based on maximum authorized train speed. Inspectors must be attentive to locations where standard joint bars are used to join dissimilar rail sections where it would be proper to have compromise bars.

The TSS recognize these important aspects of rail joints and begin this section with a requirement that rail joints have a structurally sound design and dimension for the rail on which they are applied.

Rail joints are considered to be a necessary discontinuity and require special attention by railroad maintenance personnel, railroad inspectors, and FRA inspectors. As far as possible, a rail joint should provide the same relative strength, stiffness, flexibility, and uniformity as the rail itself. The following figure illustrates the proper application of compromise joint bars.

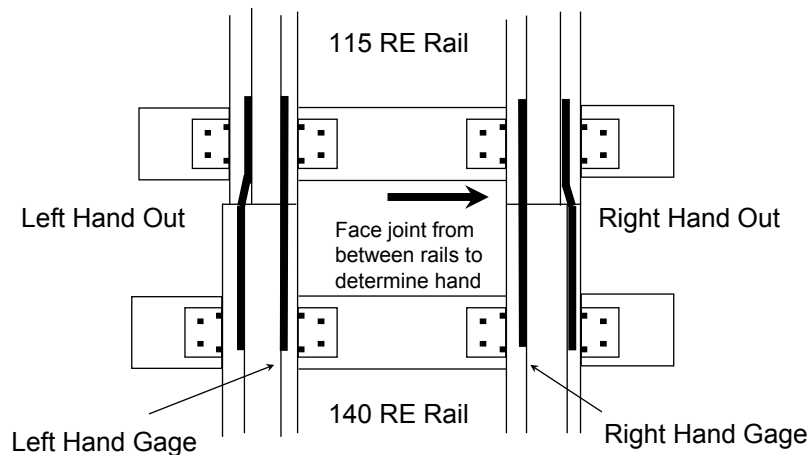

As shown in the following figure, one of the design elements of joint bars to consider is if it's a head-contact or head-free design:

- The head-contact bar supports the rail ends with a box-type construction, carrying the load between the underside of the head and the base of the rail.
- The head-free joint bar does not contact the underside of the rail heads, but instead contacts the rail in the fillet area. The load distribution is referred to as a triangular load distribution.

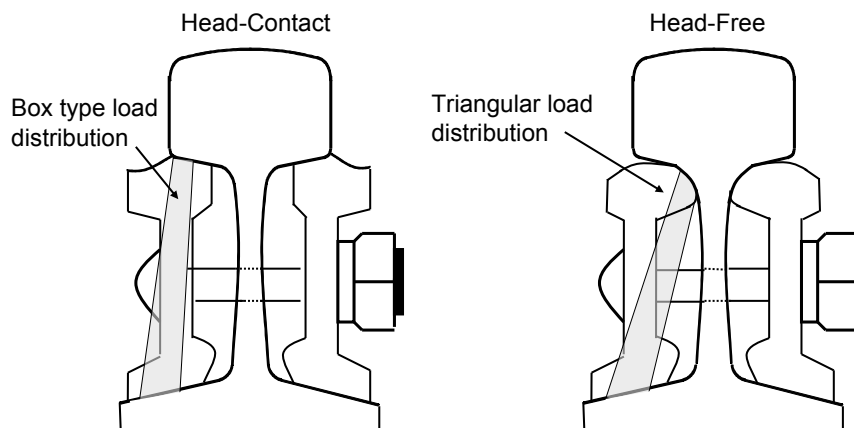

The use of a standard (noncompromise) joint bar of head-contact design on a rail section other than for designed may constitute a deviation. The differences between the head-contact joint bar and the head-free joint bar are significant.

It is evident the joint bar and the rails do not bend or flex exactly with each other along their length. Tests and measurements show that for positive bending, there exists a downward bearing pressure of the under side of the head of the rail on the top surface of the joint bars for some distance along the bar away from the rail ends, (approximately 2 inches). There is also an upward bearing pressure of the upper surface of the base of the rails at parts of the length of the bar further away from the rail end, (bearing distance approximately 3 inches). The converse is true for negative bending.

The head-free joint bar accepts bearing and shear forces from vertical loads in the rail's upper fillet. A head-contact bar is not designed to fit into the fillet. Specifically, the head-contact joint bar accepts bearing from vertical loads on the flat underside of the rail's head: generally on a 1 to 4 slope. It is not designed to seat into the rail's upper fillet. Although the vertical fishing dimension for the 112 and 115 RE rail sections is identical ( $3\frac{3}{16}$  inches), the head fillet radius is different:

- For the 115-pound section, radius equals three-fourths of an inch
- For the 112-pound section, radius equals three-eighths of an inch

As shown in the following figure, the 115 head-free bar fits the 112 rail fillet practically at a point, most probably inducing joint bar stresses in excess of design which is a deviation from § 213.121(a). The 112 head-contact bar does properly not fit into the 115 rail fillet as it bears in very small areas beneath the head of the rail, possibly inducing joint bar stresses in excess of design and exerting a wedge action between the rail head and rail web, promoting head and web separation. In addition, the joint bar may experience a twist, or torsional force from the tightening of the track bolts when used as a compromise between 115 and 112 rail. The torsional stress from twist will be the greatest at the head and toe of the bar at the rail ends.

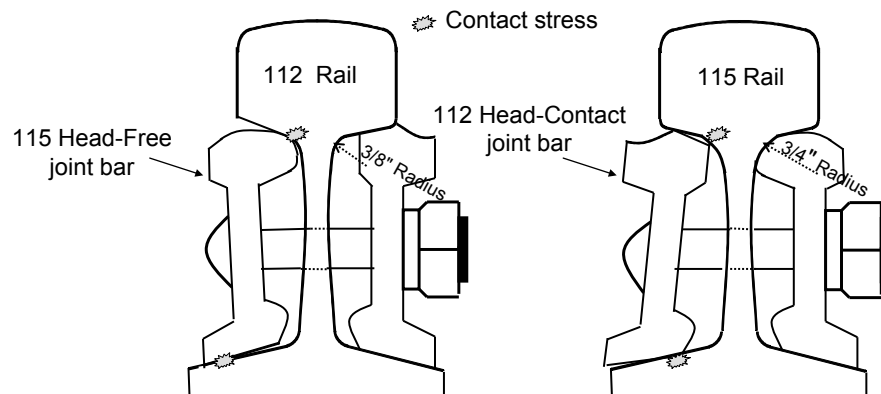

There are exceptions to the use of a joint bar of head-contact design on a rail section other than for designed. For example, a 131-pound or 132-pound head-contact joint bar may be used in lieu of a 131/132 or 131/136 compromise joint bar if rail drilling and joint bar punching is the same. The width of the rail head in these configurations is sufficient to allow full contact in the upper fishing wear surface. In summary:

- 112-pound RE joint bars should not be used as compromise joint bars between 112 RE and 115 RE rail.
- 115-pound RE joint bars should not be used as compromise joint bars between 112 RE and 115 RE rail.
- 131 RE head-contact bars or 132 RE head-contact bars may be used as compromise joint bars between 131 RE and 132 RE rail or 136 RE rail where rail drilling and joint

bar punching are the same. (Note: FRA Standards do not prohibit the track owner from field drilling bolt holes to fit).

While the above addresses compromise joint bars, it is stressed that 112 RE bars are not to be used on 115 RE and 119 RE rail and vice versa. Joint bars with 131 RE head-free and 132 RE head-free design, or 131 RE head-free and 136 RE head-free joint bars, are not interchangeable and are not to be intermixed.

For a compendium of rail section dimensions in order to compare other rail sections for compatibility between joint bars on various rail sections refer to Appendix C of this manual.

*121(b) If a joint bar on Classes 3 through 5 track is cracked, broken, or because of wear allows excessive vertical movement of either rail when all bolts are tight, it shall be replaced.*

**Guidance:** Joint bars are designed to fit into the space between the bottom of the rail head and rail base (fishing). With the bolts tight, the joint bars are wedged into the fishing space to provide lateral and vertical beam strength thereby supporting the abutting rail ends. When held up against the rail with bolts, joint bars contact the rail at two points; bottom of the rail head (or fillet) and top of the rail base. These contact points, known as the “fishing surfaces,” can experience metal loss due to abrasion and mechanical wear that occurs during the cyclical train dynamic loading. After long-term service, the fishing surfaces of the rails and bars can wear to the point that joint bars are no longer wedged into the rail, even with tight bolts. In such cases, the joint assembly will no longer optimally support the abutting rail ends.

Joints with minimally worn fishing surfaces can provide for the safe passage of wheels in Classes 1 through 5. As a guide, excessive vertical movement would exist when there is significant fishing surface wear and wheel loads cause the abutting rail ends to exhibit tread mismatch approaching the thresholds under § 213.115. If excessive vertical movement occurs, or there are any cracks, corrective action would be to replace the bars or take other proper corrective action.

Proper corrective action for a joint bar cracked or broken, other than center break, in Classes 3 through 5 track, would be replacement or a reduction to Class 2. If both joint bars are cracked or broken between the 1st and 2nd bolt hole (including through the 2nd bolt hole), it should be considered Class 1. This is because there is only one bolt in a rail end that is within the remaining section of the joint bar that is providing support.

*121(c) If a joint bar is cracked or broken between the middle two bolt holes it shall be replaced.*

**Guidance:** For a center cracked or broken bar, the appropriate corrective action would be replacement or reduction to Class 1 speeds under the provisions of § 213.9(b).

*121(d) In the case of conventional jointed track, each rail shall be bolted with at least two bolts at each joint in Classes 2 through 5 track, and with at least one bolt in Class 1 track.*

**Guidance:** Track owners must have the number of required bolts in each rail in a joint. This paragraph does not prescribe a tightness (torque) standard for each bolt. A bolt that no longer can support the joint bar against the rail will continue to provide resistance to pull



aparts when the rail is in tension. The ability of the bolts to hold bars against the rail to support the abutting rail ends is covered under § 213.121(f).

A bolt does not fulfill the requirements of this paragraph if it is in imminent danger of complete failure (it no longer is holding the bar to the rail and no longer resists pull apart forces). For example, the nut is missing (it will likely fall out under subsequent train movements) or the bolt shaft is fractured.

*121(e) In the case of continuous welded rail track, each rail shall be bolted with at least two bolts at each joint.*

**Guidance:** Rail installed as CWR remains as CWR, regardless of whether a joint or plug is installed at a later time. If there is only one bolt in a rail end at a joint, in a CWR string, that one bolt will be subject to all the tensile axial forces and will easily shear (break) resulting in a pull-apart.

*121(f) Each joint bar shall be held in position by track bolts tightened to allow the joint bar to firmly support the abutting rail ends and to allow longitudinal movement of the rail in the joint to accommodate expansion and contraction due to temperature variations. When no-slip, joint-to-rail contact exists by design, the requirements of this paragraph do not apply. Those locations when over 400-feet in length, are considered to be continuous welded rail track and shall meet all the requirements for continuous welded rail track prescribed in this part.*

**Guidance:** If the joint bars are loose, the joint is not in compliance with § 213.121(f). In addition, a joint assembly is not in compliance when inadequately tightened bolts prevent it from supporting the abutting rail ends under the expected traffic loads.

Joint bolts can deteriorate sufficiently as to create a condition where the bars may become completely detached from the rail or cause a total lack of support, which can contribute to a broken rail. Such a condition can create a mismatch which exceeds the limits specified in § 213.115 (Rail end mismatch). In such a case, the defect would be rail end mismatch (class specific) and inspectors should also include a notation about the loose joint bars.

This paragraph also recognizes the design characteristic that enables the rail ends in a joint to move longitudinally to handle temperature changes (expansion/contraction) or rail creep (traffic flow). This type of joint bar assembly is standard for jointed rail because that type of track construction has lower axial forces than CWR. In CWR, it is desirable to contain the rail expansion and contraction in the remaining joints (i.e., insulated joints) in order to eliminate the pull-apart action that occurs in regular joints. In CWR, the track structure, by design, dissipates the axial forces. Accordingly, this paragraph allows joint designs that stop the axial rail movement within the assembly.

Except for the axial movement component of this paragraph, joint bars such as glued insulated joints are subject to all of the remaining requirements of this paragraph and all other paragraphs of § 213.121. These types of assemblies are considered to be joints, even in CWR (see § 213.119). However, for the definition as to what constitutes CWR, a glued joint is not a longitudinal discontinuity in a rail string. Glued joints are also considered joints under § 213.109 with respect to the required positioning of nondefective ties at joints.

*121(g) No rail shall have a bolt hole which is torch cut or burned in Classes 2 through 5 track.*

**Guidance:** This paragraph prohibits the use of a rail containing a bolt hole that has been torch cut or burned in Classes 2 through 5 track.

*121(h) No joint bar shall be reconfigured by torch cutting in Classes 3 through 5 track.*

**Guidance:** This paragraph prohibits the reconfiguration of joint bars by torch cutting in Classes 3 through 5 track. By omission of the reference to Classes 1 and 2 track, this practice of reconfiguration is allowed in those classes. However, the joint bars that are reconfigured by torch cutting must meet certain criteria for structural soundness of design and dimension, which is required under (a) of this section.

### **§ 213.122 Torch cut rail**

*122(a) Except as a temporary repair in emergency situations no rail having a torch cut end shall be used in Classes 3 through 5 track. When a rail end is torch cut in emergency situations, train speed over that rail end shall not exceed the maximum allowable for Class 2 track. For existing torch cut rail ends in Classes 3 through 5 track the following shall apply –*

- (1) Within one year of September 21, 1998, all torch cut rail ends in Class 5 track shall be removed;*
- (2) Within two years of September 21, 1998, all torch cut rail ends in Class 4 track shall be removed; and*
- (3) Within one year of September 21, 1998, all torch cut rail ends in Class 3 track over which regularly scheduled passenger trains operate, shall be inventoried by the track owner.*

**Guidance:** The regulation prohibits the torch cutting of rail ends in Classes 3 through 5 track except as a temporary repair in emergency situations. In such emergency situations, train speed shall not exceed the maximum allowable for Class 2 track.

Existing torch cuts must be removed from track in the following time frames:

- Class 5 track – by September 21, 1999.
- Class 4 track – by September 21, 2000.
- Class 3 track with passenger trains – by September 21, 1999, all torch cuts shall be inventoried by the track owner.

*122(b) Following the expiration of the time limits specified in (a)(1), (2), and (3) of this section, any torch cut rail end not removed from Classes 4 and 5 track, or any torch cut rail end not inventoried in Class 3 track over which regularly scheduled passenger trains operate, shall be removed within 30 days of discovery. Train speed over that rail end shall not exceed the maximum allowable for Class 2 track until removed.*

**Guidance:** Those torch cuts inventoried will be “grandfathered in” and any torch cuts found after the expiration of one year that are not inventoried must be slow ordered to Class 2 speed and removed within 30 days of discovery. If a railroad chooses to upgrade a segment of track to Class 3, and passenger trains are operated, all torch cuts must be removed before speeds can exceed the maximum for Class 2 track. If a railroad chooses to upgrade a segment of track from any lower class to Class 4 or 5, it must remove all torch cuts.

### § 213.123 Tie plates

*123(a) In Classes 3 through 5 track, where timber crossties are in use, there must be tie plates under the running rails on at least 8 of any 10 consecutive ties.*

*123(b) In Classes 3 through 5 track no metal object which causes a concentrated load by solely supporting a rail shall be allowed between the base of the rail and the bearing surface of the tie plate. This paragraph (b) is applicable September 21, 1999.*

**Guidance:** Inspectors should consider this section jointly with the requirements for crossties and rail fastenings and report tie plate conditions as defects where safety is impaired by the absence of tie plates.

In Classes 3 through 5 track no metal object that causes a concentrated load by solely supporting a rail shall be allowed between the base of rail and the bearing surface of the tie plate. The specific reference to “metal object” is intended to include only those items of track material that pose the greatest potential for broken base rails such as track spikes, rail anchors, and shoulders of tie plates. The phrase “causes a concentrated load by solely supporting a rail” further clarifies the intent of the regulation to apply only in those instances where there is clear physical evidence that the metal object is placing substantial load on the rail base, as indicated by a lack of loading on adjacent ties.

### § 213.127 Rail fastening systems

*(a) Track shall be fastened by a system of components that effectively maintains gage within the limits prescribed in § 213.53(b). Each component of each such system shall be evaluated to determine whether gage is effectively being maintained.*

**Guidance:** “Rail fastening systems” include modern-day elastic fastening systems, which can consist of abrasion pads, insulator clips, shoulder inserts cast into concrete ties, as well as the fastener itself, of which many different designs are in use today. The fastening system can also be of the traditional cut spike variety, with or without tie plates. The failure of certain critical components within a particular system could adversely affect the ability of the individual fastener to provide adequate gage restraint. The wording of this regulation provides for an evaluation of all components within the system, if necessary, when degradation of the fastening system has resulted in problems maintaining gage within the limits prescribed in § 213.53(b).

When an inspector identifies a gage geometry condition where the fastener system has degraded and the location in question meets the factors described below, the inspector must examine each component of the fastener system (e.g., clip, insulating pad, bolts, spiking pattern, etc.). The inspector should describe the nature of the failed components on the F6180.96 form. If a fastener condition causes the gage to exceed the limits of § 213.53, the inspector shall report the condition as a gage defect and describe the nature of the fastener condition on the same defect line of the report.

This section requires the inspector to exercise judgment in evaluating the condition of fasteners. The following factors should be considered in the evaluation:

- Gage exceeding the limits of § 213.53 (in such cases gage and track class will govern).

- Gage close to the limits of § 213.53 with evidence of recent widening.
- Evidence of recent rapid deterioration of gage with probable continued deterioration.
- Evidence of recent significant damage to rail fasteners to the extent that gage widening is probable.
- Evidence of recent maintenance work improperly performed resulting in lack of sufficient fasteners to prevent gage widening under expected traffic.
- Traffic conditions, including speed, tonnage, and type of equipment.
- Conditions of curvature and grades.

FRA inspectors may use a PTLF described in § 213.110 for the purposes of measuring the effectiveness of fasteners. Refer to Appendix D - PTLF instructions for non-GRMS territory under § 213.53.

A unique attribute of concrete crossties is the abrasion that can occur between the base of the rail and the rail-seat on the crosstie, a component of the rail fastening system. A variety of tie pad designs and materials are placed between the rail and the ties to mitigate abrasion. However, unequal or “wedged” abrasion of the rail seat can be problematic for a high-speed or high-tonnage operating environment that may cause rail fasteners to become loose under load or in extreme cases cause rail-tilt or rollout. See the following figure. Accordingly, inspectors should look for rail rollout due to rail seat abrasion on concrete crossties, particularly in territory with heavy traffic levels and moderate curvature. The mechanics of this condition on concrete crossties include the following elements:

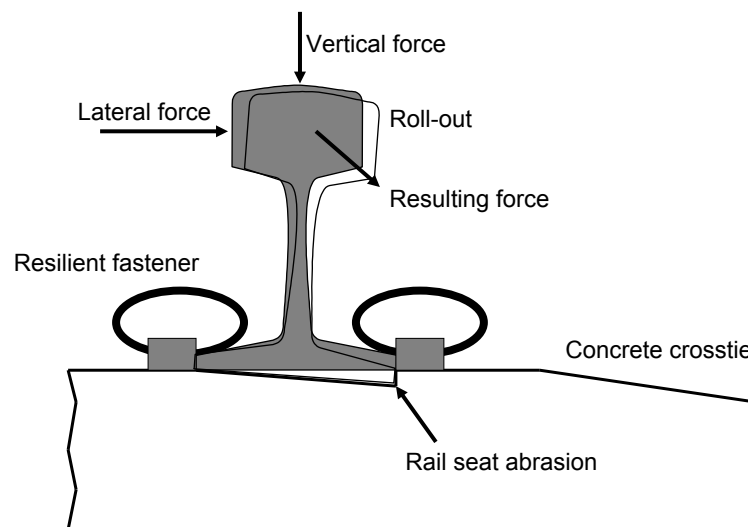

- Concrete wear or abrasion resulting in loose rail clips, insulators, and pads.
- Loose components allow more moisture and abrasives to enter rail seat.
- Once the field side of the rail base wears through the tie pad and contacts the concrete tie rail seat, rapid cutting into the concrete (accelerated abrasion) can occur.
- Signs and symptoms of concrete crosstie rail seat abrasion include.

- Tie pad crushed or squeezed out (maintaining integrity of the tie pad is essential).
- Insulators crushed, moving, or missing.
- Clips loose indicating loss of pressure on the rail base (loss of toe load).
- Longitudinal rail movement.
- Indications of cement colored paste in the ballast from the abraded rail seat.
- Metal flaking or grease streaks in the center of the low rail in a curve caused by the outer rim of wheel (or false flange) placing excessive pressure on the head of the rail, a condition generally created by gage-widening.

Based on the above discussion, it is apparent that rail-seat abrasion on concrete ties causes rail rollout. As rail rollout occurs, it decreases the effectiveness of the rail fasteners and will often lead to gage geometry conditions. As a general rule, inspectors should cite this condition as a rail fastener defect (213 defect code 0127A). However, where rail rollout causes the gage to exceed the threshold for the designated class of track, inspectors should cite this condition as a gage defect (see § 213.53).

Rail anchors are not considered to be a rail fastener. In areas where rail anchors are used in combination with resilient fasteners on concrete ties, the resilient rail fasteners that normally perform a dual function to restrain rail laterally and longitudinally should only be evaluated on their ability to provide lateral restraint to prevent gage-widening in regard to this section.

An insufficient fastener defect should be written when an unsafe condition results from missing or defective fasteners (e.g., heads of cut spikes sheared off at throat) on otherwise supportive crossties.

*(b) If rail anchors are applied to concrete crossties, the combination of the crossties, fasteners, and rail anchors must provide effective longitudinal restraint.*

**Guidance:** This paragraph requires that if rail anchors are applied to concrete crossties, then the combination of the crossties, fasteners, and rail anchors must provide effective longitudinal restraint. “Effective longitudinal restraint” is a performance-based standard.

*(c) Where fastener placement impedes insulated joints from performing as intended, the fastener may be modified or removed, provided that the crosstie supports the rail.*

**Guidance:** This paragraph addresses instances where fastener placement impedes insulated joints from performing as intended by permitting the fastener to be modified or removed, provided that the crosstie supports the rail. “Support” means that the crosstie is in direct contact with the rail or leaves an incidental space between the tie and rail. Certain joint configurations do not permit conventional fasteners to fit properly. As a result, manufacturers offer a modified fastener to fit along the rail so that the fastener provides the longitudinal requirement, or it is removed completely, providing lateral restraint is accomplished by ensuring full contact with the rail or additional placement of anchors on the base of the rail.

Additionally, FRA notes that the requirement of having an effective crosstie within a prescribed distance of a joint contained in § 213.109(e) would apply, without modification

for insulated joints. FRA has not mandated what type of equipment or what manufacturer a track owner must use, but instead has determined to regulate the performance of the material to the minimum safety standards promulgated in Part 213.

### **§ 213.133 Turnouts and track crossing generally**

*133(a) In turnouts and track crossings, the fastenings must be intact and maintained so as to keep the components securely in place. Also, each switch, frog, and guardrail must be kept free of obstructions that may interfere with the passage of wheels.*

**Guidance:** The rule specifies that all components and fastenings shall be intact and maintained securely in place. There are several types of fastenings, which include reinforcing straps, connecting rods, rail hold down clips, and braces. (For a more extensive compilation of fastenings, see the fasteners listed in defect codes 213.133.) Where fastenings are loose or missing, inspectors should cite the railroad using 213 defect code 0133A15 (Turnout or track crossing fastenings not intact or maintained.) In addition, where fasteners are loose or missing and there is an apparent contributing condition (e.g., a large section of the casting is broken out at an at-grade rail to rail crossing), inspectors should include a description of that contributing condition in their inspection report.

*133(b) Classes 3 through 5 track shall be equipped with rail anchoring through and on each side of track crossings and turnouts, to restrain rail movement affecting the position of switch points and frogs. For Class 3 track, this paragraph (b) is effective September 21, 1999.*

*133(c) Each flangeway at turnouts and track crossings must be at least 1½ inches wide.*

**Guidance:** A turnout is a track arrangement consisting of a switch and frog extending from the point of the switch to the heel of the frog. This arrangement allows engines and cars to pass from one track to another. Because of the operating or movable parts and lateral thrust, it is essential that fastenings be in place, tight, and in sound condition.

A track crossing (diamond) is an assembly used where two tracks intersect at grade permitting traffic on either track to cross the rails of the other. It may consist of four frogs connected by short rails, or a plant manufactured “diamond.” Because of the impact a crossing is subjected to, it is essential that fastenings be in place, tight, and in sound condition. Each switch, frog, and guardrail must be kept free of obstruction.

Anchors on each side of a turnout or crossing and through a turnout are required on Classes 4 through 5 track. For Class 3 track, this requirement is effective on September 21, 1999. In determining the adequacy of anchors at and on each side of a turnout or crossing and through turnouts, inspectors should determine the capability of these devices to:

- Restrain rail.
- Assure proper fit of switch points.
- Prevent line irregularities.

Ties and timbers at switches and crossings must be of sound condition, well-tamped, and the roadbed must be adequately drained.

Flangeways at turnouts and track crossings must be at least 1½ inches wide.

Turnouts and track crossings must be walked and measurements made before they can be included on the F6180.96 form as a unit inspected.

### § 213.135 Switches

*135(a) Each stock rail must be securely seated in switch plates, but care shall be used to avoid canting the rail by overtightening the rail braces.*

**Guidance:** The TSS under § 213.135 specifies the requirements for switch restraint, movement, and fit. Each stock rail must be securely seated in the switch plates. Various conditions, such as loose braces or hanging ties, can cause a stock rail to become unseated. In these situations, inspectors should cite the railroad with 213 defect code 0135A1. Alternatively, a stock rail can become unseated if the braces are overtightened during maintenance. In these situations, inspectors should cite the railroad with 213 defect code 0135A2.

*135(b) Each switch point shall fit its stock rail properly, with the switch stand in either of its closed positions to allow wheels to pass the switch point. Lateral and vertical movement of a stock rail in the switch plates or of a switch plate in a tie shall not adversely affect the fit of the switch point to the stock rail. Broken or cracked switch point rails will be subject to the requirements of §213.113, except that where remedial actions C, D, or E require the use of joint bars, and joint bars cannot be placed due to the physical configuration of the switch, remedial action B will govern, taking into account any added safety provided by the presence of reinforcing bars on the switch points.*

**Guidance:** This paragraph recognizes the existence of reinforcing bars or straps on switch points where joint bars cannot be applied to certain rail defects, as required under § 213.113(a)(2), because of the physical configuration of the switch. In these instances, remedial action B will govern, and a person designated under § 213.7(a), who has at least 1 year of supervisory experience in track maintenance, will limit train speed to that not exceeding 30 mph or the maximum allowable under § 213.9(a) for the appropriate class of track, whichever is lower. Of course, the person may exercise the options under § 213.5(a) when appropriate.

Section 213.135(b) addresses cracks in the switch rail (point) with reinforcing straps acting as surrogate joint bars. If the switch point rail is not cracked, and only the straps are cracked, then it is not appropriate to cite § 213.135(b); and inspectors should cite the appropriate defects under § 213.133(a). Normally, minor cracks in a strap are not a major concern. However, if a strap is fully broken and causing other problems (e.g., loose switch clip, etc.), then § 213.133 (Turnouts and track crossing generally) would be appropriate. If the straps and switch point rail are both broken, then there is an unprotected rail break and inspectors should cite the appropriate defect under § 213.113.

Most industry standards call for a 4<sup>3</sup>/<sub>4</sub>-inch opening between the switch point and the stock rail, measured at the No. 1 switch rod. As components wear, “lost motion” will result. When the problem of elongated switch clip and/or rod holes is encountered, the switch rods may be adjusted at the clip (e.g., adjustable side jaw clips, rocker clips, etc.). Adjustment may also be accomplished at the switch stand depending on the design of the assembly. In some cases, lost motion may be compensated by the addition of properly designed shims between the switch clip assembly and the switch rail.

When the opening is substantially less than the standard dimension, wheels can still pass through the switch as intended. However, the backs of wheels may contact the inside rail head of the open switch rail. This interaction can cause undesirable lateral pressure against the switch rail. This pressure can contribute to broken heel block bolts, cause cracked or broken switch clips, and broken switch crank cross pins. In extreme circumstances, the closed point can open under movement because of the transfer of lateral loads through the switch rods. In these circumstances, inspectors should make an extra effort to determine the condition of all affected components. The amount of throw is one of the many factors that must be taken into consideration when determining the railroad's compliance with §§ 213.133 and 213.135.

Based on the above, make sure that switch points fit snugly against the rail when the switch is thrown in either position. As appropriate, request that the railroad representative operate the switch to test for lost motion and/or loose connections.

The Appendix to the American Railway Engineering and Maintenance of Way Association (AREMA) Portfolio of Trackwork Plans contains the following split switch terms:

- “Split Switch with Uniform Risers - A split switch in which the switch rails have a uniform elevation on riser plates for the entire length of the switch, and therefore not having a heel slope, the point rail rise being runoff back of the switch in the closure rails.”
- “Split Switch with Graduated Risers - A split switch in which the switch rails are gradually elevated by means of graduated riser plates until they reach the required height above the stock rail, and therefore having a heel slope.”

The heel of the switch point is higher than the stock rail at the heel joint with the uniform riser layout while, on the graduated layout, the switch point is at the same elevation as the stock rail. The mixing of uniform riser and graduated riser plates in the same switch, while not specifically addressed in the TSS, can cause undesired stress in the switch rails and closure rails. Inspectors should make a note of the intermixing of switch plates in turnouts that have a high amount of traffic.

*135(c) Each switch shall be maintained so that the outer edge of the wheel tread cannot contact the gage side of the stock rail.*

**Guidance:** Inspectors are to examine the seating of stock rails in the switch plates to ensure that the outer tread of a wheel cannot engage the gage side of these rails. Grease lines or slight grooves running at a slight angle on the tread of a stock rail can provide inspectors with clues about the wheel/rail interface. These marks can be found in the area where wheel treads transition from the switch rail to the stock rail. When found, inspectors should closely examine the gage side of the stock rail to make sure the outer edge of wheel treads are not contacting the gage side of the stock rail. As shown in the following figure, this type of defect can occur when a worn switch rail and switch plates remain in place after a stock rail has been renewed. This causes the switch rail to drop down from the same level as its corresponding stock rail. The danger associated with this condition is the possibility that the outer edge of a wheel can contact the gage side of the stock rail during a trailing movement through a switch, thereby turning over the stock rail.



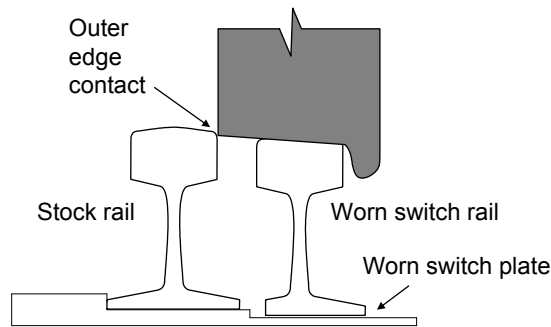

Other items that can cause outer edge wheel contact include improper surface, poor crosstie condition, loose rail braces, stock rails not securely seated, switches where the majority of the traffic uses one side of the turnout, and insecure jointed heel blocks with improper elevation.

*135(d) The heel of each switch rail shall be secure and the bolts in each heel shall be kept tight.*

**Guidance:** At least two tight bolts in each rail are required to ensure that the heel of each switch rail is “secure” for purposes of determining compliance with § 213.135(d). Examine the heel assembly, its fastenings, and bars, along with the surface condition of the heel. Improper elevation of the heel assembly relative to the stock rail can lead to outer edge wheel contact and excessive vertical movement of the switch point.

If heel joints were considered to be a normal joint, only one bolt per rail end would be required in the heel for Class 1 track. However, the heel joint functions in a different manner than a normal track joint. The heel joint serves as the pivotal point for the rotation of the switch point. It helps maintain the proper horizontal, vertical, and longitudinal fit of the switch point against its stock rail. One bolt per rail end in Class 1 track at the heel joint does not provide redundancy. The loss of the single bolt in the rail end at the heel joint could have serious safety consequences.

Some railroad heel joints have as many as six bolts for the higher track classes. Typically, when railroads plan to field weld, they do not drill the middle two bolt holes in the rail of a six-hole joint bar. This practice, which provides for at least two bolts in each rail end of the heel, satisfactorily secures the assembly.

The switch heel assembly with joint bars also performs the function of a joint. As such, where there is an improper joint bar at a heel block, an inspector should cite § 213.121 (Rail joints). One example of an improper joint bar is the installation of a six-hole joint bar where a five-hole bar, by design, should be used. This would be a deviation of § 213.121, because it is an improperly designed bar for that application, which may make it difficult to throw the switch or may cause gapping.

*135(e) Each switch stand and connecting rod shall be securely fastened and operable without excessive lost motion.*

**Guidance:** For hand-operated switch stands of virtually all types, rotary motion imparted to the vertical spindle within the stand by the person operating the hand lever is translated into

(practically) linear movement of the connecting rod by the right angle combination of the end of the spindle beneath the stand and its attached crank. Unless cranks are integrated with the spindle by casting during manufacture, they are separate pieces that must be joined. Cranks are attached to spindles in one of two ways: (1) they may be turned into a threaded opening in the side of the spindle or (2) the crank may be fabricated to have a square or rectangular smooth opening at one end, which can be moved from below, up onto a spindle having a similar cross-section to a position where it can be secured in place by a horizontally inserted cross pin that simultaneously engages the crank with the spindle. For ease of reference in this discussion, the first case will be referred to as Type A and the second case as Type B. An undesired decoupling of the connecting rod and the switch stand can occur in Type A if the bolt attaching a connecting rod to a threaded crank comes out and, in Type B, separation of the crank and the spindle can occur in the absence of the cross pin. Either instance could result in the gapping of the closed switch point under train movement, unless some other device is in place to physically restrain the points.

Type B switch stands may at times have a plate-like arrangement of sheet metal suspended from the headblock timbers beneath the assembly. This device, generally a shallow “U” shape, is commonly referred to as a “safety plate.” The function of the plate is twofold: (1) to restrict the downward movement of the crank on the spindle, should the cross pin be absent, so the crank does not completely separate from the spindle, and (2) to keep a vertically unrestrained crank from sliding down the spindle far enough to permit the connecting rod enough space below the bottom of the switch stand to move up off the lug of the crank. There have been cases where cross pins have fractured. The plate itself is deformed so that the downward displacement of the crank was sufficient to enable the connecting rod to clear the crank lug without contacting the base of the stand. This leads to decoupling of the switch stand and the connecting rod.

Inspectors must constantly bear in mind those aspects of switch stand performance that are crucial to functional safety. This discussion concentrates on that region of the mechanical linkage between the switch points and the switch stand that may be difficult to observe in the course of a turnout inspection.

There are several different styles of Type B switch stands that are in use on main tracks and yards in the railroad industry. These models differ in minor ways. Nevertheless, they rely on the cross pin restraint of the spindle/crank subassembly and they all share vulnerability to the uncoupling of the switch stand and connecting rod. A turnout inspection must include examination of these hard to see parts even.

Inspectors should examine the effectiveness of the fastening system of the switch stand to the head block ties and look for signs of movement of the switch stand which can result in loss motion leading to a gapped switch point.

*135(f) Each throw lever shall be maintained so that it cannot be operated with the lock or keeper in place.*

**Guidance:** Inspectors must examine each switch lock and keeper. Certain types of switch stands “internally toggle” when the handle is thrown all the way in either position to hold the switch point against its stock rail. These types of switch stands are used in other than main track and often are a “semi-automatic” design whereby a train trailing the turnout, with the switch in the incorrect position, will initially force the points over. The final throw is

completed by the internal toggling action of the switch stand. By design and application preference, these switch stands might not have a lock or keeper for other than main track applications (see the following figure).

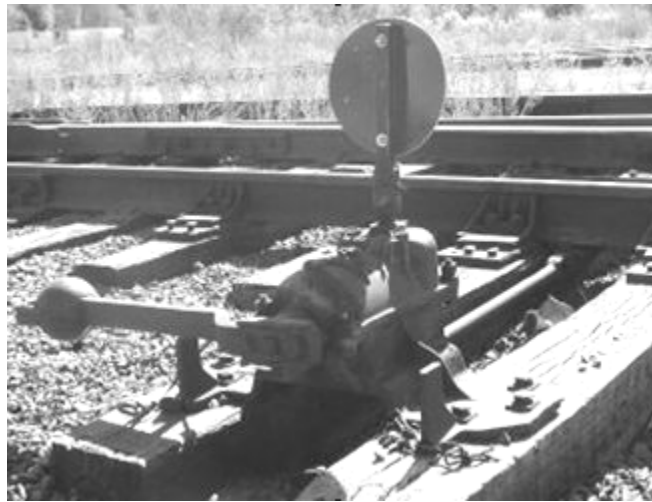

There is a concern associated with this type of switch stand retrofitted with an “S”-shaped strap, bolted and welded to one of the two flanges of the throw lever stop. The bolt has been proven to be ineffective in preventing rotation of the strap, and the bead weld, placed by the manufacturer at the top of the strap, cracks from repeated depression of the keeper. The strap rotates downward, altering the location of the lock shackle or keeper, allowing the throw of the switch lever without removal of the lock or keeper.

If the above types of switch stands are used at switches and derails not requiring securing, the soundness of the strap is not in question. However, if the track owner requires that the stand be secured by lock or keeper, a weld displaying cracks will call into question the soundness of the latch mechanism and 213 defect code 0135F, *throw lever* (potentially) operable with switch-lock or keeper in place, should be cited without recommending a violation. If the track owner fails to aggressively address and correct the potential defect on the subject types of switch stands, consider recommending a violation to Chief Counsel.

49 CFR 218.105(b) requires that all hand operated main track switches are to be locked. An ineffective or worn latch or hasp can allow the throw lever of the switch to be operated with the lock in place. There are several different types and models of hand operated switches in use; Inspectors should inspect each latching mechanism to for wear and possible operation of the throw lever with the lock in place. The inspection should include stepping on the latch and observation of the clearance between the throw lever and the opening created when the latch is depressed with lock in place. Inspectors should not attempt to raise the operating lever and request the accompanying railroad representative to lift the handle if its operation through the latch appear probable, and it is safe to do so. As shown in figure below, the throw lever is clearly operable with the lock in place.

Many power switches are operable by either power (remotely by control operator or train dispatcher) or by hand, frequently called dual control switches. Inspection of this type of switch machine is similar to the typical hand operated switch stand. Most have two levers, one to remove the switch machine from power operation, and one that acts as the throw

lever. The latches should be inspected for the possibility of the power lever or throw lever being operated with the lock in place. (See the following two figures)



*135(g) Each switch position indicator shall be clearly visible at all times.*

**Guidance:** Examine condition of switch position indicator and note any unnecessary obstruction to its visibility. This requirement does not mandate that every switch have a position indicator but merely requires such devices to be clearly visible when installed on a switch stand.

*135(h) Unusually chipped or worn switch points shall be repaired or replaced. Metal flow shall be removed to insure proper closure.*

**Guidance:** The rule does not provide for specific dimensions for determining when switch points are “unusually chipped or worn.” The accident/incident database indicates that worn or broken switch points are the largest single cause of derailments within the general category of “Frogs, Switches, and Appliances.” However, most of these derailments are related also to other causal factors such as wheel flange condition, truck stiffness, and train-handling characteristics. Therefore, qualified individuals must use their experience to determine when switch points are “unusually chipped or worn.”

*135(i) Tongue & Plain Mate switches, which by design exceed Class 1 and excepted track maximum gage limits, are permitted in Class 1 and excepted track.*

**Guidance:** This paragraph provides an exemption for this item of specialized track work, primarily used in pavement or street railroads, which, by design, does not conform to the maximum gage limits prescribed for Class 1 and excepted track. This type of special work is fabricated from “girder rail,” which includes a tram (flangeway) rolled into the rail section. A “mate” is similar to a frog but located on the side of the switch that is equivalent to a straight stock rail. The switch, when in the open or curved position, guides wheels past the mate on the turnout (curved) side in a manner similar to a frog guardrail.

**Guidance, General.** In addition to considering the above criteria, inspectors must perform the following when inspecting switches:

- Check alinement, gage, and surface.
- Examine condition as to the wear of switch points and stock rails.

- See that all bolts, nuts, cotter pins, and other fastenings are in place, in good condition, and are properly tightened;
- See that switch points fit snugly against the rail when the switch is thrown in either position. Request that the railroad representative operate switches to test for lost motion and/or loose connections.
- If applicable, examine the rod and fastenings that connect the switch point to the switch circuit controller to ensure they are in place and in good condition.
- Examine the condition and support of spring and power-switch machines and hand-thrown switch stands, including automatic or safety switch stands. Switch stand and machine fastenings to the head block ties must be tight to avoid any movement or play.
- Examine switch-lock and keeper.
- Examine condition of switch position indicator and note any unnecessary obstruction to its visibility.
- Examine the heel block, its fastenings, and bars; or, in the absence of a heel block, examine the floating heel of the switch point.
- Examine the seating of stock rails in the switch plates to ensure that the outer tread of a wheel cannot engage the gage side of these rails and that chairs or braces do not cant these rails in. This defect is particularly a problem for travel in the direction from the frog to the switch (trailing movement). Grease lines or slight groves running at a slight angle on the tread of a stock rail can provide inspectors with clues about the wheel/rail interface. These marks can be found in the area where the wheel tread transitions from the switch rail to the stock rail. When found, inspectors should closely examine the gage side of the stock rail to make sure the outer edge of wheel treads are not contacting the gage side of the stock rail.
- Examine the gage plates and switch rods.

### § 213.137 Frogs

*137(a) The flangeway depth measured from a plane across the wheel-bearing area of a frog on Class 1 track may not be less than 1 $\frac{3}{8}$  inches, or less than 1 $\frac{1}{2}$  inches on Classes 2 through 5 track.*

**Guidance:** The Association of American Railroads (AAR) Field Manual of Interchange Rules states that a wheel is condemnable when the flange height is “1 $\frac{1}{2}$  inches or more above the approximate center line of the tread.” The AREMA Portfolio of Trackwork Plans, Point and Flangeway Dimensions, provides a designed flangeway depth of at least 1 $\frac{7}{8}$  inches. Therefore, the amount of clearance between a worn wheel with a high flange and the bottom of a new frog’s flangeway may be as little as three-eighths inch. At higher speeds, if a worn frog has a flangeway less than 1 $\frac{1}{2}$  inches, the wheel flange could “bottom out” in the flangeway and result in severe damage to the frog.

Section 213.137(a) permits a flangeway depth of 1 $\frac{3}{8}$  inches in Class 1 track. In such a condition, a wheel that is approaching condemning limits might contact the bottom of the flangeway. As such, it is possible to have evidence of wheel flangeway contact on the bottom of the flangeway caused by compliant wheels.

*137(b) If a frog point is chipped, broken, or worn more than  $\frac{5}{8}$  inch down and six inches back, operating speed over that frog may not be more than 10 m.p.h.*

**Guidance:** If a frog point is chipped, broken, or worn more than five-eighths inches down and 6 inches back, a collapse of the point area is possible after repeated wheel impacts. This parameter requires a defect to be more than five-eighths inches down from the original profile to a location 6 inches back toward the heel to be considered. For example, a frog point that is seven-eighths inches below its original profile at the actual frog point and seven-eighths inches below at a position 6 inches back toward the heel of the frog would be a defect.



For a severe condition that would not meet this criteria such as a breakout at a frog point that is only 4 inches in length and greater than five-eighths inches down, inspectors may consider using the 213 defect code 0137E.

While this condition may not be a defect, it is a method to notify a railroad of a condition that the inspector feels the structural integrity of the frog is in question. Please note that 213 defect code 0137E does not link to a paragraph in the TSS and may only be used as an advisory to the railroad.

Another possible result of a severely worn frog point, especially when coupled with a worn or loose guardrail, is that a railroad wheel may “hit” the point and climb to the wrong side of the frog. Also see figure in paragraph 137(c) below for information about “depressed point” designs that may influence the measurement of a worn or broken frog point.

*137(c) If the tread portion of a frog casting is worn down more than  $\frac{3}{8}$  inch below the original contour, operating speed over that frog may not be more than 10 m.p.h.*

**Guidance:** This paragraph specifically refers to the amount of tread wear from the original contour of the casting. The original contour can be determined in a variety of ways depending upon the frog design.

The tread of the frog is considered to be any portion that is contacted by the tread of the wheel except for portion of the frog from the actual point to a position 6 inches back towards the heel [this area is addressed by § 213.137(b)]. As shown in the following figure, the measurements of the portion of the tread further back than the 6 inch position may be taken by placing a straightedge positioned transversely. The following figure shows a rail bound manganese frog design with an actual frog point that is three-sixteenths inch lower than the

tread portion. A frog built without manganese insert (e.g., a frog composed of Tee rails called a bolted rigid frog) will have a point with a similar profile. Called a depressed point, the tread will taper up to the top of the rail profile in the direction toward the frog heel in varying distances depending upon the different manufacturing designs and size of frogs, but not less than 5 inches.

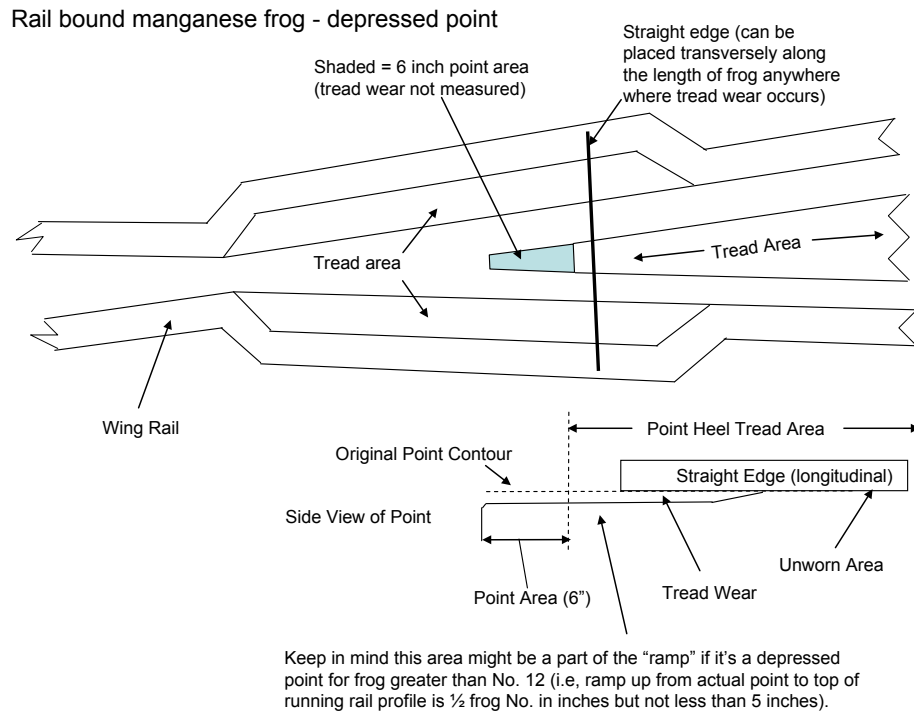

An alternate rail bound manganese or solid cast frog design includes a profile whereby the tread portion of the casting adjacent to a frog point is manufactured to a plane one-eighth inch above the top of the rail profile (wing wheel riser). See following figure. These design characteristics need to be considered when measuring tread wear as discussed below.

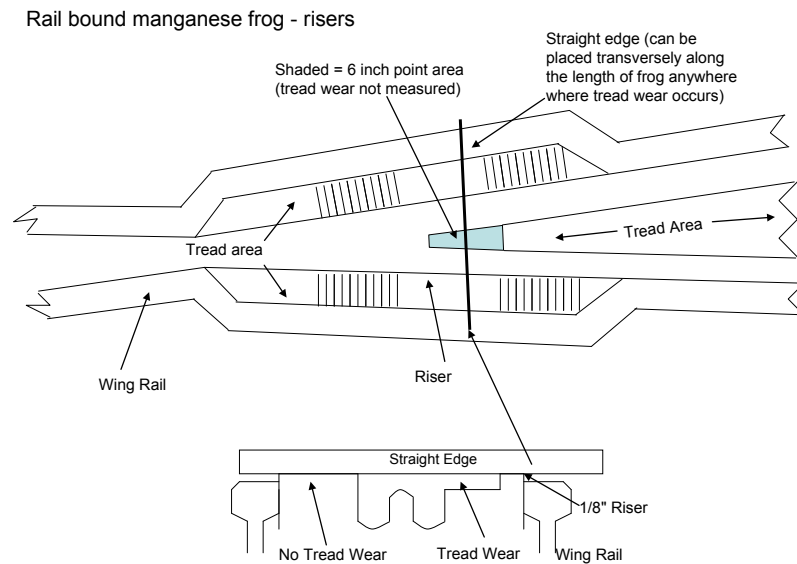

When measuring tread wear, the distance from the bottom of the straight edge to the worn tread at the riser is measured. Various types of gauges, such as a folding leaf gauge with different degrees of taper, or a wedge-type gauge, may obtain this measurement. Tape measures are also frequently used to measure tread wear.

There is a wide variety of new frog designs being developed and used in the industry that may require different measuring techniques or tools and must be given consideration; one example is the conformal frog. The design of the conformal frog casting through the original tread and point area is tapered to the same angle (1:20 ratio) as the tread of the wheel to reduce impact load and smooth wheel transition. The wing or transition portion of the casting of a conformal frog is raised and extends above the wrap or wing rail of the frog. Measuring the amount of wear on a conformal requires use of a special "straight edge" to properly measure tread, point, and flangeway depth due to the "conformal" design. Use of a standard straight edge on a conformal frog may result in improper wear limit measurement.

If the tread is worn more than three-eighths of an inch, the corresponding flangeway depth may also be reaching critical limits. Since the manganese insert is typically designed to be about 2 inches thick at the wall of the flangeway and about  $1\frac{3}{8}$  inches or less at the bottom of the flangeway, wear in this condemning range could result in structural failure of the frog.

Frogs frequently exhibit small spalling (pitting) in the tread. Usually, this type of spalling is not hazardous. Measurements of tread wear should be made over a length that is worn down due to abrasion or plastic flow of metal not at the bottom of small spalls. However, if the depression is of sufficient size to permit the tread of a wheel to follow that depression, tread wear should be measured at the depression.

To measure flangeway depth, place a straight edge across the frog at the area of concern. Measure the space between the underside of the straight edge to the bottom of the flangeway and the space between the underside of the straight edge and the tread. As



shown in the following figure, subtract the tread value from the flangeway value to obtain the actual flangeway depth.

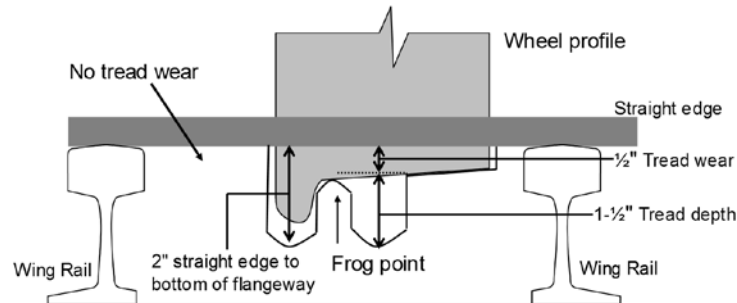

When a railroad wheel approaches the frog in the facing direction, the weight of the wheel is supported on the tread of the frog opposite the point until the wheel reaches the transition point, about 6 inches back from the actual point. At this location, the weight is transferred to the frog point.

*137(d) Where frogs are designed as flange-bearing, flangeway depth may be less than that shown for Class 1 if operated at Class 1 speeds.*

**Guidance:** This paragraph provides an exemption for an item of specialized track work that by design does not conform to the minimum flangeway depth requirements prescribed in paragraph (a) of this section. Called a flange-bearing frog, this technology is under consideration as a method of reducing impact loads at frogs. This design is a new concept for track above yard speeds but has been used extensively in light rail transit trackwork.

There are a number of frog designs in use throughout the industry and the most common types are rail bound manganese and bolted rigid (stiff). The special attributes of spring frogs are covered under § 213.139. Conventional moveable point frogs are found at flat angle track crossings and slip switches (see the figure below). This type of movable point frog is similar to a switch because of its movable points that fit against a knuckle rail, which is like a stock rail.

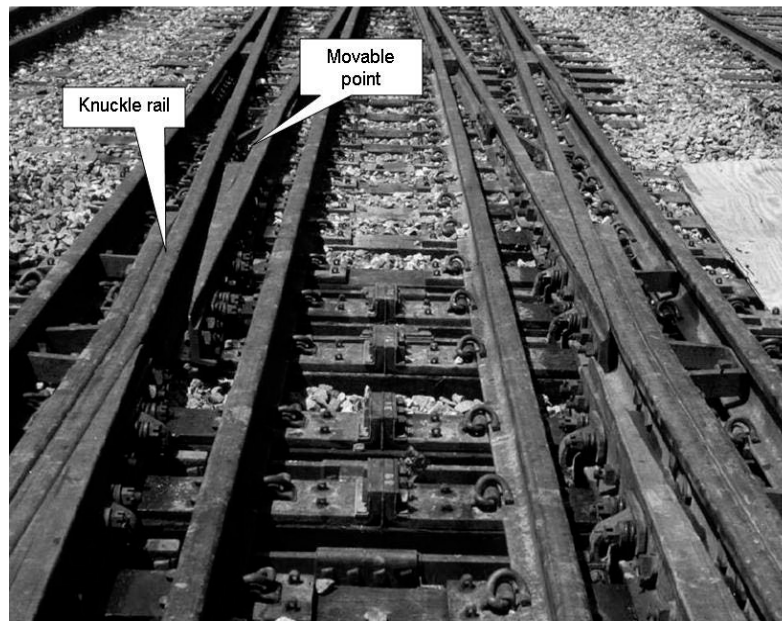

Conventional Moveable Point Frogs

In recent decades, new technology movable frogs have been introduced in the Nation and there are two types—“swing nose” (the left figure below) and movable wing (the right figure below). Conventional movable point frogs and swing nose frogs are virtual switches; therefore there are no guardrails. As such, it is appropriate to use the applicable elements of § 213.135 (Switches) in an inspection report when encountering defects in these movable point frogs. For example, a movable point that does not fit its knuckle rail properly would be covered under § 213.135(b) (each switch point shall fit its stock rail properly).

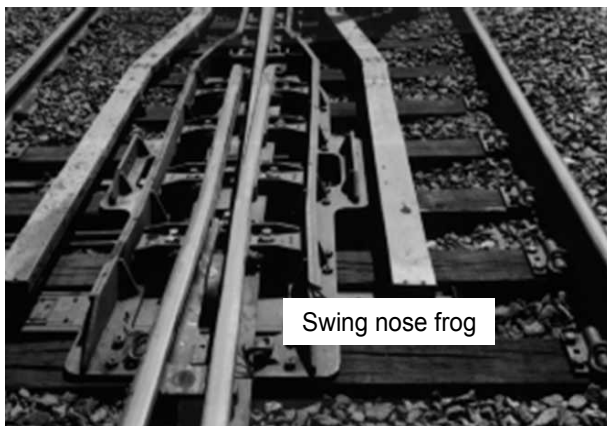

The movable wing rail type frog is similar to a spring frog but both wing rails are moved remotely in synchronization with the switch points. It is appropriate to use the applicable elements of § 213.139 (Spring rail frogs) in an inspection report when encountering defects. Like above, when using any of the 139 series defect codes it is necessary to include 213 defect code 0133A15 – Turnout or track crossing fastenings not intact or maintained.

The following are the key elements to consider when inspecting new technology frogs:

- Bolting or fastener designs that fasten the movable point frog to concrete or timber switch ties are considered fasteners in the same manner as cut spikes. Fastenings are discussed under § 213.127 of this manual. Bolts that connect movable frog components together are considered frog bolts and must be addressed by using 213 defect code 0133A12, Loose or missing frog bolts.
- Of paramount importance is a proper fit of the V-point rails against the wing rails on movable frogs. Inspectors must use their judgment to determine if the point fits the wing rail properly to allow wheels to pass the frog point. Movements of the wing rail must not adversely affect the fit of the frog point to the wing rail. When an inspector encounters a condition on a movable frog which should be addressed on the inspection report and no existing code is available for that condition, 213 defect code 0137E will be acceptable with a full description of the condition in the inspection report.
- Unlike rail bound manganese frogs, the running surface of most, if not all, movable frogs are made of hardened rail. Inspectors must be aware that this rail may contain defects that require remedial action under § 213.113. Asymmetrical rails found in some switch points and frogs must be closely examined during inspections, as this appears to be a potential weak spot where a crack or break could occur.
- When performing inspections, FRA inspectors should discuss any concerns about an advanced turnout with appropriate railroad personnel. Inspectors should consult with the regional track specialist to resolve any questions about the safety of these installations.

**General Guidance:** The various types of frogs available for specific applications include bolted rigid, solid manganese, self-guarded, railbound manganese, spring rail, movable point, cast, or swing nose. On railbound manganese frogs, the normal wear pattern is in the manganese insert.

An inspector, in addition to measurements described in the TSS, should see that a frog is supported throughout on well tamped and sound ties.

The requirements for flangeway depth in paragraph (a) and the requirements for tread wear in paragraph (c) also apply to crossing frogs. Since the designed flangeway depth is also  $1\frac{1}{8}$  inches, the safety concerns are the same, as excessive wear on the tread portion could result in a wheel flange striking the bottom of the flangeway and causing structural damage to the frog.

Inspectors must evaluate cracks or breaks in frog castings or rail defects in the non-running portion of wing rails in terms of their potential effect on the safe passage of rolling stock. In particular, when making the evaluation:

- The inspector should determine if there is a loss or imminent loss of wheel guidance due to a loss of functional integrity.
- The inspector should not consider cracks or breaks in a manganese frog casting that do not affect the safe passage of rolling stock to be a defective condition. If a severe crack, or a series of cracks, creates a condition where the breaking out of a piece of the casting is imminent, the use of 213 defect code 0137E should be considered. Cracks or wear that develop into a loss of functional integrity should be addressed by using 213 defect code 0137B or 0137C, which govern worn frog points and castings.

- Rail defects in the non-running portion of wing rails should be addressed by using 213 defect code 0137E.

### § 213.139 Spring rail frogs

139(a) *The outer edge of a wheel tread shall not contact the gage side of a spring wing rail.*

**Guidance:** Inspectors must closely examine every spring rail frog encountered during an inspection. While spring rail frogs have been successfully used for many years, their unique design requires special maintenance attention to avoid derailment hazards to trailing point train movements on the main track. If a spring wing rail is higher than the top running surface of frog at the transition area, a wheel during a trailing move may push the spring wing rail open causing rail roll out or wide gage. Hollow or false flange wheels are more prone to cause this occurrence.

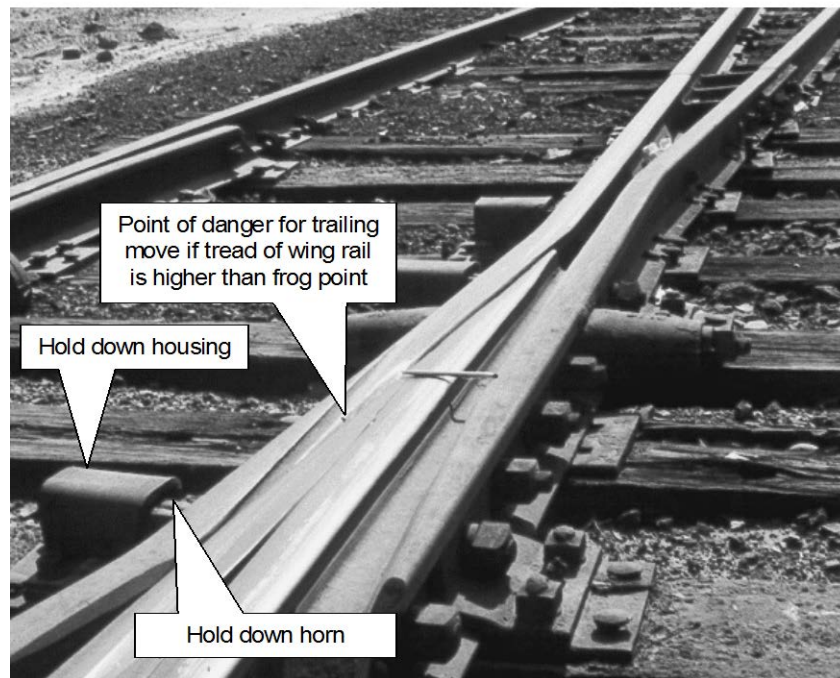

A beginning sign of outer edge wheel tread contact will appear as gouging on the gage corner of the wing rail behind the point of frog at the transition point similar to the stock rail/switch point configuration. While some spring frogs have a “relief” groove built into the frog for this purpose, inspectors must be acutely aware of any signs of the gage side of a spring wing rail being struck by the outer edge of wheel treads. Wheel gouging must not be confused with channeling in the spring wing rail that is incorporated at the time of manufacture to accommodate wheel tread transition. Vertical deflection at the toe of frog (213.139(b)) and hold-down housing clearance (213.139(e)) must be assessed when gage face wheel contact is observed. If the toe is not solidly tamped and excessive horn and housing clearance exists, the wing rail may have vertical motion while wheels are operating on the point rail in a trailing-point movement and the forces on the wing rail will cause the wing rail to move laterally, allowing the wheel to drop in at the throat of the frog.

139(b) *The toe of each wing rail shall be solidly tamped and fully and tightly bolted.*

**Guidance:** The toe of each spring rail frog must be solidly supported, and proper hold-down housing clearance must be maintained to avoid excessive vertical movement of the wing rail. The combination of these two conditions can cause outer edge wheel tread contact. The first sign that this is occurring will be gouging on the gage corner of the wing rail behind the point of frog. Wheel gouging must not be confused with channeling in the spring wing rail that is incorporated at the time of manufacture to accommodate wheel tread transition.

If the toe is not solidly tamped and excessive horn and housing clearance exists, the wing rail may have vertical motion operating on the point rail in a trailing-point movement and the forces on the wing rail will cause the wing rail to move laterally, allowing the wheel to drop in at the throat of the frog.

*139(c) Each frog with a bolt hole defect or head-web separation shall be replaced.*

**Guidance:** Any bolt hole defect or head-web separation in a spring frog of any dimension constitutes a defect. This paragraph does not prescribe a corrective action other than “replacement.”

*139(d) Each spring shall have compression sufficient to hold the wing rail against the point rail.*

**Guidance:** The intent of the regulation is to ensure the spring holds the wing rail against the point rail. Typically, if a wing rail is up against the point, it is an indication that the spring is holding it as intended. If an inspector finds the wing is not against the point he/she should determine the root cause of the condition. A component such as loose bolt may be obstructing the closure and 213.133A12 should be cited. Without proper anchorage, the horn may bind in the hold-down housing and defect 213.133B should be cited in track classes 3-5. If there is a suspicion that there is insufficient compression in the spring, the railroad representative should determine its compliance.

*139(e) The clearance between the hold-down housing and the horn shall not be more than ¼ inch.*

**Guidance:** Since the spring wing rail is a movable part of a spring frog, it cannot be fastened down. The hold-down housing and a horn assembly prevents the wing rail from moving up higher than the top of the tread at the transition point. The following figure illustrates the proper method to determine if there is excessive space between the hold-down housing and the horn.

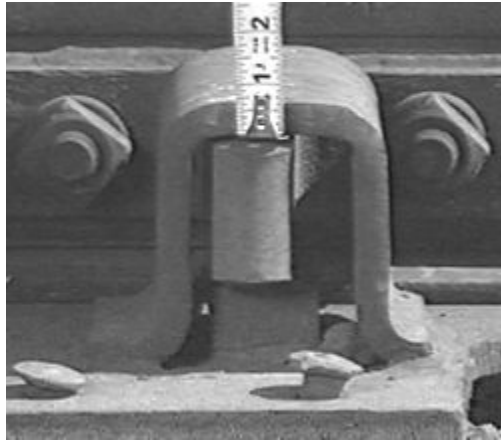

**General Guidance:** Due to the unique design characteristics of spring frogs, turnouts with this type of appliance require special consideration in regard to guardrails. On the main track side of a turnout, when trains are not “springing” the frog (by design) and operating on an unbroken path, an extra length guardrail assures a proper path for wheelsets.

A guardrail should be of sufficient length to cover the designed hinge length. This keeps wheels off the spring wing rail from the point where this rail is “hinged” through the frog throat and finally to the actual frog point.

While the TSS does not address this design concept, inspectors should be aware of this attribute of spring frogs. If a guardrail is of insufficient length to cover the designed hinge length, any lateral wheel forces can cause significant problems. Specifically, the guardrail and other frog elements will quickly deteriorate, and in extreme circumstances, the wing rail can open while trains are moving through the main track side which can result in an unprotected wide gage. Inspectors should note on their inspection report any guardrail on a spring frog that is not of the proper length or installed in the improper position.

Another special consideration with regard to spring frogs is the longitudinal relationship between the spring wing rail and frog point. If a turnout has insufficient rail anchors to restrain longitudinal movement, the wing rail may not function properly. Evidence that longitudinal movement is occurring may be a gap between the wing rail and the frog point. Inspectors are reminded to refer to § 213.133(b) that requires Classes 3 through 5 track to be equipped with sufficient rail anchoring to restrict longitudinal rail movement. If longitudinal movement is observed because of insufficient anchors on Classes 1 and 2 track, inspectors are encouraged to note this condition and inform the railroad.

Spring frogs are manufactured with a steel base plate. Attached to the base plate are clip plates, which are placed along the fixed side of the frog. The clip plates, which are shaped into a right angle, are attached to the base plate by bolts, welds, or both. Frog bolts are placed through the body of the frog and through the vertical portion of the clip plates and tightened. This holds the body of the frog to the clip plate assembly.

There are no gage holding fasteners along the movable side of the frog as they would interfere with the spring wing rail. Therefore, it can be seen that the frog bolts and clip plate assemblies, acting together, maintain alinement of the spring frog. Care should be taken to

ensure that the frog bolts and clip plate bolts are in place and tight (213 defect code 0133A12). Also check clip plates to see if welds are cracked or broken and check clip plates for cracks and breaks at the corner where the plate bends from horizontal to vertical. Where cracks or breaks in clip plates affect the fastening of the frog to the base plate, use defect 213 code 0133A15 (insufficient fasteners).

In recent years, railroads have augmented the design of spring frog installations by the application of improved stops to limit the amount of movement of the spring rail. In addition, some frogs have been retrofitted with welded stops. Most stops are designed to allow the wing to open no more than  $1\frac{7}{8}$  to  $2\frac{1}{4}$  inches. When stops are properly installed, the risk of trailing point derailments is reduced.

When spring frogs are equipped with the improved features, such as relief grooves and stops, the inspector should evaluate the condition of the components in order to ascertain that the improved features are functioning as intended.

When spring frog defects are found, the defective conditions must be repaired as soon as possible. Combinations of the defects are especially hazardous. The railroad must protect the movements over the frog with a speed restriction until the defects are repaired.

Spring frog defects are considered as non-class-specific defects (see § 213.9); therefore, inspectors must consider the circumstances involved in evaluating the remedial action taken by the railroad when spring frog defects are found. Inspectors should consider all spring frog defects as serious defects that must be repaired as soon as possible. In most circumstances, when it is evident that the outer edge of the wheels are contacting the gage side of the wing rail or a combination of spring frog defects exist, inspectors would expect that the railroad would implement a speed restriction.

Some spring frogs are equipped with retarders that reduce the impact of the wing on the point as the wing closes with each passing wheel in the diverging route. The retarders may hang, causing the wing to remain open. Though the TSS does not address this design concept, inspectors should still be aware of this attribute of spring frogs because it could lead to further degradation of frog components.

### **§ 213.141 Self-guarded frogs**

*141(a) The raised guard on a self-guarded frog may not be worn more than  $\frac{3}{8}$  of an inch.*

**Guidance:** When examining self-guarded frogs, observe the condition of the frog point, and where there is evidence of wear caused by wheel flanges contacting the frog point, take measurements to determine compliance with this section. To determine the amount of wear on a raised guard, measure the thickness at a portion where there is wear. Compare this measurement to a portion where there is no wear and the difference between the two is equivalent to the amount of wear.

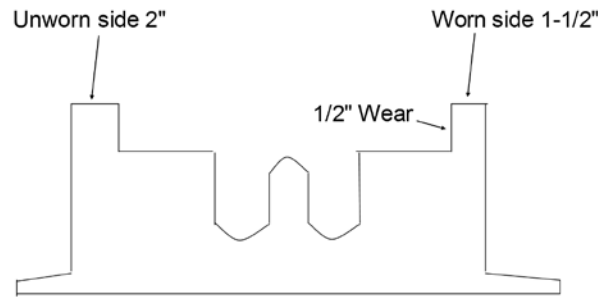

141(b) If repairs are made to a self-guarded frog without removing it from service, the guarding face must be restored before rebuilding the point.

**Guidance:** During repairs of a self-guarded frog, it is imperative that the raised guarding face is restored before the actual frog point. This precaution is necessary due to the potential for a wheel flange striking the frog point.

Self-guarded frogs are designed for use in low speed track and their use in tracks where speeds exceed 20 mph can result in excessive lateral forces such as wheels “kicking” or in extreme cases wheels climbing up the raised guard. The TSS does not prohibit the use of self-guarded frogs in any class of track; however, inspectors are encouraged to inform a railroad of the potential for problems that may occur if a self-guarded frog is found in a track where speeds exceed 20 mph.

**§ 213.143 Frog guard rails and guard faces; gage**

The guard check and guard face gages in frogs must be within the limits prescribed in the following table:

Class of track	Guard check gage <i>The distance between the gage line of a frog to the guard line<sup>1</sup> of its guard rail or guarding face, measured across the track at right angles to the gage line<sup>2</sup>, may not be less than</i>	Guard face gage <i>The distance between guard lines<sup>1</sup>, measured across the track at right angles to the gage line<sup>2</sup>, may not be more than</i>
1	4' 6 <sup>1</sup> / <sub>8</sub> "	4' 5 <sup>1</sup> / <sub>4</sub> "
2	4' 6 <sup>1</sup> / <sub>4</sub> "	4' 5 <sup>1</sup> / <sub>8</sub> "
3 & 4	4' 6 <sup>3</sup> / <sub>8</sub> "	4' 5 <sup>1</sup> / <sub>8</sub> "
5	4' 6 <sup>1</sup> / <sub>2</sub> "	4' 5"

<sup>1</sup>A line along that side of the flangeway which is nearer to the center of the track and at the same elevation as the gage line.

<sup>2</sup>A line <sup>5</sup>/<sub>8</sub> inch below the top of the centerline of the head of the running rail or corresponding location of the tread portion of the track structure.



**Guidance:** A guardrail is installed parallel to the running rail opposite a frog to form a flangeway with the rail and to hold wheels of equipment to the proper alignment when passing through the frog.

A guardrail must be maintained in the proper relative position to the frog in order to accomplish its critical intended safety function. Inspectors should examine guardrails carefully to see that they are adequately fastened, and when measuring guardrail gage, fully consider any movement of guardrail or frog under traffic conditions.

This section clearly specifies allowable tolerances for guard check and guard face gage for various classes of track.

When measuring guard check gage, it is important to consider the path of wheels through the frog because the function of a guardrail is to keep wheel flanges from striking the actual frog point. As reference, standard check gage on a railroad wheel set is approximately 54½ inches (see the following figure for approximate design check gage values). While the TSS minimum guard check gage is less than wheel check gage in lower classes of track, the condition of the actual frog point in relation to the path of wheels through a frog is a good indicator of the effectiveness of a guardrail.

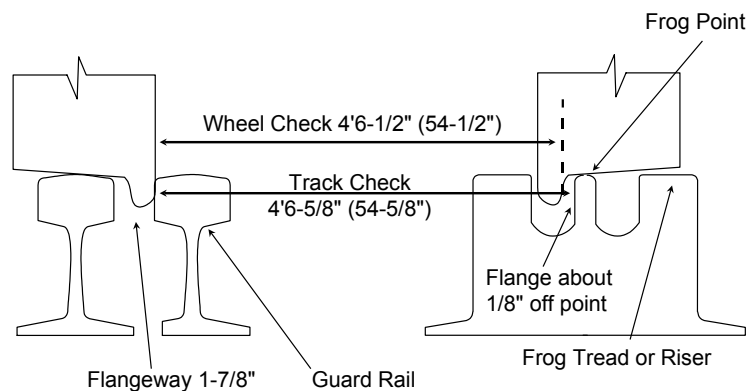

The critical area where guard check gage must be measured is at the actual point of frog. Inspectors must also consider any unusual wear that may exist at the actual frog point and position the track gauge or other measuring device accordingly.

When measuring guard check gage, dynamic lateral movement of the guardrail and/or frog shall be considered. In the case of a frog that is moving laterally under train movement (floating), it is important to consider the most restrictive measurement. Specifically, if measuring guard check gage in a turnout where the frog can move toward the track being measured due to train movement on the other track, that dynamic frog position would be considered. See the figure below.

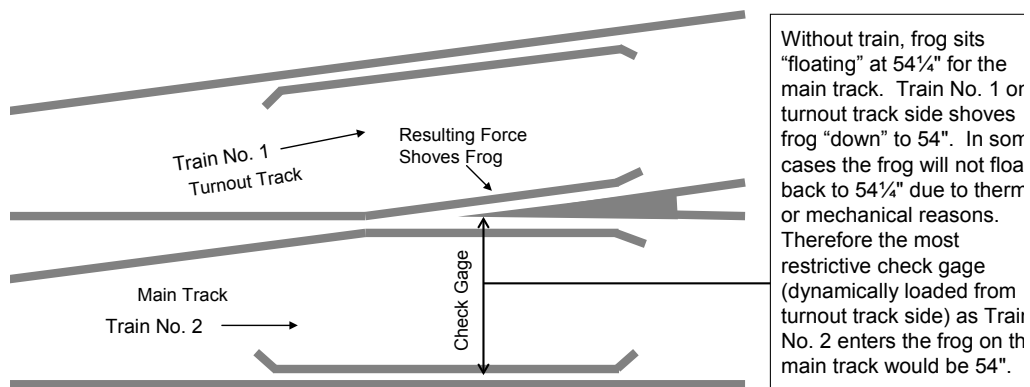

In severe cases, where a frog is severely floating (moving laterality under load) and there is an accompanying condition (i.e., deteriorated crossties or ineffective fasteners), FRA inspectors should cite the defect or recommend a civil penalty for the accompanying condition (i.e., §§ 213.109 (Crossties) or 213.127 (Rail fastenings)).

Face gage is a dimension that becomes critical when the distance between two opposing guardrails, or a guardrail and a frog wing rail, become larger than the distance between the back of wheelsets. This would occur by improper installation, or a condition such as a severe alignment defect. Normally, face gage would be measured in the same vicinity as check gage. However, inspectors should consider measuring face gage at other points in special trackwork where there may be an indication that wheels are being "pinched." For general reference, the following illustrates approximate design face gage values.

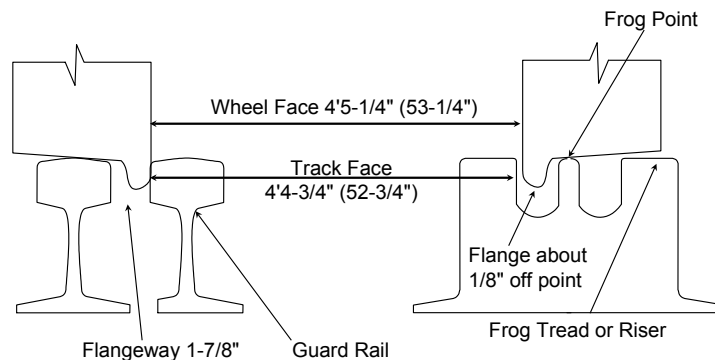

Broken guardrails occur infrequently, since they do not support the vertical wheel loads of passing trains. When evaluating a crack or break in a guardrail, the inspector should be aware that cracks or breaks exist that do not affect the ability of the guardrail to function as intended. If the integrity of the guardrail is affected, the inspector will cite the defect using 213 defect code 0143A3, Cracked or broken guardrail.

There are many different types and designs of frog guardrail designs. Some guardrail plates are recessed to seat the running rail, while others are flat. Some guardrail plates are punched with spike-hole slots; others are not. Other guardrails are bolted to the running rail. On some railroads, it is normal practice not to spike the gage side of the running rail

through the guardrail area while some guardrail plates do not have holes punched for this purpose. FRA has no record of serious safety problems that have developed as a result of not spiking the running rail through the guardrail area.

If encountering a problem where the running rail has moved laterally to create an unsafe condition, the inspector should use insufficient fasteners defect code 213.127. Inspectors should discuss unique situations with their regional track specialist.

While not a requirement of the TSS, guardrails have a straight portion that guides wheels through the area from the “throat” to the actual frog point. If inspectors find a guardrail where the straight portion does not encompass this area, inspectors should bring this to the attention of the railroad. The following figure illustrates the proper measurement points to determine check/face gage compliance and shows the proper longitudinal relationship between a guardrail and frog point.

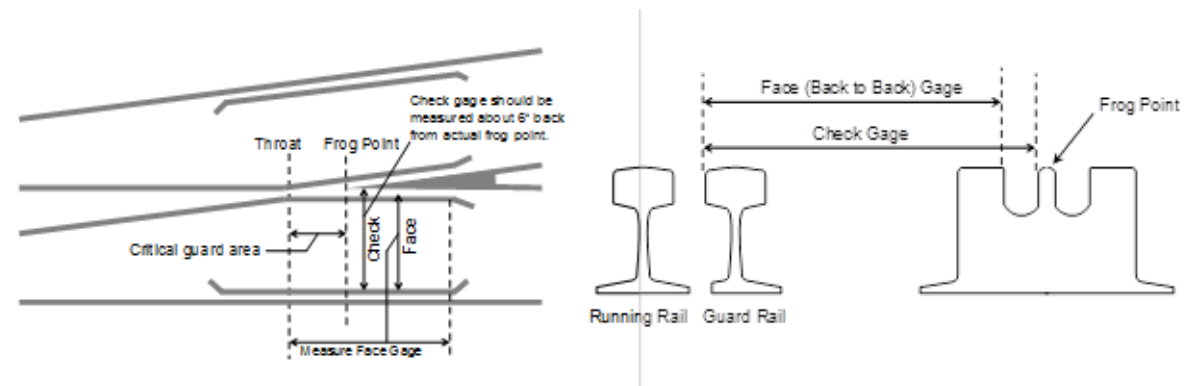

## Subpart E – Track Appliances and Track - Related Devices

### § 213.201 Scope

*This subpart prescribes minimum requirements for track appliances and track-related devices.*

### § 213.205 Derails

*205(a) Each derail shall be clearly visible.*

**Guidance:** The TSS requires derails to be clearly visible. Though the TSS does not specify a color derails are to be painted, they must be visible to railroad employees, and a derail dark in color and obscured by vegetation would not be in compliance.

*205(b) When in a locked position, a derail shall be free of lost motion which would prevent it from performing its intended function.*

**Guidance:** Inspectors will need to determine the extent of movement due to worn parts or improper adjustment, if any, and determine if such movement renders the derail ineffective.

*205(c) Each derail shall be maintained to function as intended.*

**Guidance:** Derails are of various designs and may be of the following types: switch point, spring switch point, sliding, hinged, and portable.

Derails can be operated by various means: electrical, hand throw, lever, and mechanical rod from a point other than at the derail. They should be installed to derail rolling stock in a direction away from the track or facility to be protected.

In addition to the requirements of this section, a switch point-type derail must also comply with the requirements of § 213.133 [turnouts generally] and § 213.135 [switches].

*205(d) Each derail shall be properly installed for the rail to which it is applied. [This paragraph (d) is applicable September 21, 1999.]*

**Guidance:** Derails must be the proper size for the rail to which it is applied. Derails are manufactured to “sizes” based on the rail section to which they are to be applied and should be installed according to the manufacturer’s instructions. Installation of a derail of incorrect size can make a derail ineffective. Inspectors may use derail manufacturer instructions and specification as a guide to determine if a derail is properly installed (correct size for the rail to which it is applied).

Derails are made by “hand” (right or left) to derail equipment to a specific side of the track. In addition, “universal” derails will derail equipment in either direction. A derail that is installed to derail equipment toward a main track that should otherwise be protected would constitute an improperly installed derail. A “hand” derail placed in the wrong direction would also constitute an improperly installed derail.

## Subpart F – Inspection

### § 213.231 Scope

*This subpart prescribes requirements for the frequency and manner of inspecting track to detect deviations from the standards prescribed in this part.*

### § 213.233 Track inspections

*233(a) All track shall be inspected in accordance with the schedule prescribed in paragraph (c) of this section by a person designated under §213.7.*

**Guidance:** Recognizing that proper inspection of track is essential to safe maintenance, Subpart F contains the minimum requirements for the frequency and manner of inspecting track. Inspectors should know that a track owner may exceed the TSS in the interest of good practice, but they cannot be less restrictive. FRA's track safety program success is dependent upon the adequacy of the railroad's inspection efforts and subsequent maintenance program. Monitoring and assessing a railroad's track condition, through regular inspections, is integral to our safety success.

*233(b) Each inspection shall be made on foot or by riding over the track in a vehicle at a speed that allows the person making the inspection to visually inspect the track structure for compliance with this part. However, mechanical, electrical, and other track inspection devices may be used to supplement visual inspection. If a vehicle is used for visual inspection, the speed of the vehicle may not be more than 5 miles per hour when passing over track crossings and turnouts, otherwise, the inspection vehicle speed shall be at the sole discretion of the Inspector, based on track conditions and inspection requirements. When riding over the track in a vehicle, the inspection will be subject to the following conditions --*

- (1) One Inspector in a vehicle may inspect up to two tracks at one time provided that the Inspector's visibility remains unobstructed by any cause and that the second track is not centered more than 30 feet from the track upon which the Inspector is riding;*
- (2) Two Inspectors in one vehicle may inspect up to four tracks at a time provided that the Inspectors' visibility remains unobstructed by any cause and that each track being inspected is centered within 39 feet from the track upon which the Inspectors are riding;*
- (3) Each main track is actually traversed by the vehicle or inspected on foot at least once every two weeks, and each siding is actually traversed by the vehicle or inspected on foot at least once every month. On high density commuter railroad lines where track time does not permit an on track vehicle inspection, and where track centers are 15 foot or less, the requirements of this paragraph (b)(3) will not apply; and*
- (4) Track inspection records shall indicate which track(s) are traversed by the vehicle or inspected on foot as outlined in paragraph (b)(3) of this section.*

**Guidance:** This paragraph specifies the number of additional tracks that can be inspected. Depending upon whether one or two qualified railroad inspectors are in the vehicle, and depending upon the distance between adjacent tracks (30 or 39 feet, measured between track centerlines), a track owner's railroad inspectors may inspect multiple tracks (up to four) from hi-rail vehicles. Tracks obstructed from their view by tunnels, differences in ground level, railroad rolling stock, etc., cannot be included in the inspection record. Section 213.233(b)(3) requires each main track to be traversed at least once every 2

weeks, and a siding traversed at least once every month. Track inspection records, under § 213.241, must indicate which tracks are traversed in accordance with paragraph (b)(3).

233(c) *Each track inspection shall be made in accordance with the following schedule:*

<b>Class of Track</b>	<b>Type of Track</b>	<b>Required Frequency</b>
<i>Excepted track and Class 1, 2, and 3 track</i>	<i>Main track and sidings</i>	<i>Weekly with at least 3 calendar days interval between inspections, or before use, if the track is used less than once a week, or twice weekly with at least 1 calendar day interval between inspections, if the track carries passenger trains or more than 10 million gross tons of traffic during the preceding calendar year.</i>
<i>Excepted track and Class 1, 2, and 3 track</i>	<i>Other than main track and sidings</i>	<i>Monthly with at least 20 calendar days interval between inspections.</i>
<i>Class 4 and 5 track</i>	<i>.....</i>	<i>Twice weekly with at least 1 calendar day interval between inspections.</i>

**Guidance:** A geometry car inspection will not be considered acceptable for meeting the required inspection frequency specified by § 213.233(c), unless a waiver allowing this substitution is in effect.

Section 213.233(c) specifies the minimum frequency at which inspections must be conducted. For purposes under § 213.233(c) and outlined in the frequency schedule, “main track” is defined as “a track, other than an auxiliary track, extending through yards and between stations.” A siding is defined as “an auxiliary track for meeting or passing trains.” Section 213.233(c) also links inspection frequencies to the amount of annual tonnage, presence of passenger trains, and speed according to track class. A railroad’s change in the designation of a track to “other than main track” in its timetable and/or special instructions may not necessarily permit a railroad to reduce track inspection frequency. If the traffic remains essentially the same, the station designations remain, or if the method of operations continue the same, the track will be considered a main track with respect to the TSS. In addition, if any main track type operating rules or procedures are applicable to a track in question, FRA will consider such a track as a main track under the TSS. This would be the case even if the railroad uses the term such as spur, lead, running, etc. to describe the track in question. (Source: Letter dated July 10, 1991, from FRA Associate Administrator for Safety to Union Pacific Railroad.)

Each railroad inspection performed in accordance with the schedule prescribed in paragraph (c) must be made on foot or by riding over the track in a vehicle at a speed that allows the person making the inspections to visually inspect the track structure for compliance. An inspection made from a vehicle driven alongside the track does not constitute an inspection performed at the required frequency. The railroad may make additional inspections using other inspection methods provided that these inspections are not used to comply with frequency requirements prescribed in Section 213.233.

Inspecting after dark is in compliance with the requirements of § 213.233, Track inspections, as long as the railroad inspector is capable of detecting defects. As an example, inspections are routinely made in tunnels with limited or no lighting, and maintenance requirements may require inspections after daylight hours. Appropriate artificial lighting is required for an inspector to conduct a valid inspection.

When FRA inspectors are conducting inspections from a hi-rail vehicle, only the track occupied will be recorded on the F 6180.96 form [hi-rail main track (MTH) or hi-rail yard track (YTH)]. When conducting a walking inspection, multiple tracks may be inspected and counted as units on the F6180.96 form. It is recognized that walking inspections reveal more defective conditions than hi-rail inspections. Therefore, FRA inspectors may include multiple tracks while conducting walking inspections. Inspectors will use good judgment in ensuring a high-quality inspection while conducting walking inspections.

For the purposes of the application of inspection intervals, a week is defined as a period of 7 days, Sunday through Saturday. This is the accepted standard definition and emphasized here to avoid confusion when the railroad changes the starting and ending days of a week from inspector to inspector or from territory to territory. Classes 1 through 3 track require a weekly inspection with at least 3 calendar days interval between inspections, or before use, if the track is used less than once a week; or twice weekly with at least 1 calendar-day interval between inspections, if the track carries passenger trains, or more than 10 million gross tons of traffic, during the preceding calendar year.

When a railroad operates seasonal or irregular passenger service, it is expected that the twice weekly inspection will be conducted during those periods. A railroad will be considered to be in compliance if the twice weekly inspection occurs the week before and the week or weeks that the passenger trains are operated. If a one-time infrequent or seasonal passenger train movement occurs only on one day of a week, the twice weekly inspection the prior week and one\* inspection the week of the movement is adequate.

\*If the scheduled passenger train is to operate on one day only, at an interval during the week that does not allow for the two required inspections prior to that movement, then the one inspection for the week must occur before the movement.

*233(d) If the person making the inspection finds a deviation from the requirements of this part, the Inspector shall immediately initiate remedial action.*

*Note: to §213.233. Except as provided in paragraph (b) of this section, no part of this section will in any way be construed to limit the Inspector's discretion as it involves inspection speed and sight distance.*

**Guidance:** To ensure that railroads are providing proper inspections at the required frequency, inspectors must periodically examine the railroad's inspection records (noting record keeping type defects under § 213.241 only). By reviewing the track owner's inspection procedures and records, or through personal observations, inspectors will determine the number of tracks being inspected, the number of railroad inspectors performing inspections, the specific tracks inspected, and whether the railroad inspector actually traversed the track by vehicle or on foot. As specified in this section of the TSS, the track owner must assure all tracks are inspected in accordance with the prescribed schedule. Failure of the owner to comply with this schedule may constitute a violation.

If a track owner's qualified person, designated under § 213.7, finds a deviation from the TSS and fails to immediately initiate proper remedial action, the failure may constitute a violation. FRA track inspections do not constitute a required track inspection under the TSS. FRA inspections assess a railroad's compliance with Part 213. Inspectors will review a track owner's inspection records to learn if these records reflect the actual conditions of the track structure under train operations.

Turnouts and track crossings visually inspected from a vehicle must be accomplished at a speed not exceeding 5 mph. A vehicle's speed will be at the sole discretion of the operator and is based upon track conditions, inspection requirements, operating rules, and other circumstances that may vary from day to day and location to location. Nothing in the TSS precludes an inspection from a train or engine as long as the overall effectiveness of the inspection is not compromised and the person is able to visually inspect the track structure for compliance with this part. However, examining track while simultaneously operating a locomotive shall not be considered as an inspection under the TSS. The person must have the ability to stop movements to make a close examination of any possible track defect.

Deviations found under § 213.233 are those observed in the field as opposed to the § 213.241 recordkeeping requirements. Inspectors may also monitor other railroad records, such as a dispatcher's or control operator's record of track authorities conveyed and speed restrictions placed, to confirm that inspections were made and proper remedial actions were taken.

Classes 1 through 3 track require a weekly inspection with at least three calendar days interval between inspections, or before use, if the track is used less than once a week; or twice weekly with at least 1 calendar-day interval between inspections if the track carries passenger trains or more than 10 million gross tons of traffic during the preceding calendar year.

### **§ 213.234 Automated Inspection of Track Constructed with concrete Crossties**

**General Guidance:** This section —effective on July 1, 2012— requires the automated inspection of track constructed with concrete crossties. Automated inspection technology is available to perform essential tasks necessary to supplement visual inspection, quantify performance-based specifications to guarantee safe car behavior, and provide objective confidence and ensure safe train operations. Automated inspections also provide a level of safety superior to that of manual inspection methods by better analyzing overall weak points in track geometry and structural components. The computer systems in automated inspection systems can accurately detect geometry deviations from the Track Safety Standards and can analyze areas that are often hard to examine manually. Railroads benefit from automated inspection technology by having improved defect detection capabilities, suffering fewer track-related derailments, and improving overall track maintenance.

Automated inspection technology is used in Track Geometry Measurement Systems (TGMS), Gage Restraint Measurement Systems (GRMS), and Vehicle/Track Interaction (VTI) performance measurement systems. TGMS identifies single or multiple noncompliant track geometry conditions. GRMS aids in locating good or poor performing track strength locations. VTI performance measurement systems indicate both acceleration and wheel forces that, when exceeding established thresholds, often cause damage to track



components and rail equipment, as well as affect passenger ride quality. These automated systems can easily identify and measure track geometry, but they do not identify what causes them.

Automated technologies may be combined in the same or different geometry car platforms or vehicles, and require vehicle/track measurements to be made by truck frame accelerometers, car body accelerometers, or by instrumented wheel sets to measure wheel/rail forces, ensuring performance limits are not exceeded. Moreover, rail seat deterioration (RSD), can be very difficult and time consuming for inspectors to detect manually unless the rail and fastener assembly is removed. Automated inspection vehicles have proven effective in indicating RSD and can inspect much more rapidly and accurately than a visual track inspection. However, indications of RSD must be field-verified by inspectors taking accurate measurements to substantiate the recorded measurement system.

*234(a) General. Except for track described in paragraph (c) of this section, the provisions in this section are applicable on and after July 1, 2012. In addition to the track inspection required under § 213.233, for Class 3 main track constructed with concrete crossties over which regularly scheduled passenger service trains operate, and for Class 4 and 5 main track constructed with concrete crossties, automated inspection technology shall be used as indicated in paragraph (b) of this section, as a supplement to visual inspection, by Class I railroads (including Amtrak), Class II railroads, other intercity passenger railroads, and commuter railroads or small governmental jurisdictions that serve populations greater than 50,000. Automated inspection shall identify and report exceptions to conditions described in § 213.109(d)(4).*

**Guidance:** This paragraph specifies that automated inspection technology is to be used to supplement visual inspection by Class I railroads including Amtrak, Class II railroads, other intercity passenger railroads, and commuter railroads or small governmental jurisdictions that serve populations greater than 50,000, on track constructed of concrete crossties for Class 3 main track over which regularly scheduled passenger service trains operate, and for all Class 4 and 5 main track constructed with concrete crossties. Also, the rule requires that automated inspections identify and report concrete crosstie deterioration or abrasion prohibited by § 213.109(d)(4). The purpose of the automated inspection is to measure for RSD. As previously discussed, RSD is the failure of the concrete surface between the rail and crossties. § 213.109(d)(4) requires that the crosstie must not be “deteriorated or abraded at any point under the rail seat to a depth of ½ inch or more.” The depth includes the loss of rail pad material.

This paragraph explicitly states, that the requirements for automated track inspections do not become applicable until July 1, 2012.

Inspectors may use a step-gauge or caliper to verify the automated measurement of RSD and ensure proper rail seat depth compliance.

*234(b) Frequency of automated inspections. Automated inspections shall be conducted at the following frequencies:*

- (1) If annual tonnage on Class 4 and 5 main track and Class 3 main track with regularly scheduled passenger service, exceeds 40 million gross tons (mgt) annually, at least twice each calendar year, with no less than 160 days between inspections.*

- (2) *If annual tonnage on Class 4 and 5 main track and Class 3 main track with regularly scheduled passenger service is equal to or less than 40 mgt annually, at least once each calendar year.*
- (3) *On Class 3, 4, and 5 main track with exclusively passenger service, either an automated inspection or walking inspection must be conducted once per calendar year.*
- (4) *Track not inspected in accordance with paragraph (b)(1) or (b)(2) of this section because of train operation interruption shall be reinspected within 45 days of the resumption of train operations by a walking or automated inspection. If this inspection is conducted as a walking inspection, the next inspection shall be an automated inspection as prescribed in this paragraph.*

**Guidance:** Frequency of automated inspections states the frequencies at which track constructed of concrete crossties shall be inspected by automated means. An automated inspection must be conducted twice each calendar year, with no less than 160 days between inspections, if the annual tonnage on Class 4 and 5 main track and Class 3 main track with regularly scheduled passenger service exceeds 40 million gross tons. An automated inspection must be conducted at least once each calendar year if annual tonnage on Class 4 and 5 main track and Class 3 track with regularly scheduled passenger service equals or is less than 40 mgt annually.

Additionally, the regulation requires that either an automated or walking inspection be conducted once per calendar year on Class 3, 4 and 5 main track with exclusively passenger service. Track not inspected in accordance with paragraph (b)(1) or (b)(2) of this section because of train operation interruption must be reinspected within 45 days of the resumption of train operations by a walking or automated inspection. If this inspection is conducted as a walking inspection, the rule requires that the next scheduled inspection be an automated inspection. The rule provides sufficient flexibility to permit a track owner to schedule the inspections to allow for foreseeable operational conditions such as a standing train or failed equipment and still be able to conduct the required one or two inspections within a calendar year.

*234(c) Nonapplication. Sections of tangent track 600 feet or less constructed of concrete crossties, including, but not limited to, isolated track segments, experimental or test track segments, highway-rail crossings, and wayside detectors, are excluded from the requirements of this section.*

**Guidance:** NONAPPLICATION excludes from the required automated inspections sections of tangent track of 600 feet or less constructed of concrete crossties, including, but not limited to, isolated track segments, experimental or test track segments, highway-rail crossings, and wayside detectors. These exclusions are specified because FRA recognizes the economic burden caused by requiring automated inspections to be made on short isolated locations constructed of concrete crossties that may be difficult to measure without removal of additional material, such as grade crossing planking.

*234(d) Performance standard for automated inspection measurement system. The automated inspection measurement system must be capable of indicating and processing rail seat deterioration requirements that specify the following:*

- (1) *An accuracy, to within 1/8 of an inch;*

- (2) *A distance-based sampling interval, which shall not exceed five feet; and*
- (3) *Calibration procedures and parameters assigned to the system, which assure that indicated and recorded values accurately represent rail seat deterioration.*

**Guidance:** PERFORMANCE STANDARD FOR AUTOMATED INSPECTION MEASUREMENT SYSTEM requires that an automated inspection measurement system be capable of indicating and processing RSD requirements which specify the following: (1) an accuracy, to within 1/8 of an inch; (2) a distance-based sampling interval not exceeding five feet; and (3) calibration procedures and parameters assigned to the system, which assure that recorded values accurately represent RSD. RSD is indicated as a result of interpolations and calculations from rail cant measurements. The rail cant measurements provide an indication to the designated § 213.7 person that the location should be field-verified.

The design and practicality of all automated and autonomous geometry measurement systems is a supplement to visual inspection efforts toward identifying locations of greatest derailment risk. It is FRA's objective and policy that on-the-ground visual verification must be done by inspectors to validate not only RSD, but also all track structure and geometry conditions discovered by automated means. While other automated inspection technologies may exist, the belief is FRA's Rail Profile Measurement System (RPMS) is currently the best-developed technology to indicate (measure) RSD. The RPMS determines RSD by measuring rail cant angle in tenths of a degree. It is often difficult to measure rail cant in the field with hand measurement tools because of the small dimension, e.g., 1-degree rail cant angle equates to 1/8-inch depth between the rail seat and the rail. Typically the RPMS instrumentation onboard FRA geometry cars are set to notify an advisory 'alarm' exception when the angle exceeds 4 degrees of negative (outward) and positive (inward) rail cant.

FRA's current fleet of automated inspection systems provides a reliable method of determining RSD. However, to allow for future advances in technology, FRA does not mandate that a track owner's automated system 'measure' the rail cant angle to determine RSD. FRA also recognizes that detecting rail cant alone will not necessarily demonstrate all possible locations of RSD. For example, FRA geometry cars will not find areas of RSD that are due to compression forces from loads onto the crosstie. However, FRA geometry cars will locate RSD due to rail cant in curve and tangent track, which are the hardest areas to detect manually when the rail is obstructed.

*234(e) Exception reports to be produced by system; duty to field-verify exceptions. The automated inspection measurement system shall produce an exception report containing a systematic listing of all exceptions to § 213.109(d)(4), identified so that an appropriate person(s) designated as fully qualified under § 213.7 can field-verify each exception.*

- (1) *Exception reports must be provided to or be made available to all persons designated as fully qualified under § 213.7 and whose territories are subject to the requirements of § 213.234.*
- (2) *Each exception must be located and field verified no later than 48 hours after the automated inspection.*
- (3) *All field-verified exceptions are subject to all the requirements of this part.*
- (4) *Exception reports must note areas identified between 3/8 of an inch and 1/2 of an inch as an "alert."*

**Guidance:** EXCEPTION REPORTS TO BE PRODUCED BY SYSTEM; DUTY TO FIELD-VERIFY EXCEPTIONS requires that the automated inspection measurement system produce an exception report containing a systematic listing of all exceptions to § 213.109(d)(4), identified so that appropriate persons designated as fully qualified under § 213.7, either a supervisor under § 213.7(a) or a track inspector under § 213.7(b), can field-verify each exception. A designated qualified inspector must receive any noncompliant rail seat deterioration reports, whether the reports are made accessible to or are physically handed to the person designated under § 213.7, for field verification and repairs purposes. This paragraph also requires that each exception be located and field-verified no later than 48 hours after the automated inspection, and that all field-verified exceptions are subject to all the requirements of Part 213. Inspectors should ensure that exceptions between three-eighths of an inch and one-half of an inch are reported as an ‘alert.’ Automated inspection exceptions equal to or greater than one-half inch would require field-verification by a qualified person under § 213.7. This is not only to ensure that the exception report accurately reflects the conditions of the track, but also to ensure that a qualified person can take appropriate remedial action in a timely manner.

*234(f) Recordkeeping requirements. The track owner shall maintain and make available to FRA a record of the inspection data and the exception record for the track inspected in accordance with this paragraph for a minimum of two years. The exception reports must include the following:*

- (1) Date and location of limits of the inspection;*
- (2) Type and location of each exception;*
- (3) Results of field verification; and*
- (4) Remedial action if required.*

**Guidance:** RECORDKEEPING REQUIREMENTS contains a requirement that the track owner maintain a record of the inspection data and the exception record for the track inspected in accordance with this section for a minimum of 2 years. The record must include the date and location of limits for the inspection, type and location of each exception, the results of field verification, and any remedial action if required. The location identification must be provided either by milepost or by some other objective means, such as by the location description provided by the Global Positioning System. This new regulation is intended to require the track owner to keep a good record of the conditions of track constructed of concrete crossties and, through such records, FRA track inspectors will have a greater ability to gain access to and accurately assess the railroad’s compliance history.

*234(g) Procedures for integrity of data. The track owner shall institute the necessary procedures for maintaining the integrity of the data collected by the measurement system. At a minimum, the track owner shall do the following:*

- (1) Maintain and make available to FRA documented calibration procedures of the measurement system that at a minimum, specify an instrument verification procedure that ensures correlation between measurements made on the ground and those recorded by the instrumentation; and*
- (2) Maintain each instrument used for determining compliance with this section such that it accurately provides an indication of the depth of rail seat deterioration in accordance with*

*paragraph (d)(1) of this section.*

**Guidance:** PROCEDURES FOR INTEGRITY OF DATA requires that the track owner institute the necessary procedures for maintaining the integrity of the data collected by the measurement system. The track owner must maintain and make available to FRA documented calibration procedures of the measurement system that, at a minimum, specifies an instrument verification procedure that will ensure correlation between measurements made on the ground and those recorded by the instrumentation. Also, the track owner must maintain each instrument used for determining compliance with this section. The purpose of this paragraph is to ensure that the equipment that the track owner is using to comply with the regulations accurately detects what it is designed to detect. In lieu of rail cant angle reference, track owners can use alternative means of technology in their automated inspections to indicate RSD.

*234(h) Training. The track owner shall provide annual training in handling rail seat deterioration exceptions to all persons designated as fully qualified under § 213.7 and whose territories are subject to the requirements of § 213.234. At a minimum, the training shall address the following:*

- (1) Interpretation and handling of the exception reports generated by the automated inspection measurement system;*
- (2) Locating and verifying exceptions in the field and required remedial action; and*
- (3) Recordkeeping requirements.*

**Guidance:** TRAINING requires that the track owner provide annual training in handling RSD exceptions to all persons designated as fully qualified under § 213.7 and whose territories are subject to the requirements of § 213.234. At a minimum, the annual training required by this paragraph shall address interpretation and handling of the exception reports generated by the automated inspection measurement system, locating and verifying exceptions in the field and required remedial action, and recordkeeping requirements. The objective is to ensure that all persons required to comply with the regulations are properly trained.

### **§ 213.235 Inspection of switches, track crossings, and lift rail assemblies or other transition devices on moveable bridges**

*235(a) Except as provided in paragraph (c) of this section, each switch, turnout, track crossing, and moveable bridge lift rail assembly of other transition device shall be inspected on foot at least monthly.*

**Guidance:** Paragraph (a) prescribes the frequency and method of inspection for switches, turnouts, track crossings, and moveable bridge lift rail assemblies or other transition devices by a track owner's qualified persons. By examining records and conducting field investigations, FRA inspectors can confirm the track owner's on foot inspection of each switch, turnout, track crossing, and moveable lift bridge rail assembly at least monthly.

*235(b) Each switch in Classes 3 through 5 track that is held in position only by the operating mechanism and one connecting rod shall be operated to all of its positions during one inspection in every three month period.*

**Guidance:** Each switch, in Classes 3 through 5 track, which is held in normal or reverse position by only one connecting rod is required to be operated (thrown) in all its positions during one track inspection by the track owner in every 3-month period. An example of a switch that has more than one connecting rod is a switch that also has a lock rod. A rod connecting a switch to a switch circuit controller (point detector) is not considered to be a rod that holds a switch in position. This requirement is designed to emphasize the importance of these nonredundant mechanisms. Thorough inspection is best accomplished by operating the switch mechanism to allow for a comprehensive inspection of these components. Inspectors should observe the various switch components, determine their functional design, and assess missing components that are integral to safe operation. If the proper operation of the points is in doubt, inspectors should use the appropriate codes under § 213.133. The phrase “all positions” is intended to cover slip and lap (three-way) switches.

*235(c) In the case of track that is used less than once a month, each switch, turnout, track crossing, and moveable bridge lift rail assembly or other transition device shall be inspected on foot before it is used.*

**Guidance:** “Lift rails” have unique properties and functions. This discussion will focus on cast manganese alloy types of lift rail assemblies that provide a transition between a fixed span and a movable span on lift bridges, swing bridges, and bascules. Lift rails are made of three pieces for swing bridges: a section on the fixed span, a section on the movable span, and the rocker.

Analogous to a rail in some respects, a manganese lift rail provides a running surface and it is also similar to a rail joint in that it joins rails at the ends of bridge spans. It is made of manganese alloy, and it has the appearance of a frog.

Manganese lift rails have tapered sections to reduce shock. The design provides for the transfer of wheels to take place on one span, rather than between spans. Track and bridge maintenance personnel familiar with manganese steel lift rails point out that cracks generally progress slowly.

Railroad maintenance officials advocate proper maintenance to prevent or reduce cracking of manganese lift rails. Because there is deformation of manganese over time, they recommend that metal flow be ground at the wheel contact point to reduce or prevent cracks. Railroad maintenance personnel also emphasize that the bridge itself can aggravate wear and deterioration of manganese steel lift rails when the bridge needs to be adjusted or repaired. The condition of the bridge ties, for example, is an important factor in the maintenance of these of such assemblies.



Policies regarding speeds on manganese lift rails are set by each railroad. Some railroads require a 25 mph maximum speed on all lift rails regardless of condition. Further reductions of train speeds should be placed when the lift rails deteriorate to prohibitive levels. In deciding to place a speed restriction or remove a lift rail from service, railroads consider a wide range of factors including the amount of traffic, bridge condition, and the condition of the lift rail itself.

In summary:

- When evaluating the safety of a manganese lift rail assembly, inspectors must consider that cracks in manganese casting are known to propagate slowly. Although cracks are known to propagate slowly, they can be more hazardous under certain bridge conditions, such as a deteriorated deck. Inspectors are cautioned against citing § 213.113 (Defective rails) to describe cracks in the manganese casting running surface of the manganese lift rail appliance.
- Specific concerns about the safety of a manganese steel lift rails must be immediately brought to the attention of an appropriate railroad manager and discussed with the regional track specialist.

**General Guidance:** Inspections conducted from a vehicle are not considered sufficient to determine compliance. Therefore, each switch; turnout; track crossing; and lift rail assembly, or other transition device on moveable bridges, will be inspected by a walking inspection before FRA inspectors can consider a unit (activity) inspected, as outlined in Chapter 2 of this manual.

### § 213.237 Inspection of rail

*237(a) In addition to the inspections required by § 213.233, each track owner shall conduct internal rail inspections sufficient to maintain service failure rates per rail inspection segment in accordance with this paragraph (a) for a 12-month period, as determined by the track owner and calculated within 45 days of the end of the period. These rates shall not include service failures that occur in rail that has been replaced through rail relay since the time of the service failure. Rail used to repair a service failure defect is not considered relayed rail. The service failure rates shall not exceed—*

- (1) 0.1 service failure per year per mile of track for all Class 4 and 5 track;*
- (2) 0.09 service failure per year per mile of track for all Class 3, 4, and 5 track that carries regularly-scheduled passenger trains or is a hazardous materials route; and*
- (3) 0.08 service failure per year per mile of track for all Class 3, 4, and 5 track that carries regularly-scheduled passenger trains and is a hazardous materials route.*

**Guidance:** The changes to this section codify standard industry good practices. With the implementation of the self-adaptive performance-based rail inspection scheduling method in the 1990s, track owners have generally tested more frequently than they have been required to, and the test intervals align more closely with generally accepted maintenance practices. The frequency of rail inspection cycles varies according to the total detected defect rate per test; the rate of service failures, as defined in paragraph (j) below, between tests; and the accumulated tonnage between tests—all of which are factors that the railroad industry's rail quality managers generally consider when determining inspection schedules.

Paragraph (a) requires track owners to maintain service failure rates of no more than 0.1 per year per mile of track for all Classes 4 and 5 track; no more than 0.09 per year per mile of track for all Classes 3, 4, and 5 track that carries regularly scheduled passenger trains or is a hazardous materials route; and no more than 0.08 per year per mile of track for all Classes 3, 4, and 5 track that carries regularly-scheduled passenger trains and is a hazardous materials route.

The required inspection frequency can be verified by using the FRA Self-Adaptive Scheduling Algorithm. This performance-based method will normally require an increase in the inspection frequency when the railroad exceeds the service failure rate. For track owners without access to a sophisticated, self-scheduling algorithm to determine testing frequencies, FRA posted an algorithm program designed by the Volpe National Transportation Systems Center (Volpe) on the FRA Web site at [www.fra.dot.gov](http://www.fra.dot.gov). The algorithm requires five inputs:

1. Service failures per mile in the previous year
2. Detected defects per mile in the previous year
3. Annual tonnage
4. Number of rail tests conducted in the previous year; and
5. Targeted number of service failures per mile

Once the input is complete, the algorithm takes the average of two numbers when it calculates the number of rail tests. The first number is based on the service failure rate. The second is based on the total defect rate, which is the service defect rate plus the detected defect rate. This rate of designated tests per year for the designated segment is the number of required tests per year enforced by FRA for the segment.

The output from the program is the annual number of rail tests that should be conducted over the segment in order to maintain an acceptable or tolerable level of risk. In this context, risk is the number of service failures per mile in a segment of track for a 1-year period. The designated 1-year period may be a calendar year or fiscal year, depending on the normal internal engineering practice of the railroad.

*237(b) Each rail inspection segment shall be designated by the track owner no later than March 25, 2014, for track that is Class 4 or 5 track, or Class 3 track that carries regularly-scheduled passenger trains or is a hazardous materials route and is used to determine the milepost limits for the individual rail inspection frequency.*

*(1) To change the designation of a rail inspection segment or to establish a new segment pursuant to this section, a track owner must submit a detailed request to the FRA Associate Administrator for Railroad Safety/Chief Safety Officer (Associate Administrator). Within 30 days of receipt of the submission, FRA will review the request. FRA will approve, disapprove, or conditionally approve the submitted request, and will provide written notice of its determination.*

*(2) The track owner's existing designation shall remain in effect until the track owner's new designation is approved or conditionally approved by FRA.*

*(3) The track owner shall, upon receipt of FRA's approval or conditional approval, establish the designation's effective date. The track owner shall advise in writing FRA and all affected railroad employees of the effective date.*

**Guidance:** No uniform segment length is required to be applied by all track owners. Track owners use their own designated segment lengths in place by the effective date of this final rule, March 25, 2014, and the designated segments have been reported to FRA. It is not considered practical for a railroad to utilize segments that are too small. The level of detail involved with determining inspection frequencies on so many individual segments would be too burdensome for the track engineers to manage properly. It is also not advisable to have



segments that are too large because localized areas of defect development and rail failure may go unrecognized. Therefore, it is advisable that the railroads utilize reasonable lengths for their designated segment. Most railroads have identified and currently utilize a designated segment in their engineering plans. Some segments are designated by mileage and track limits and others by subdivision limits. FRA Inspectors should be able to capture rail failure data and identify problematic areas, even in the larger segment areas, by simply looking at rail failure records and comparing milepost locations.

Although, each rail inspection segment is designated by the track owner, if a track owner wishes to change, or deviate, from its designated segment lengths, the track owner must receive FRA approval to make any such change. To change the designation of a rail inspection segment or to establish a new segment pursuant to this section, a track owner must submit a detailed request to the FRA Associate Administrator for Railroad Safety/Chief Safety Officer (Associate Administrator). Within 30 days of receipt of the submission, FRA will review the request. FRA will then approve, disapprove, or conditionally approve the submitted request, and will provide written notice of its determination.

*213(c) Internal rail inspections on Class 4 and 5 track, or Class 3 track with regularly-scheduled passenger trains or that is a hazardous materials route, shall not exceed a time interval of 370 days between inspections or a tonnage interval of 30 million gross tons (mgt) between inspections, whichever is shorter. Internal rail inspections on Class 3 track that is without regularly-scheduled passenger trains and not a hazardous materials route must be inspected at least once each calendar year, with no more than 18 months between inspections, or at least once every 30 mgt, whichever interval is longer, but in no case may inspections be more than 5 years apart.*

*(1) Any rail used as a replacement plug rail in track that is required to be tested in accordance with this section must have been tested for internal rail flaws.*

*(2) The track owner must verify that any plug rail installed after March 25, 2014, has not accumulated more than a total of 30 mgt in previous and new locations since its last internal rail flaw test, before the next test on the rail required by this section is performed.*

*(3) If plug rail not in compliance with this paragraph (c) is in use after March 25, 2014, trains over that rail must not exceed Class 2 speeds until the rail is tested in accordance with this section.*

**Guidance:** FRA requires that internal rail inspections on Classes 4 and 5 track, or Class 3 track with regularly scheduled passenger trains or that is a hazardous materials route, not exceed a time interval of 370 days between inspections or a tonnage interval of 30 mgt between inspections, whichever is shorter. Paragraph (c) also provides that internal rail inspections on Class 3 track that is without regularly scheduled passenger trains and not a hazardous materials route must be inspected at least once each calendar year, with no more than 18 months between inspections, or at least once every 30 mgt, whichever interval is longer, but in no case may inspections be more than 5 years apart.

Note that the maximum tonnage interval for testing internal rail defects on Classes 4 and 5 track, and certain Class 3 track, has decreased from 40 mgt in former paragraph (a) of this section to 30 mgt.

This section also includes additional requirements for inspection of rail intended for reuse, or “plug rail.” Plug rail must be inspected at the same frequency as conventional rail. This requirement supersedes FRA Safety Advisory 2006-02 and codifies current industry

practice by allowing the use of rail that has been previously tested to be placed in track and retested at the normal frequency for that track segment. The track owner should know the date that the rail was last tested and ensure that the 30 mgt maximum tonnage accumulation is not exceeded prior to retesting the rail. As stated in (c)(2), the track owner is required to be able to verify that any plug installed after the effective date of this final rule, March 25, 2014, has not accumulated more than a total of 30 mgt in previous and new locations since its last internal rail flaw test, before the next test on the rail required by this section is performed. Thereafter, the rail must be tested in accordance with the test frequency of the designated segment in which it is installed. Re-inspection of plug rails installed prior to this rule is not required.

The inspection frequency requirements stated in this paragraph consider both the passage of time and the accumulated tonnage since the last inspection. Several methods are employed by railroads to estimate tonnage, but they are only estimates and cannot be considered as precisely accurate. In addition, scheduling of rail detection cars is influenced by many factors such as the availability of equipment if the service is contracted, equipment failures, or various other scheduling problems that may arise.

For Class 3 track, over which only non-hazmat freight operations are conducted, the date of the most recent inspection will define the beginning of a new inspection cycle, and before the expiration of time or tonnage limits, whichever is longer, an inspection for internal rail defects must be conducted. For Classes 4 and 5 track, and Class 3 track over which passenger trains or hazmat trains operate, the date of the most recent inspection will define the beginning of a new inspection cycle, and before the expiration of time or tonnage limits, whichever is shorter, an inspection for internal rail defects must be conducted.

Language in § 213.237(a) refers to § 213.233 (Track inspections) indicating that many rail defects, as well as conditions caused by wear or damage, cannot be visually discovered. These require an internal search by a detector car or other specialized detection equipment.

Some railroads elected to perform more internal rail inspections than required under the TSS, with intervals between tests typically ranging from 20 to 30 million gross tons or between 20 and 30 days. These typical intervals define a good baseline for generally accepted maintenance practices, and the industry's rail quality managers consider these limits as points of departure for adjustment of test schedules to account for the effects of specific track characteristics, maintenance, traffic, and weather.

Selecting an appropriate frequency of rail testing is a complex task involving many different factors which include, but are not limited to, temperature differential, curvature, residual stresses, rail sections, cumulative tonnage, and past rail test results. Taking into consideration all of the above factors, FRA's research suggests that 30 million gross tons is the maximum tonnage that should be hauled between rail tests and still allow a safe window of opportunity for detection of an internal rail flaw before it propagates in size to a service failure. Furthermore, FRA's accident/incident data points to a need for inclusion of all Class 3 trackage in a railroad's rail testing program. The requirement states that Class 3 track, over which passenger or hazmat trains do not operate, should be tested once a year or once every 30 million gross tons, whichever is longer.

*237 (d) If the service failure rate target identified in paragraph (a) of this section is not achieved, the track owner must inform FRA of this fact within 45 days of the end of the defined 12-month period in which the performance target is exceeded. In addition, the track owner may*

*provide to FRA an explanation as to why the performance target was not achieved and provide a remedial action plan.*

*(1) If the performance target rate is not met for two consecutive years, then for the area where the greatest number of service failures is occurring, either:*

- (i) The inspection tonnage interval between tests must be reduced to 10 mgt; or*
- (ii) The class of track must be reduced to Class 2 until the target service failure rate is achieved.*

*(2) In cases where a single service failure would cause the rate to exceed the applicable service failure rate as designated in paragraph (a) of this section, the service failure rate will be considered to comply with paragraph (a) of this section unless a second such failure occurs within a designated 12-month period. For the purposes of this paragraph (d)(2), a period begins no earlier than January 24, 2014.*

**Guidance:** Paragraph (d) contains restrictions that apply if the service failure target rate identified in paragraph (a) is not achieved on a segment of track for two consecutive 12-month periods. After the first 12-month period is exceeded, it is expected that the railroad will increase rail inspections to decrease the service failure rate. If the service failure target rate is exceeded for two consecutive 12-month periods, the track owner must comply with the requirements in paragraph (d) for either a minimum rail test frequency or a speed restriction on the offending track segment. Rail integrity or designated specialists will review service failure data on a regular basis and seek to identify any instances where shorter lengths of track have high failure rates.

*237(e) Each defective rail shall be marked with a highly visible marking on both sides of the web and base except that, where a side or sides of the web and base are inaccessible because of permanent features, the highly visible marking may be placed on or next to the head of the rail.*

**Guidance:** Paragraph (e) requires that each defective rail be marked with a highly visible marking on both sides of the web and base except that, where a side or sides of the web and base are inaccessible because of permanent features, the highly visible marking may be placed on or next to the head of the rail. This option to mark the rail head in certain situations provides an alternative to the railroad in areas where the web and base may not be accessible.

Each defective rail must be marked on both sides of the web and base to prevent reuse of the rail. A defect's identity and control numbers are not required on the web and base, but may be used by a railroad for inventory purposes. Inspectors should be aware that rail with certain defects, such as a bolt hole crack, may have the defective portion "cropped" and the remaining portion placed back in service. The track owner may remove defect markings from the nondefective portion of such rail.

*237(f) Inspection equipment shall be capable of detecting defects between joint bars, in the area enclosed by joint bars.*

**Guidance:** The equipment used must be capable of detecting defects in the joint area and the body of the rail. Two separate systems may be used to meet this requirement, provided that each is used before the expiration of the time or tonnage limits as required by this section.

*237(g) If the person assigned to operate the rail defect detection equipment (i.e., the qualified operator) determines that a valid search for internal defects could not be made over a particular length of track, that particular length of track may not be considered as internally inspected under paragraphs (a) and (c) of this section.*

**Guidance:** Paragraph (g) addresses a situation where a valid search for internal rail defects cannot be made because of rail surface conditions, equipment issues, or other factors. Several types of technologies are presently employed to continuously search for internal rail defects, some with varying means of displaying and monitoring search signals. A continuous search is intended to mean an uninterrupted search by whatever technology is being used, so that there are no segments of rail that are not tested. If the test is interrupted (e.g., as a result of rail surface conditions that inhibit the transmission or return of the signal), then the test over that segment of rail is not valid because it was not continuous. Therefore, a non-test is not defined in absolute technical terms. Rather, the provision leaves this determination to the qualified operator, as defined in § 213.238, who is uniquely qualified on that equipment.

*237(h) If a valid search for internal defects could not be conducted, the track owner shall, before expiration of the time or tonnage limits in paragraph (a) or (c) of this section—*

- (1) Conduct a valid search for internal defects;*
- (2) Reduce operating speed to a maximum of 25 m.p.h. until such time as a valid search can be made; or*
- (3) Replace the rail that had not been inspected.*

**Guidance:** This paragraph specifies the three options available to a railroad following a non-test due to rail surface conditions. These options must be exercised prior to the expiration of time or tonnage limits specified in the paragraph (a) or (c) of this section. If doubts exist concerning a defective rail's disposition, inspectors should review the track owner's records, under § 213.241(c). When conducting a records inspection, inspectors will determine whether the requirements of § 213.113(a)(2) and § 213.237 (h) are in compliance and whether valid inspections have occurred. The expiration of time and tonnage limits must be determined before any compliance action is taken.

Broken rails continue to be one of the leading causes of train accidents. Inspectors should examine records to ensure railroad internal rail inspection frequency compliance, and should be alert during track inspections to any rail that is marked as defective. During accident investigations where a broken rail is a factor, inspectors should provide complete information on type of defects, results of last rail inspection, type of inspection equipment used, track usage since last inspection, and accumulated tonnage on that rail. See the guidance under § 213.237(g) for a discussion of the situation where a valid search for internal rail defects could not be made because of rail surface conditions.

*237(i) The person assigned to operate the rail defect detection equipment must be a qualified operator as defined in § 213.238 and have demonstrated proficiency in the rail flaw detection process for each type of equipment the operator is assigned.*

**Guidance:** The rail flaw detector car operator must be qualified as defined in new § 213.238 (Qualified operator), which prescribes minimum training, evaluation, and documentation requirements for personnel performing in this occupation.

*237(j) As used in this section—*

(1) *Hazardous materials route means track over which a minimum of 10,000 car loads or intermodal portable tank car loads of hazardous materials as defined in 49 CFR 171.8 travel over a period of one calendar year; or track over which a minimum of 4,000 car loads or intermodal portable tank car loads of the hazardous materials specified in 49 CFR 172.820 travel, in a period of one calendar year.*

(2) *Plug rail means a length of rail that has been removed from one track location and stored for future use as a replacement rail at another location.*

(3) *Service failure means a broken rail occurrence, the cause of which is determined to be a compound fissure, transverse fissure, detail fracture, or vertical split head.*

(4) *Valid search means a continuous inspection for internal rail defects where the equipment performs as intended and equipment responses are interpreted by a qualified operator as defined in § 213.238.*

### **§ 213.238 Qualified operator.**

*238(a) Each provider of rail flaw detection shall have a documented training program in place and shall identify the types of rail flaw detection equipment for which each equipment operator it employs has received training and is qualified. A provider of rail flaw detection may be the track owner. A track owner shall not utilize a provider of rail flaw detection that fails to comply with the requirements of this paragraph.*

**Guidance:** Any provider of rail flaw detection must have a documented training program to ensure that a rail flaw detection equipment operator is qualified to operate each of the various types of equipment currently used in the industry for which he or she is assigned, and that proper training is provided when new rail flaw detection technologies are used.

It is the responsibility of the track owner to reasonably ensure that any operator of rail flaw detection equipment over its track is qualified to conduct an inspection in accordance with the training and qualification requirements in this section, because the track owner is ultimately responsible for the conformance of its track and rail with the requirements of the Track Safety Standards.

*238(b) A qualified operator shall be trained and have written authorization from his or her employer to:*

(1) *Conduct a valid search for internal rail defects utilizing the specific type(s) of equipment for which he or she is authorized and qualified to operate;*

(2) *Determine that such equipment is performing as intended;*

(3) *Interpret equipment responses and institute appropriate action in accordance with the employer's procedures and instructions; and*

(4) *Determine that each valid search for an internal rail defect is continuous throughout the area inspected and has not been compromised due to environmental contamination, rail conditions, or equipment malfunction.*

**Guidance:** Each operator of rail flaw detection equipment must have documentation from his or her employer that designates his or her qualifications to perform the various functions associated with the flaw detection process. Specifically, the requirements help ensure that each operator is able to conduct a valid search for internal rail flaws, determine that the equipment is functioning properly at all times, properly interpret the test results, and understand test equipment limitations.

*238(c) To be qualified, the operator must have received training in accordance with the documented training program and a minimum of 160 hours of rail flaw detection experience under direct supervision of a qualified operator or rail flaw detection equipment manufacturer's representative, or some combination of both. The operator must demonstrate proficiency in the rail defect detection process, including the equipment to be utilized, prior to initial qualification and authorization by the employer for each type of equipment.*

**Guidance:** The operator must receive a minimum amount of documented, supervised training according to the rail flaw detection equipment provider's training program. FRA understands that this training may not be entirely held within the classroom environment and is in agreement that the employer should have the flexibility to determine the training process that is appropriate for demonstrating compliance. The operator is required to demonstrate proficiency for each type of equipment the employer intends the operator to use, and documentation must be available to FRA to verify the qualification.

*238(d) Each employer shall reevaluate the qualifications of, and administer any necessary recurrent training for, the operator as determined by and in accordance with the employer's documented program. The reevaluation process shall require that the employee successfully complete a recorded examination and demonstrate proficiency to the employer on the specific equipment type(s) to be operated. Proficiency may be determined by a periodic review of test data submitted by the operator.*

**Guidance:** Operator reevaluation and, as necessary, refresher training is required in accordance with the documented training program. The employer is provided flexibility to determine the process used in reevaluating qualified operators, including the frequency of operator reevaluation. The reevaluation process shall require that the employee successfully complete a recorded examination and demonstrate proficiency to the employer on the specific equipment types to be operated. The reevaluation and recurrent training may also consist of a periodic review of test data submitted by the operator.

*238(e) Each employer of a qualified operator shall maintain written or electronic records of each qualification in effect. Each record shall include the name of the employee, the equipment to which the qualification applies, date of qualification, and date of the most recent reevaluation, if any.*

**Guidance:** The employer must maintain a written or electronic record of each operator's qualification. The record must include the operator's name, type of equipment qualification, date of initial qualification, and most recent reevaluation of his or her qualifications, if any.

*238(f) Any employee who has demonstrated proficiency in the operation of rail flaw detection equipment prior to January 24, 2014, is deemed a qualified operator, regardless of the previous training program under which the employee was qualified. Such an operator shall be subject to paragraph (d) of this section.*

**Guidance:** All rail flaw detection equipment operators who have demonstrated proficiency in the operation of rail flaw detection equipment prior to publication of this final rule, , January 24, 2014, are considered qualified to operate the equipment as designated by the employer. Such an operator must thereafter undergo reevaluation in accordance with paragraph (d) of this section. Any employee that is considered for the position of qualified operator on or after the final rule's publication must be qualified in accordance with paragraph (c) of this section.

*238 (g) Records concerning the qualification of operators, including copies of equipment - specific training programs and materials, recorded examinations, demonstrated proficiency*

*records, and authorization records, shall be kept at a location designated by the employer and available for inspection and copying by FRA during regular business hours.*

**Guidance:** Records specifically associated with the operator qualification process must be maintained at a designated location and made available to FRA as requested, to assist in verifying compliance.

### **§ 213.239 Special inspections**

*In the event of fire, flood, severe storm, or other occurrence which might have damaged track structure, a special inspection shall be made of the track involved as soon as possible after the occurrence and, if possible, before the operation of any train over that track.*

**Guidance:** This section is general in nature, because it is not practical to specify all the conditions that could trigger a special inspection or the specific manner and timing. This section is not meant to imply that train operations must necessarily stop until the special inspection is made. However, all special inspections should be conducted for the primary purpose of determining whether the track structure is safe for the continued operation of trains. Inspectors are directed to review the significant impacts to railroad operations in regard to storms as discussed in any applicable safety advisory.

Because a number of train derailments have been caused by unexpected track damage from moving water in the past, FRA deemed it appropriate to issue Safety Advisory 97-1, which recommends procedures that reflect effective industry practices for special track inspections. The procedures consist of:

1. Prompt notification to dispatchers of expected bad weather.
2. Limits on train speed on all track subject to flood damage, following the issuance of a flash flood warning, until a special inspection can be performed.
3. Identification of bridges carrying Class 4 or higher track that are vulnerable to flooding and over which passenger trains operate.
4. Availability of information about each bridge, such as identifying marks, for those who may be called to perform a special inspection.
5. Training programs and refresher training for those who perform special inspections.
6. Availability of a bridge maintenance or engineering employee to evaluate the railroad track inspector's findings.

Although the advisory contains a sample list of sudden events that routinely occur in nature, this provision is not limited to only the occurrences listed or to only natural disasters. Section 213.239 addresses the need to inspect after "other occurrences," which include such natural phenomena as temperature extremes, as well as unexpected events that are human-caused (e.g., a vehicle that falls on the tracks from an overhead bridge, a water main break that floods a track roadbed, or terrorist activity that damages track). This interpretation is not new; FRA has always viewed this section to encompass sudden events of all kinds that affect the safety and integrity of track.

Inspectors should determine the procedures that have been established by the railroad to comply with § 213.239, mindful that advisory procedures are not mandatory. Procedures should include the method employed by the railroad to receive information on severe weather (e.g., who receives the information and what is done with that information). When the railroad is notified of a possible track-damaging occurrence, a special inspection must be made. A track owner may designate any official to be responsible for making a determination on whether a special inspection, under § 213.239, is required. The designation is not limited to any certain craft, but the official must be trained and qualified to assure a proper inspection was conducted. The TSS do not require railroads to keep written records of special inspections, and so FRA inspectors will not have any such records to determine railroad compliance with this section. As a result, FRA inspectors should look to other sources (e.g., train dispatcher hi-rail occupancy records) to determine compliance.

### **§ 213.241 Inspection records**

*241(a) Each owner of track to which this part applies shall keep a record of each inspection required to be performed on that track under this subpart.*

**Guidance:** Each track owner is required to keep a record of each track inspection according to the requirements under §§ 213.4, 213.119, 213.233, and 213.235. Each inspection report under these sections must be prepared on the day of inspection and signed by the person making the inspection.

The track owner may develop any form that meets the requirements of the TSS. If the owner finds it necessary to conduct requires inspections at more frequent intervals than specified by § 213.233(c), then the only requirement is to prepare and maintain an inspection record to comply with the minimum inspection frequency. This section is explicit concerning the required information contained in the inspection records. They must specify the track inspected [including the provisions under § 213.233(b)(3)], date of inspection, location and nature of any defect, and the remedial action taken by the person making the inspection. Railroad inspection reports are required to reflect the actual conditions, as they exist in the track structure. The railroad inspector must include the specific measurement of the track parameter, whenever appropriate, when describing the nature of the defect per § 213.241(b). For example: “wide gage exceeds allowable for Class 4 track - 58 inches - track slow ordered to 10 m.p.h.” When defects are discovered, the track owner’s inspectors and immediately initiate remedial action, in accordance with § 213.5. If a speed restriction is used as remedial action, the reduced speed should be shown in the inspection records.

Railroad track inspectors are required to list all deviations from the TSS on their inspection record. FRA inspectors should review railroad inspection records to determine if the reported data accurately reflects the track conditions, as they exist in the field. Railroad inspectors are not limited to recording deviations from the TSS (e.g., railroad maintenance items). FRA inspectors should compare the defects they find with the railroad inspectors’ reports to determine the level of compliance with the railroad’s inspection program. If multiple tracks are being inspected, the records must designate the tracks traversed and any tracks not inspected due to visibility obstruction or excessive distance as required under § 213.233.

When two qualified persons inspect multiple tracks in accordance with § 213.233(b), one report or two reports may be optionally prepared. If one report is used, the report must include a notation such as signature, initials, or printed name of the second inspector.



Rail inspection records must be maintained by the track owner for at least 2 years after the inspection and for 1 year after the last remedial action is taken. The record must specify the location and nature of any rail defects found through internal inspection, and the remedial action taken and the date thereof. This record may consist of log sheets combined with a standard rail defect and change out report, computer records, or other data kept by the track owner and containing all the required information.

The rail inspection records must specify the locations of any rail that, due to rail surface conditions, prohibit the railroad from conducting a valid search for internal defects at the required frequency. If a valid search cannot be conducted before the time or tonnage frequency expires, the remedial action and date of remedial action must be recorded on the inspection records.

*241(b) Each record of an inspection under §§ 213.4, 213.119, 213.233, 213.234, and 213.235 shall be prepared on the day the inspection is made and signed by the person making the inspection. Records shall specify the track inspected, date of inspection, location and nature of any deviation from the requirements of this part, and the remedial action taken by the person making the inspection. The owner shall designate the location(s) where each original record shall be maintained for at least one year after the inspection covered by the record. The owner shall also designate one location, within 100 miles of each state in which they conduct operations, where copies of record which apply to those operations are either maintained or can be viewed following 10 days notice by the Federal Railroad Administration.*

**Guidance:** FRA added § 213.119 to the list of sections in paragraph (b), thereby requiring that inspections of joints made pursuant to § 213.119 comply with the inspection record requirements found in § 213.241(b). The paragraph identifies the new rule § 213.234 as a recordkeeping requirement.

In reviewing compliance with this section, inspectors should determine if the track owner is properly recording the location and date when each switch that is held in position only by the operating mechanism and a connecting rod are operated in every 3-month period (§ 213.235(c)). In addition, the record should reflect when each siding was actually traversed by a vehicle or on foot at the required frequency (§ 213.233(c)).

The regulation allows railroads to designate a location within 100 miles of each state (designated locations) where inspectors can view records. Inspectors are required to give 10 days advance notice before conducting the record keeping inspection of designated locations. The regulation does not require the railroads to maintain the records at these designated locations, only to be able to provide viewing of them at the locations within 10 days after notification. The TSS stipulates locations within 100 miles of each State, rather than locations in each State, to accommodate those railroads whose operations may cross a State's line by only a few miles. In those cases, the railroad could designate a location in a neighboring State, provided the location is within 100 miles of that State's border. Records must be kept for at least 1 year after the inspection covered by the report. It is appropriate for the inspector to expect all records will be available for inspection up to the date of notification.

*241(c) Records of internal rail inspections required by § 213.237 shall specify the—*

- (1) Date of inspection;*
- (2) Track inspected, including beginning and end points;*

- (3) *Location and type of defects found under § 213.113;*
- (4) *Size of defects found under § 213.113, if not removed prior to the next train movement;*
- (5) *Initial remedial action taken and the date thereof; and*
- (6) *Location of any track not tested pursuant to § 213.237(g).*

**Guidance:** Internal rail inspection records are now required to include the date of inspection, track identification and milepost for each location tested, type of defect found and size, and initial remedial action as required by § 213.113. However, if the defect is repaired or removed prior to the next train movement, the size of the defect is not required. Paragraph (c) also requires that the records document all tracks that do not receive a valid test pursuant to § 213.237(g). Section § 213.237(g) specifies that if rail surface conditions prohibit the railroad from conducting a proper search for rail defects, during a test, that test will not fulfill of that rail does not fulfill the requirements of §§ 213.237(a) and (c), which requires a search for internal defects at specific intervals..

*241(d) The track owner shall retain a rail inspection record under paragraph (c) of this section for at least two years after the inspection and for one year after initial remedial action is taken.*

**Guidance:** This information is vital for FRA to determine compliance with the rail integrity and inspection requirements in § 213.113 and § 213.237.

*241(e) The track owner shall maintain records sufficient to demonstrate the means by which it computes the service failure rate on all track segments subject to the requirements of § 213.237(a) for the purpose of determining compliance with the applicable service failure rate target.*

**Guidance:** Rail inspection records must be maintained to demonstrate compliance with §§ 213.237(a) and (c). This requirement is intended to provide sufficient information to determine that accurate data concerning detected defects is used by the railroads as input into the performance-based test frequency formula. FRA requests for records of rail inspections demonstrating compliance with required test frequencies shall be made by a designated FRA Rail Integrity specialist; each track owner will designate a person within its organization whom the Rail Integrity specialists will contact when requesting records of rail inspections.

*241(f) Each track owner required to keep inspection records under this section shall make those records available for inspection and copying by FRA upon request.*

*241(g) For purposes of complying with the requirements of this section, a track owner may maintain and transfer records through electronic transmission, storage, and retrieval provided that—*

- (1) *The electronic system is designed so that the integrity of each record is maintained through appropriate levels of security such as recognition of an electronic signature, or another means, which uniquely identifies the initiating person as the author of that record. No two persons shall have the same electronic identity;*
- (2) *The electronic storage of each record shall be initiated by the person making the inspection within 24 hours following the completion of that inspection;*
- (3) *The electronic system shall ensure that each record cannot be modified in any way, or replaced, once the record is transmitted and stored;*

- (4) *Any amendment to a record shall be electronically stored apart from the record which it amends. Each amendment to a record shall be uniquely identified as to the person making the amendment;*
- (5) *The electronic system shall provide for the maintenance of inspection records as originally submitted without corruption or loss of data;*
- (6) *Paper copies of electronic records and amendments to those records that may be necessary to document compliance with this part shall be made available for inspection and copying by FRA at the locations specified in paragraph (b) of this section; and*
- (7) *Track inspection records shall be kept available to persons who performed the inspections and to persons performing subsequent inspections.*

*[63 FR 34029, June 22, 1998, as amended at 70 FR 66298, Nov. 2, 2005; 79 FR 4259, Jan. 24, 2014]*

**Guidance:** This paragraph contains requirements for maintaining and retrieving electronic records of track inspections. This allows each railroad to design its own electronic system as long as the system meets the specified criteria to safeguard the integrity and authenticity of each record. The provision also requires that railroads make available paper copies of electronic records, when needed by the FRA inspector or by railroad track inspectors.

A track owner may elect to maintain and transfer records through electronic transmission, storage, and retrieval procedures. Each record must have sufficient security to maintain the integrity of the record. Levels of security must identify the person making the inspection as the author of the record. No two individuals will have or share the same electronic signature or identity. If individuals use an electronic signature or identity other than their own, violations or personal liability action should be considered for all parties involved. The integrity of electronic inspection record systems is an extremely sensitive issue. Should the system integrity be compromised, an inspector should immediately contact the appropriate regional track specialist. Should the regional Track specialist be unavailable, the inspector will notify the appropriate Regional Administrator. FRA Headquarters Track Division will also be notified.

The system must ensure that no record can be replaced, deleted, or modified in any way, once the record has been transmitted and stored. Each amendment to a record shall be stored separately from the record it amends. Each amendment must identify the person making the amendment and have sufficient security to maintain the integrity of the amendment.

For electronic records, inspection records must be completed the day of the inspection either on computer or temporarily on paper. The electronic record must then be uploaded to the permanent electronic storage system where the record will be maintained for one year. The uploading of each inspection record must be completed within 24 hours following the completion of the inspection.

An advantage of an electronic system is the associated reduction in paperwork. Therefore, inspectors must rely on viewing records on a terminal or monitor screen whenever it is made available for viewing by the railroad. Although printouts of records must be made available to FRA inspectors, inspectors are discouraged from requesting paper copies of electronic records unless necessary to document noncompliance. A paper copy of an electronic record may be marked "original" and included in the documentation necessary for a violation report when recommending civil penalties.

The railroad inspection records will be furnished upon request at the location specified by the railroad as required in paragraph (b) of this section. A paper copy of any electronic inspection record or amendment will be made available to the railroad inspector or any subsequent railroad inspectors performing inspections of the same territory upon request.

## Appendix

### Appendix A – Superelevation in Inches/Speed MPH

Curve Degree	Table A1 – Elevation Inches – Three Inches Unbalance												
	0	½	1	1½	2	2½	3	3½	4	4½	5	5½	6
0°30'	93	100	107	113	120	125	131	136	141	146	151	156	160
0°40'	80	87	93	98	103	109	113	118	122	127	131	135	139
0°50'	72	78	83	88	93	97	101	106	110	113	117	121	124
1°00'	66	71	76	80	85	89	93	96	100	104	107	110	113
1°15'	59	63	68	72	76	79	83	86	89	93	96	99	101
1°30'	54	58	62	66	69	72	76	79	82	85	87	90	93
1°45'	50	54	57	61	64	67	70	73	76	78	81	83	86
2°00'	46	50	54	57	60	63	66	68	71	73	76	78	80
2°15'	44	47	50	54	56	59	62	64	67	69	71	74	76
2°30'	41	45	48	51	54	56	59	61	63	66	68	70	72
2°45'	40	43	46	48	51	54	56	58	60	62	65	66	68
3°00'	38	41	44	46	49	51	54	56	58	60	62	64	66
3°15'	36	39	42	45	47	49	51	54	56	57	59	61	63
3°30'	35	38	40	43	45	47	50	52	54	55	57	59	61
3°45'	34	37	39	41	44	46	48	50	52	54	55	57	59
4°00'	33	35	38	40	42	44	46	48	50	52	54	55	57
4°30'	31	33	36	38	40	42	44	45	47	49	50	52	54
5°00'	29	32	34	36	38	40	41	43	45	46	48	49	51
5°30'	28	30	32	34	36	38	40	41	43	44	46	47	48
6°00'	27	29	31	33	35	36	38	39	41	42	44	45	46
6°30'	26	28	30	31	33	35	36	38	39	41	42	43	45
7°00'	25	27	29	30	32	34	35	36	38	39	40	42	43
8°00'	23	25	27	28	30	31	33	34	35	37	38	39	40
9°00'	22	24	25	27	28	30	31	32	33	35	36	37	38
10°00'	21	22	24	25	27	28	29	31	32	33	34	35	36
11°00'	20	21	23	24	26	27	28	29	30	31	32	33	34
12°00'	19	20	22	23	24	26	27	28	29	30	31	32	33

Curve Degree	Table A2 - Elevation Inches – Four Inches Unbalance												
	0	½	1	1½	2	2½	3	3½	4	4½	5	5½	6
0°30'	107	113	120	125	131	136	141	146	151	156	160	165	169
0°40'	93	98	104	109	113	118	122	127	131	135	139	143	146
0°50'	83	88	93	97	101	106	110	113	117	121	124	128	131
1°00'	76	80	85	89	93	96	100	104	107	110	113	116	120
1°15'	68	72	76	79	83	86	89	93	96	99	101	104	107
1°30'	62	65	69	72	76	79	82	85	87	90	93	95	98
1°45'	57	61	64	67	70	73	76	78	81	83	86	88	90
2°00'	53	57	60	63	65	68	71	73	76	78	80	82	85
2°15'	50	53	56	59	62	64	67	69	71	73	76	78	80
2°30'	48	51	53	56	59	61	63	65	68	70	72	74	76
2°45'	46	48	51	53	56	58	60	62	64	66	68	70	72
3°00'	44	46	49	51	53	56	58	60	62	64	65	67	69
3°15'	42	44	47	49	51	53	55	57	59	61	63	65	66
3°30'	40	43	45	47	49	52	53	55	57	59	61	62	64
3°45'	39	41	44	46	48	50	52	53	55	57	59	60	62
4°00'	38	40	42	44	46	48	50	52	53	55	57	58	60
4°30'	36	38	40	42	44	45	47	49	50	52	53	55	56
5°00'	34	36	38	40	41	43	45	46	48	49	51	52	53
5°30'	32	34	36	38	39	41	43	44	46	47	48	50	51
6°00'	31	33	35	36	38	39	41	42	44	45	46	48	49
6°30'	30	31	33	35	36	38	39	41	42	43	44	46	47
7°00'	29	30	32	34	35	36	38	39	40	42	43	44	45
8°00'	27	28	30	31	33	34	35	37	38	39	40	41	42
9°00'	25	27	28	30	31	32	33	35	36	37	38	39	40
10°00'	24	25	27	28	29	30	32	33	34	35	36	37	38
11°00'	23	24	25	27	28	29	30	31	32	33	34	35	36
12°00'	22	23	24	26	27	28	29	30	31	32	33	34	35

### Appendix B – Defect Codes

**Note:**

- 1) All codes correspond to the rule text. For example, 0004E1 corresponds to 213.4(e)(1) and 0109B1i corresponds to 213.109(b)(1)(i).
- 2) For penalty schedule, please refer 49 CFR Part 213.
- 3) Defect code descriptions are not exact regulatory language. They are subject to change as needed.

Code	Description
0004A	Excepted track segment not identified in appropriate record.
0004B	Excepted track segment located within 30 feet of an adjacent track subject to simultaneous operation at speeds in excess of 10 mph.
0004C	Excepted track not inspected in accordance with 213.233(c) and 213.235 as specified for class 1 track.
0004D	Train speed exceeds 10 mph on excepted track.
0004E1	Occupied passenger train operated on excepted track.
0004E2	Freight train operated on excepted track with more than five cars required to be placarded in accordance with 49 CFR part 172.
0004E3	Train with a car required to be placarded by 49 CFR Part 172 operated over excepted track within 100 feet of a bridge or in a public street or highway.
0004F	Failure to notify FRA of removal of trackage from excepted status.
0005A	Failure of owner to either bring track into compliance, halt operations, or operate subject to the conditions of this part.
0007A2	Failure of track owner to have persons demonstrate required knowledge, ability to detect deviations and prescribe remedial action, inspection.
0007A3	Failure of person to have written authorization for restoration and renewal.

0007B	Failure of track owner to use qualified persons to inspect track.
0007B2	Failure of track owner to have persons demonstrate required knowledge, ability to detect deviations and prescribe remedial action, restoration and renewal.
0007B3	Failure of person to have written authorization for inspection.
0007C	Failure of track owner to use qualified persons to inspect, restore or renew CWR.
0007C2	Failure to complete comprehensive CWR training course.
0007C3	Failure of track owner to have persons demonstrate required knowledge, ability to detect deviations, CWR.
0007C4	Failure of person to have written authorization to inspect, restore or renew CWR.
0007D	Failure of track owner to use not fully qualified persons to pass trains over broken rails or pull aparts.
0007D2	Train speed exceeds 10 mph over broken rails or pull aparts.
0007D3	Person not watching or prepared to stop train movements over broken rails or pull aparts.
0007D4	Failure to promptly notify and dispatch person(s) fully qualified under 213.7 to the location of the broken rail or pull apart.
0007E	Failure of track owner to properly maintain written records of designation and basis for each designation.
0009B1	Failure to restore other than excepted track to compliance with class 1 stds. Within 30 days after a person designated under 213.7(a) has determined that operations may safely continue over defect(s) not meeting class 1 or excepted track standards.
0009B2	Failure of track owner to enforce, over class 1 defects, the limiting conditions imposed by person designated under 213.7(a).
0011	Proper qualified supervision not provided at work site during work hours when track is being restored or renewed under traffic conditions.
0013	Failure to add dynamic movement to static measurement
0033A1	Drainage or water-carrying facility not maintained.



0033A2	Drainage or water-carrying facility obstructed by debris.
0033A3	Drainage or water-carrying facility collapsed.
0033A4	Drainage or water-carrying facility obstructed by vegetation.
0033A5	Drainage or water-carrying facility obstructed by silting.
0033A6	Drainage or water-carrying facility deteriorated to allow subgrade saturation.
0033A7	Uncontrolled water undercutting track structure or embankment.
0037A	Combustible vegetation around track-carrying structures.
0037B1	Vegetation obstructs visibility of railroad signs and fixed signals.
0037B2	Vegetation obstructs visibility of grade crossing warning signs and signals by the traveling public.
0037C1	Vegetation interferes with railroad employees performing normal trackside duties.
0037C2	Vegetation obstructs passing of day and night signals by railroad employees.
0037C3	Excessive vegetation in toepaths and around switches that interferes with employees performing normal trackside duties.
0037D	Vegetation prevents proper functioning of signal and/or communication lines.
0037E1	Excessive vegetation at train order office, depot, interlocking plant, a carman's building, etc., prevents employees on duty from visually inspecting moving equipment when their duties so require.
0037E2	Excessive vegetation at train meeting points prevents proper inspection by railroad employees of moving equipment.
0037E3	Vegetation brushing sides of rolling stock that prevents employees from visually inspecting moving equipment from their normal duty stations.
0053A	Gage measurement improper.
0053B1	Gage dimension on tangent track exceeds allowable.

0053B2	Gage dimension on tangent track is less than allowable
0053B3	Gage dimension on curved track exceeds allowable
0053B4	Gage dimension on curved track is less than allowable
0053B5	Gage dimension for excepted track exceeds allowable
0055A1	Alinement deviation of tangent track for a 62-foot chord exceeds allowable
0055A2	Alinement deviation of curved track for a 62-foot chord exceeds allowable.
0055A3	Alinement deviation of curved in class 3-5 track for a 31-foot chord exceeds allowable.
0057A1	Maximum crosslevel on a curve in class 1 and 2 track exceeds allowable.
0057A2	Maximum crosslevel on curve in class 3-5 track exceeds allowable.
0057B1	Operating speed exceeds allowable for 3-inches of unbalance, based on curvature and elevation.
0057C1	Operating speed exceeds allowable for 4-inches of unbalance, based on curvature and elevation.
0057D	Operating speed exceeds allowable for a FRA approved unbalance based on curvature and elevation for contiguous high speed track exceeds allowable.
0059A	Where fixed physical conditions are not considered, operating speed based on curvature and actual minimum elevation in a curve exceeds allowable
0059B	Improper elevation runoff in a spiral exceeds allowable
0063A1	Runoff in any 31-feet of rail at end of raise exceeds allowable.
0063A10	Crosslevel differences in all of six or more consecutive pairs of staggered joints in class 2-5 track exceeds allowable.
0063A2	Deviation from uniform profile on either rail exceeds allowable.
0063A3	Deviation from zero crosslevel at any point on tangent track exceeds allowable

0063A4	Reverse crosslevel on curve track exceeds allowable
0063A5	Difference in crosslevel (warp) between any two points less than 62-feet apart on tangent track exceeds allowable.
0063A6	Difference in crosslevel (warp) between any two points less than 62-feet apart on curve track between spirals exceeds allowable.
0063A7	Difference in crosslevel (warp) between any two points less than 62-feet apart on spiral track exceeds allowable.
0063A8	Variation in crosslevel per 31-feet on a physically restricted length spiral exceeds allowable.
0063A9	Where elevation at any point in curve track equals or exceeds six inches, the difference in crosslevel within 62-feet between that point and a point with greater elevation exceeds allowable
0103A	Fouled or insufficient ballast failing to transmit and distribute loading
0103B	Fouled or insufficient ballast failing to restrain the track laterally, longitudinally or vertically.
0103C	Fouled ballast failing to provide adequate drainage for the track.
0103D	Fouled or insufficient ballast failing to maintain proper geometry.
0109A	Crossties made of unsound material
0109B1i	39-foot segment of track does not have sufficient number of crossties to provide effective support to hold gage within limits prescribed in part 213.53(b).
0109B1ii	39-foot segment of track does not have sufficient number of crossties to provide effective support that will maintain surface within the limits prescribed by part 213.63.
0109B1iii	39-foot segment of track does not have sufficient number of crossties to provide effective support that will maintain alinement within the limits prescribed by part 213.55.
0109B2	Crossties not effectively distributed to support a 39-foot segment of track.
0109B3	No effective support ties within the prescribed distance from a joint.

0109B4	Failure to maintain the minimum number of crossties per FRA track class for each 39-foot segment of track as indicated in table in this section.
0109C1	Crossties, other than concrete, that meet the minimum requirements of part 213.109 (b)(4), are broken through.
0109C2	Crossties, other than concrete, that meet the minimum requirements of part 213.109 (b)(4), are split or otherwise impaired to the extent the crosstie will allow the ballast to work through, or it will not hold spikes or rail fasteners.
0109C3	Crossties, other than concrete, that meet the minimum requirements of part 213.109 (b)(4), are so deteriorated that the crosstie plate or base of the rail can move laterally 1/2-inch relative to the crosstie.
0109C4	Crossties, other than concrete, that meet the minimum requirements of part 213.109 (b)(4), are cut by the crosstie plate through more than 40 percent of a crosstie's thickness.
0110A	Failure to maintain and operate GRMS within minimum design requirements over designated GRMS line segments
0110A1	Failure to notify FRA at least 30 days prior to the designation of a GRMS line segment
0110A2	Failure to notify FRA at least 10 days prior to the removal of a line segment from GRMS designation
0110B1	Failure to provide required information identifying a GRMS line segment
0110C	Failure to provide sufficient technical data to establish compliance with minimum GRMS design requirements
0110G	Failure of GRMS to provide analog trace of specified parameters
0110H	Failure of GRMS to provide exception report listing of specified parameters
0110I	Failure to provide exception report listing to par. 213.7 individual prior to next inspection required under par. 213.333
0110J1i	Failure to maintain and make available documented calibration procedures on GRMS vehicle
0110J1ii	Failure to initiate a daily instrument verification procedure
0110J2	Failure to maintain PTLF accuracy within five-percent of 4,000 reading

0110K	Failure to meet training requirements.
0110L	Failure to initiate required remedial action for exceptions listed on GRMS record of lateral restraint
0110M1i	Gage widening exceeds allowable measured with PTLF
0110M5	Failure to provide functional PTLF to par. 213.7 individual whose territory is subject to requirements of par. 213.110
0110M6	Failure to restore contact between rail and lateral rail restraint components
0110N	Failure to keep GRMS records as required
0110O	Failure to conduct GRMS inspections at required frequency
0113A	Operation continued over defective rail without required remedial action.
0113B	Rail defect originating from bond wire attachment [where a defect results from a bond wire attachment, FRA inspectors must cite this defect code and also include a description of the applicable rail defect as described in §213.113]
0113B1	Transverse fissure
0113B10	Ordinary break
0113B11	Damaged rail
0113B12	Flattened rail
0113B13	Bolt-hole crack
0113B14	Broken or defective weld
0113B15	Head web separation
0113B2	Compound fissure
0113B3	Horizontal split head

0113B4	Vertical split head
0113B5	Split web
0113B6	Piped rail
0113B7	Broken base
0113B8	Detail fracture
0113B9	Engine burn fracture
0115A1	Rail-end mismatch on tread of rail exceeds allowable.
0115A2	Rail-end mismatch on tread of rail exceeds allowable (CWR).
0115A3	Rail-end mismatch on gage side of rail exceeds allowable.
0115A4	Rail-end mismatch on gage side of rail exceeds allowable (CWR).
0118A1	Failure of track owner to develop and implement written CWR procedures.
0118A2	Failure to comply with written CWR procedures.
0118A3	Failure of track owner to develop a training program for the implementation of their written CWR procedures.
0118C	Failure of track owner to comply with existing CWR plan.
0118E1	Failure of track owner to file a revised CWR plan with associate administrator of safety/chief operating officer within 30 days of revision.
0118E2	Failure of track owner to re-submit a conforming plan within 30 days of receipt of final submission decision.
0119A	Failure to comply with written CWR procedures - installation and adjustment
0119B	Failure to comply with written CWR procedures - anchoring or fastening requirements
0119C	Failure to comply with written CWR procedures - joint installation and maintenance procedures

0119D	Failure to comply with written CWR procedures - maintaining desired rail installation temperature range
0119E	Failure to comply with written CWR procedures - curved track
0119F	Failure to comply with written CWR procedures - train speed
0119G	Failure to comply with written CWR procedures - physical track inspections
0119H	Failure to comply with written CWR procedures - CWR joint inspection
0119I	Failure to comply with written CWR procedures - training
0119J	Failure to comply with written CWR procedures - recordkeeping
0119K	Car procedures and revisions not available at job site or maintained in one manual
0121A1	Rail joint not of structurally sound design and dimension (jointed track)
0121A2	Rail joint not of structurally sound design and dimension (CWR).
0121B1	Cracked or broken joint bar in classes 3 through 5 track (other than center-break) (jointed track)
0121B2	Cracked or broken joint bar in classes 3 through 5 track (other than centerbreak) (CWR)
0121B3	Cracked or broken insulated joint bar in classes 3 through 5 track (other than centerbreak) (CWR).
0121B4	Worn joint bar allows excessive vertical movement of rail in joint in classes 3 through 5 track (jointed track)
0121B5	Worn joint bar allows excessive vertical movement of rail in joint in classes 3 through 5 track (CWR).
0121C1	Center cracked or broken joint bar (jointed track)
0121C2	Center cracked or broken joint bar (CWR).
0121C3	Center cracked or broken insulated joint bar (CWR)
0121D1	Less than 2 bolts per rail at each joint for conventional jointed rail in classes 2 through 5 track.
0121D2	Less than 1 bolt per rail at each joint for conventional jointed rail in class 1 track.

0121E	Less than 2 bolts per rail at any joint in continuous welded rail.
0121F1	Loose joint bars (jointed track)
0121F2	Loose joint bars (CWR).
0121G1	Torch-cut or burned-bolt hole in rail in classes 2 through 5 track (jointed track)
0121G2	Torch-cut or burned-bolt hole in rail in classes 2 through 5 track (CWR).
0121H1	Joint bar reconfigured by torch cutting in classes 3 through 5 track (jointed track)
0121H2	Joint bar reconfigured by torch cutting in classes 3 through 5 track (CWR).
0122Ai	Torch cut rail applied in class 3 through 5 track for other than emergency.
0122Aii	Failure to remove torch cut rails within specified time frame.
0122B1	Failure to remove non-inventoried torch cut rail within 30 days of discovery.
0122B2	Train speed exceeds allowable over non-inventoried torch cut rail.
0123A	Insufficient tie plates in class 3 through 5 track.
0123B	Object between base of rail and the bearing surface of the tie plate causing concentrated load.
0127A	Failure of fastening components to effectively maintain gage within the limits described in part 213.53(b)
0127A2	Insufficient fasteners in a track segment.
0127A3	Insufficient fasteners at rail joint.
0127B	Failure of applied rail anchors to provide effective longitudinal restraint
0127C	Failure of fastener placement at insulated joints from performing as intended, or the crosstie does not effectively support the rail
0133A1	Loose, worn, or missing switch clips.



0133A10	Missing switch, frog, or guard rail plates.
0133A11	Loose or missing switch point stops.
0133A12	Loose, worn, or missing frog bolts.
0133A13	Loose, worn, or missing guard rail bolts.
0133A14	Loose, worn or missing guard rail clamps, wedge, separator block, end block, or other components.
0133A15	Turnout or track crossing fastenings not intact or maintained.
0133A16	Obstruction between switch point and stock rail.
0133A17	Obstruction in flangeway of frog.
0133A18	Obstruction in flangeway of guard rail.
0133A2	Loose, worn, or missing clip bolts (transit, side jaw, eccentric, vertical).
0133A3	Loose, worn, or defective connecting rod.
0133A4	Loose, worn, or defective connecting rod fastening.
0133A5	Loose, worn, or defective switch rod.
0133A6	Loose, worn, or missing switch rod bolts.
0133A7	Worn or missing cotter pins.
0133A8	Loose or missing rigid rail braces.
0133A9	Loose or missing adjustable rail braces.
0133B	Insufficient anchorage to restrain rail movement.
0133C	Flangeway less than 1 1/2 inches wide.
0135A1	Stock rail not securely seated in switch plates.

0135A2	Stock rail canted by overtightening rail braces.
0135B1	Improper fit between switch point and stock rail.
0135B2	Excessive lateral or vertical movement of switch point.
0135B3	Lateral or vertical movement of a stock rail adversely affecting the fit of the switch point to the stock rail.
0135C	Outer edge of wheel contacting gage side of stock rail.
0135D	Heel of switch insecure.
0135E1	Switch stand or switch machine insecure or operable with excessive lost motion.
0135E2	Connecting rod insecure or operable with excessive lost motion.
0135F	Throw lever operable with switch lock or keeper in place.
0135G	Switch position indicator not clearly visible.
0135H1	Unusually chipped or worn switch point.
0135H2	Improper switch closure due to metal flow.
0135I	Use of tongue and plain mate where speeds exceed class one.
0137A	Insufficient flangeway depth.
0137B	Frog point chipped, broken, or worn in excess of allowable.
0137C	Tread portion of frog worn in excess of allowable.
0137D	Use of flange bearing frog where speed exceeds that permitted by class 1.
0137E	Severe frog condition not otherwise provided (advisory only cannot be used solely to recommend violation)
0139A	Outer edge of wheel contacting side of spring wing rail.
0139B	Toe of wing rail not fully bolted and tight.

0139B1	Ties under or wing rail not solidly tamped.
0139C1	Bolt-hole defect in spring frog.
0139C2	Head and web separation in spring frog.
0139D	Insufficient compression in spring to hold wing rail against point rail.
0139E	Excessive clearance between hold-down housing and horn.
0141A	Raised guard worn excessively.
0141B	Frog point rebuilt before restoring guarding face.
0143A1	Guard check gage less than allowable.
0143A2	Guard face gage exceeds allowable.
0143A3	Cracked or broken guard rail.
0205A	Derail not clearly visible.
0205B	Derail operable when locked.
0205C1	Loose, worn, or defective parts of derail.
0205C2	Insecure derail or stand
0205D1	Improper size derail.
0205D2	Improperly installed derail.
0233A	Track inspected by other than qualified designated individual.
0233B	Track being inspected at excessive speed.
0233B1	One inspector inspecting more than two tracks or inspecting tracks with centers greater than allowable.
0233B2	Two inspectors inspecting more than four tracks or inspecting tracks with centers greater than allowable.

0233B3i	Main track not traversed within the required frequency.
0233B3ii	Siding track not traversed within the required frequency.
0233C	Failure to inspect at required frequency.
0233D	Failure to initiate remedial action for deviations found.
0234B1	Failure to inspect at required frequency on class 4 and 5 main track and class 3 main track with regularly scheduled passenger service, exceeding 40 million gross tons annually, at least twice each calendar year, with no less than 160 days between inspect
0234B2	Failure to inspect at required frequency on class 4 and 5 main track and class 3 main track with regularly scheduled passenger service equal to or less than 40 million gross tons annually, at least once per calendar year.
0234B3	Failure to inspect at required frequency on class 3, 4, and 5 main track with exclusively passenger service, either an automated inspection or walking inspection once per calendar year.
0234B4	Failure to inspect at required frequency in accordance with paragraph (b)(1) or (b)(2) of this section because of train operation interruption.
0234C	Sections of tangent track greater than 600 feet constructed of concrete crossties, not inspected
0234D1	Automated inspection measurement system incapable of measuring and processing rail seat deterioration.
0234E	Failure of automated inspection measurement system to produce an exception report.
0234F	Failure to maintain and make available to FRA a record of the inspection data and exception record for the track inspected.
0234G	Failure to maintain proper procedures for data integrity.
0234H	Failure to provide annual rail seat deterioration training.
0235A1	Failure to inspect turnouts at required frequency.
0235A2	Failure to inspect track crossings at required frequency.

0235A3	Failure to inspect lift rail assemblies or other transition devices on moveable bridges at required frequency.
0235B	Failure to operate specified switches in classes 3 through 5.
0235C	Switch, turnout, track crossing or transition device used less than once a month and not inspected on foot before use
0235C1	Track used less than once a month not inspected on foot before use
0237A	Failure to inspect rail for internal defects at required frequency.
0237B	Failure of equipment to inspect rail at joints.
0237C	Defective rail not marked properly.
0237E	Improper action taken after expiration limits of previous internal rail defect search.
0239A	Failure to conduct special inspections when required.
0241A	Failure to keep records as required.
0241B1	Failure of inspector to complete report the day of the inspection.
0241B2	Failure of inspector to sign report.
0241B3	Failure to indicate the nature of deviation.
0241B4	Failure of inspector to provide required information.
0241B5	Failure to record required periodic or follow-up CWR joint inspection
0241C	Failure of rail inspection record to provide required information.
0241D	Failure to make records available for copying and inspection.
0241E1	Electronic system does not maintain the integrity of each record.
0241E2	Electronic storage not initiated within 24 hours.

0241E3	Electronic system allows record or amendments to be modified.
0241E4	Electronic amendments not stored separately from record.
0241E4i	Person making electronic amendment not identified.
0241E5	Electronic system corrupts or losses data.
0241E6	Paper copies of records not made available for inspection and copying.
0241E7	Inspection reports not available to inspector or subsequent inspectors.

**Appendix C – Rail Mill Branding and Key Dimensions**

Weight	Type	Rail Mill/Branding Designations													
		U.S. Steel	Bethlehem	Illinois	Old Illinois	Carnegie	Tennessee	Lackawanna	Midvale	Colorado	Inland	Cambria	MD/PA	Dominion	Algoma
70	ARA-A			7020		7020	7020	7031							
70	ARA-B		174	7030		7030	7030	7032							
70	ASCE	7040	70AS	7040	7010	7040	7040	700	532	701		237			
70	Bangor Aroostook		70-BA					703				97			
70	Chicago & Alton				7002										
70	Pennsylvania			7033	7005	7033	7033		504			57			
72	CP Sandberg														
72	Chicago NW	7250	72NP	7250	7201	7250	7250		581						
72	Spokane							722							
74	MD/PA											146			
75	ASCE	7540	75AS	7540	7506	7540	7540	750	529	753		214			
75	Boston & Maine		92					752				92			
75	Lackawanna		75-C					753							
75	Int. Great Northern			7551		7551	7551								
75	Miscellaneous														
75	Missouri Pacific	7550	75MP	7550	7512	7550	7550	754	528						
75	Nat. Ry. Mexico		128												
75	NYC. (Dudley)														
75	MD/PA											87			
75	Seaboard (Dudley)		75DY	7522		7522	7522					221			
75	Union Pacific		75-B	7523	7513	7523	7523			754		249			
75	Union Pacific	7524	75SP	7524		7524	7524			757					
76	MD/PA											216			
78	Great Northern				77501			775							
78	Old Colony		78-OC									98			
79	MD/PA											76			
80	Frictionless		79.5-C												
80	ARA-A	8020	80-RA	8020		8020	8020	8031		801					
80	ARA-B	8030	80-RB	8030		8030	8030	8032	569	802					
80	ASCE	8040	80AS	8040		8040	8040	800	530	800	8040	251			
80	Canadian Northern		804	8010		8010	8010	804							
80	DUDLEY	8022	80DY	8022		8022	8022					220			

Weight	Type	Rail Mill/Branding Designations														
		U.S. Steel	Bethlehem	Illinois	Old Illinois	Carnegie	Tennessee	Lackawanna	Midvale	Colorado	Inland	Cambria	MD/PA	Dominion	Algoma	Sydney
80	Frictionless		80-MC-F													
80	Great Northern				8009			802								
80	Hocking Valley								540							
80	New York Central		220	8022	8008	8022	8022	801	543							
85	Asce	8540	85AS	8540	8504	8540	8540	850	531	851	8540	235				
85	C.B. & Q.	8543	85-CB	8543	8506	8543	8543	855		852						
85	Canadian Pacific	8524	85CP	8524		8524	8524	856			8524		8501	113		
85	Head Free – CP												8504	137		
85	Denver & RG									850						
85	D. & R.G. / C & S									853						
85	Great Northern		854	8553	8509	8553	8553	854								
85	Missouri Pacific	8550	853	8550	8507	8550	8550									
85	N.Y.C. & Stl. / Kcs		85-NK	8521		8521	8521	8531			8521					
85	Pennsylvania	8531	85PS	8531	8530	8531	8531	8530	559		8531					
85	Pennsylvania		85-PR	8533	8503	8533	8533	852	500			67				
85	Seaboard (Dudley)		85DY	8522		8522	8522	851				261				
85	Soo Line	8520		8520		8520	8520									
85	Western Pacific															
90	ARA-A	9020	90RA	9020		9020	9020	9031	563	902	9020					
90	ARA-B	9030	90RB	9030		9030	9030	9032	561	905	9030					
90	ASCE	9040	90AS	9040	9002	9040	9040	900	535		9040	245				
90	A.T. & SF	9021	90SF	9021		9021	9021	9033		903	9021					
90	Chicago NW	9035	90OM	9035		9035	9035	904								
90	Denver Rio Grande									906						
90	Frictionless			9039		9039	9039									
90	Frictionless			9029		9029	9029									
90	Great Northern	9024	90GH	9024		9024	9024			908	9024					
90	Great Northern			9036		9036										
90	Great Northern		90-GN	9034	9010	9034	9034	9030	560	904						
90	Head Free - R.A.	9027	90RA-T	9027		9027	9027			TC1013						
90	Interborough R. T.	9050	90RT	9050		9050	9050	902				77				
90	Lehigh Valley															
90	N.Y.C. (Dudley)		90DY					901								
90	Union Pacific	9023		9023	9003	9023	9023			901						



Weight	Type	Rail Mill/Branding Designations													
		U.S. Steel	Bethlehem	Illinois	Old Illinois	Carnegie	Tennessee	Lackawanna	Midvale	Colorado	Inland	Cambria	MD/PA	Dominion	Algoma
91	Lackawanna		91-DL	9133		9133	9133	911							
92	Frictionless		304												
93	Frictionless		93-NH-F					932							
95	ASCE							950				267			
95	Boston & Albany														
95	W & H Ry. (Dudley)		95-DY					951							
97	Frictionless		97-CO-F												
98	Frictionless		98-PS-F												
100	ARA-A	10020	100RA	10020		10020	10020	10031	565	1003	10020				
100	ARA-B	10030	100RB	10030		10030	10030	10032	564	1002	10030				
100	AREA	10025	100RE	10025		10025	10025			10025	10025				
100	ASCED	10040	100 AS	10040	10001	10040	10040	1000	536			247			
100	Canadian Pacific														100CP-RE
100	Chicago NW	10035	100-OM	10035		10035	10035	1006			10035				
100	Elgin Joliet & East.			10050		10050	10050								
100	Great Northern	10036	100GN	10036		10036	10036	1008							
100	Head Free - R.A.		100RA-T										10004	136	
100	Head Free - R.E.		100RE-T												
100	Interborough R. T.	10005	100RT	10005		10005	10005	1005							
100	N.Y., N.H. & H.	10034	100NH	10034	10004	10034	10034	1002				100			
100	New York Central		100-DY	10022	10003	10022	10022	1001							
100	Pennsylvania	10031	100PS	10031		10031	10031	10030	558		10031				
100	Pennsylvania	10033	100PR	10033	10002	10033	10033	1003	520			96			
100	Reading	10032	100RG	10032		10032	10032	1007							
100	R.W. Hunt.														
101	Lackawanna	10133	101DL	10133		10133	10133	10130							
105	Lackawanna	10533	105DL	10533		10533	10533	1052							
105	Dudley	10524	105DY	10524		10524	10524				10524				
105	New York Central		105-B	10522		10522	10522	1051							
106	Miscellaneous.									1060					
107	N.Y., N.H. & H.	10734	107NH	10734		10734	10734	1072							
110	AREA	11025	110RE	11025		11025	11025			1100	11025				
110	ASCE											268			
110	C.T.A.	11050													

Weight	Type	Rail Mill/Branding Designations													
		U.S. Steel	Bethlehem	Illinois	Old Illinois	Carnegie	Tennessee	Lackawanna	Midvale	Colorado	Inland	Cambria	MD/PA	Dominion	Algoma
110	Great Northern	11036	110GN	11036		11036	11036				11036				
110	Head Free - AREA	11027	110RE-T	11027		11027	11027				11027				
110	Lehigh Valley	11033	110LV	11033		11033	11033								
112	AREA	11228	112RE	11228		11228	11228			1121	11228				
112	Head Free – R.E.	11227	112RE-T	11227		11227	11227				11227HF				
112	CB & Q – TR	11229		11229		11229	11229			1122					
113	Head Free – SP	11327	113RE-T	11327		11327	11327			1130					
115	AREA	11525	115RE	11525		11525	11525			1150	11525				
115	D.R.G.W.									1155					
115	Dudley	11522/23	115DY	11523		11523	11523								
115	Miscellaneous.														
118	Lackawanna		118DL-M												
119	Area	11937								1190	11937				
120	Area			12025		12025	12025								
120	Mfg. Std.		120-MS												
120	New York Central		120-DY					1201							
122	CB (B&O)		122-CB												
125	Pennsylvania		308	12531		12531	12531	12530	584						
126	Frictionless		125.5-PSF												
127	Dudley	12723	127DYM								12723				
127	New York Central		127-DY	12722		12722	12722				12722				
129	CB & Q – TR	12929		12929		12929	12929				12929				
130	AREA	13025	130RE	13025		13025	13025			1300	13025				
130	Head Free – P.S.		130PS-T												
130	Head Free – R.E.	13027	130RE-T	13027		13027	13027				13027		13001	138	
130	Phil. & Reading		130RG												
130	Pennsylvania	13031	130PS	13031		13031	13031	13030	589	1302	13031				
131	Area	13128	131RE	13128		13128	13128			1311	13128				
131	Head Free – R.E.	13127													
132	Area	13225	132RE	13225		13225	13225			1321	13225				
132	Head Free – S.P.	13227	132RE-T	13227		13227	13227			1320					
133	Area	13331	133RE	13331		13331	13331			1330	13331				
135	Central of NJ		135CR												
136	AREA	13637	136RE							1360					

Weight	Type	Rail Mill/Branding Designations														
		U. S. Steel	Bethlehem	Illinois	Old Illinois	Carnegie	Tennessee	Lackawanna	Midvale	Colorado	Inland	Cambria	MD/PA	Dominion	Algoma	Sydney
136	Lehigh Valley	13633	136LV	13633		13633	13633									
136	Lehigh Valley		136-LV													
136	Lehigh Valley		136-LV-M													
136	New York Central		136NYC													
140	AREA/PS	14031	140RE	14031		14031	14031									
141	AREA		141RE													
152	Pennsylvania	15222	152PS	15224		15224	15224									
155	Pennsylvania	15531	155PS	15531		15531	15531									

Weight	Type	Key Rail Dimensions											
		Rail Height	Head Width	Web Thickness	Head Height	Web Height Fishing	Base Height	Head Radius	Web Radius	Top Fillet Radius	Bottom Fillet Radius	Head Bottom Angle	Base Angle
		H	HD	W	HH	WH	BH	RH	RW	R1	R2	A1	A2
70	ARA-A	4 3/4	2 3/8	1/2	1 11/32	2 1/2	29/32	14	14	0.375	0.375	1 to 4	1 to 4
70	ARA-B	4 35/64	2 3/8	33/64	1 23/64	2 17/64	59/64	12	12	0.3125	0.3125	13 deg.	13 deg.
70	ASCE	4 5/8	2 7/16	33/64	1 11/32	2 15/32	13/16	12	12	0.25	0.25	13 deg.	13 deg.
70	Bangor Aroostook	4 3/4	2 7/16	1/2	1 13/32	2 19/32	3/4	12	12	0.25	0.25	12 deg.	12 deg.
70	Chicago & Alton	4 3/8	2 23/64	35/64	1 45/64	1 59/64	3/4					12 deg.	12 deg.
70	Pennsylvania	4 1/2	2 7/16	1/2	1 19/32	2 1/8	25/32	10	8	0.25	0.25	13 deg.	13 deg.
72	CP (Sandberg)	4 15/16	2 1/4	1/2	1 5/8	2 25/64	59/64	6	VERT.	0.375	0.375	15 deg.	15 deg.
72	Chicago NW	4 3/4	2 3/8	9/16	1 13/32	2 1/2	27/32	2				14 deg.	14 deg.
72	Spokane Int'l. Ry.	4 45/64	2 7/16	33/64	1 27/64	2 15/32	13/16	12	12	0.25	0.25	13 deg.	13 deg.
74	MD/PA	4 11/16	2 7/16	9/16	1 3/4	2 3/16	3/4	15	15	0.3125	0.3125	17 deg.	13 deg.
75	ASCE	4 13/16	2 15/32	17/32	1 27/64	2 35/64	27/32	12	12	0.25	0.25	13 deg.	13 deg.
75	Boston & Maine	5	2 1/2	9/16	1 7/16	2 47/64	53/64	12	STR.	0.25	0.25	13 deg.	13 deg.
75	Lackawanna	4 11/16	2 1/2	1/2	1 43/64	2 13/64	13/16	10.5	10	0.3125	0.3125	18 deg.	12° 45'
75	Int. & Grt. Nor	4 3/4	2 1/2	9/16	1 7/16	2 15/32	27/32					13 deg.	13 deg.
75	Miscellaneous	4 3/4	2 1/2	1/2	1 27/32	2 1/8	25/32					13 deg.	13 deg.
75	Missouri Pacific	4 3/4	2 9/16	9/16	1 7/16	2 15/32	27/32	12	30	0.25	0.25	13 deg.	13 deg.
75	Nat. Ry. Mex.	5	2 3/4	1/2	1 3/8	2 7/8	3/4					12 deg.	12 deg.
75	N.Y.C. (Dudley)	5	2 5/8	17/32	1 3/8	2 3/4	7/8	14	14	0.5	0.3125	14 deg.	14 deg.
75	MD/PA	4 3/4	2 1/2	9/16	1 1/2	2 7/16	13/16	12	VERT.	0.25	0.25	13 deg.	13 deg.
75	Seaboard (Dudley)	5	2 9/16	1/2	1 3/8	2 3/4	7/8	14	14	0.5	0.3125	14 deg.	14 deg.
75	Union Pacific	5	2 9/16	33/64	1 3/8	2 13/16	13/16	12	12	0.25	0.25	13 deg.	13 deg.
75	Union Pacific	4 15/16	2 7/16	33/64	1 3/8	2 5/8	15/16	14	14	0.375	0.375	1 to 4	1 to 4
76	MD/PA	4 3/4	2 1/2	1/2	1 11/16	2 1/4	13/16	20	VERT.	0.3125	0.3125	14° 30'	12 deg.
78	Great Northern	5	2 3/8	5/8	1 11/16	2 1/2	13/16					14 deg.	14 deg.
78	Old Colony	4 3/4	2 1/2	17/32	1 3/4	2 7/32	25/32	12	12	0.4375	0.4375	14 deg.	12° 15'
79	MD/PA	4 3/4	2 5/8	5/8	1 5/8	2 11/32	25/32	12	9	0.25	0.25	13 deg.	13 deg.
80	Frictionless	5 3/16	1 15/16	9/16	2 1/32	2 9/32	7/8					13 deg.	13 deg.
80	ARA-A	5 1/8	2 1/2	33/64	1 7/16	2 23/32	31/32	14	14	0.375	0.375	1 to 4	1 to 4
80	ARA-B	4 15/16	2 7/16	35/64	1 15/32	2 15/32	1	12	12	0.3125	0.3125	13 deg.	13 deg.
80	ASCE	5	2 1/2	35/64	1 1/2	2 5/8	7/8	12	12	0.25	0.25	13 deg.	13 deg.
80	Canadian Northern	5	2 9/16	35/64	1 13/32	2 11/16	29/32					13 deg.	13 deg.
80	Dudley	5 1/8	2 21/32	17/32	1 1/2	2 3/4	7/8	14	14	0.5	0.3125	1 to 4	1 to 4
80	Frictionless	5 3/16	1 15/16	9/16	2 1/32	2 9/32	7/8					13 deg.	13 deg.
80	Great Northern	5	2 13/32	5/8	1 5/8	2 1/2	7/8					14 deg.	14 deg.
80	Hocking Valley	5	2 31/64	29/64	1 3/4	2 25/64	7/8					13 deg.	13 deg.

Weight	Type	Key Rail Dimensions											
		Rail Height	Head Width	Web Thickness	Head Height	Web Height Fishing	Base Height	Head Radius	Web Radius	Top Fillet Radius	Bottom Fillet Radius	Head Bottom Angle	Base Angle
		H	HD	W	HH	WH	BH	RH	RW	R1	R2	A1	A2
80	New York Central	5 1/8	2 21/32	17/32	1 1/2	2 3/4	7/8	14	14	0.5	0.3125	1 to 4	1 to 4
85	ASCE	5 3/16	2 9/16	9/16	1 35/64	2 3/4	57/64	12	12	0.25	0.25	13 deg.	13 deg.
85	C.B. & Q.	5 3/16	2 21/32	9/16	1 35/64	2 3/4	57/64					13 deg.	13 deg.
85	Canadian Pacific	5 1/8	2 1/2	9/16	1 7/16	2 11/16	1	8	8	0.375	0.375	1 to 4	1 to 4
85	Head Free – CP	5 1/4	2 29/64	9/16	1 9/16	2 11/16	1	8	8	0.375	0.375	1 to 4	1 to 4
85	Denver & RG	5 1/4	2 1/2	9/16	1 3/4	2 5/8	7/8					13 deg.	13 deg.
85	D. & R.G. / C & S	5 3/8	2 1/2	9/16	1 15/32	2 29/32	1					1 to 4	1 to 4
85	Great Northern	5	2 21/32	21/32	1 19/32	2 1/2	29/32					14 deg.	14 deg.
85	Missouri Pacific	5 7/32	2 15/32	19/32	1 3/4	2 39/64	55/64					13 deg.	13 deg.
85	N.Y.C. & Stl. / Kcs	5 3/8	2 17/32	17/32	1 29/64	2 15/16	63/64	14	14	0.375	0.375	1 to 4	1 to 4
85	Pennsylvania	5 1/8	2 1/2	17/32	1 21/32	2 15/32	1	10	10	0.25	0.25	15 deg.	13 deg.
85	Pennsylvania	5	2 9/16	17/32	1 3/4	2 3/8	7/8	10	8	0.25	0.25	13 deg.	13 deg.
85	Seaboard (Dudley)	5 1/4	2 11/16	17/32	1 5/8	2 3/4	7/8	14	14	0.5	0.3125	1 to 4	1 to 4
85	Soo Line	5 3/8	2 1/2	9/16	1 15/32	2 29/32	1					14° 2' 11"	14° 2' 11"
85	Western Pacific	5 1/4	2 1/2	9/16	1 3/4	2 5/8	7/8	10	VERT.	0.3125	0.3125	13 deg.	13 deg.
90	ARA-A	5 5/8	2 9/16	9/16	1 15/32	3 5/32	1	14	14	0.375	0.375	1 to 4	1 to 4
90	ARA-B	5 17/64	2 9/16	9/16	1 39/64	2 5/8	1 1/32	12	12	0.3125	0.3125	13 deg.	13 deg.
90	ASCE	5 3/8	2 5/8	9/16	1 19/32	2 55/64	59/64	12	12	0.25	0.25	13 deg.	13 deg.
90	AT & SF	5 5/8	2 9/16	9/16	1 15/32	3 5/32	1					1 to 4	1 to 4
90	Chicago NW	5 17/32	2 1/2	1/2	1 17/32	2 31/32	1 1/32	12	12	0.3125	0.3125	13 deg.	13 deg.
90	Denver & RG	5 1/2	2 9/16	9/16	1 5/8	2 7/8	1					14 deg.	14 deg.
90	Frictionless	5 5/8	2 1/4	9/16	2	2 5/8	1					13 deg.	13 deg.
90	Frictionless	6 3/32	1 59/64	9/16	1 15/16	3 5/32	1					1 to 4	1 to 4
90	Great Northern	5 3/8	2 5/8	9/16	1 15/32	2 7/8	1 1/32	12	14	0.4375	0.625	13 deg.	13 deg.
90	Great Northern	5 3/8	2 5/8	19/32	1 15/32	2 7/8	1 1/32					13 deg.	13 deg.
90	Great Northern	5 3/8	2 5/8	5/8	1 1/2	2 7/8	1	14	14	0.375	0.375	13 deg.	13 deg.
90	Head Free - R.A.	5 25/32	2 31/64	9/16	1 5/8	3 5/32	1	14	14	0.375		1 to 4; U = 54°	1 to 4
90	Interborough R.T.	5	2 7/8	11/16	1 25/32	2 11/32	7/8	12	9	0.25	0.25	13 deg.	13 deg.
90	Lehigh Valley	5	2 3/4	5/8	1 53/64	2 15/64	15/16	12	9	0.25	0.25	14 deg.	14 deg.
90	N.Y.C. (Dudley)	5 1/2	2 21/32	9/16	1 1/2	3 1/32	31/32	14	14	0.5	1	1 to 4	1 to 4
90	Union Pacific	5 3/4	2 3/4	17/32	1 1/2	3 3/8	7/8					13 deg.	13 deg.
91	Lackawanna	5 1/4	2 5/8	5/8	1 41/64	2 11/16	59/64	10	8	0.25	0.25	13 deg.	13 deg.
92	Frictionless	5 7/16	1 15/16	5/8	2 3/32	2 5/16	1 1/32					13 deg.	13 deg.
93	Frictionless	6 1/8	2 1/8	19/32	1 13/16	3 3/8	15/16					13 deg.	13 deg.
95	ASCE	5 9/16	2 11/16	9/16	1 41/64	2 63/64	15/16	12	12	0.25	0.25	13 deg.	13 deg.

Weight	Type	Key Rail Dimensions											
		Rail Height	Head Width	Web Thickness	Head Height	Web Height Fishing	Base Height	Head Radius	Web Radius	Top Fillet Radius	Bottom Fillet Radius	Head Bottom Angle	Base Angle
		H	HD	W	HH	WH	BH	RH	RW	R1	R2	A1	A2
95	Boston & Albany	5 1/32	3	5/8	1 9/16	2 15/32	1	14	14	0.5	0.3125	14 deg.	14 deg.
95	W & H Ry. (Dudley)	5 1/32	3	5/8	1 9/16	2 15/32	1	14	14	0.5	0.3125	1 to 4	1 to 4
97	Frictionless	5 7/8	2 1/4	9/16	1 15/16	2 55/64	1 5/64					13 deg.	13 deg.
98	Frictionless	5 27/32	2 1/2	9/16	1 31/32	2 25/32	1 3/32					15 deg.	13 deg.
100	ARA-A	6	2 3/4	9/16	1 9/16	3 3/8	1 1/16	14	14	0.375	0.375	1 to 4	1 to 4
100	ARA-B	5 41/64	2 21/32	9/16	1 45/64	2 55/64	1 5/64	12	12	0.3125	0.3125	13 deg.	13 deg.
100	AREA	6	2 11/16	9/16	1 21/32	3 9/32	1 1/16	14	14	0.375	0.625	1 to 4	1 to 4
100	ASCE	5 3/4	2 3/4	9/16	1 45/64	3 5/64	31/32	12	12	0.25	0.25	13 deg.	13 deg.
100	Canadian Pacific	6 1/16	2 11/16	9/16	1 23/32	3 9/32	1 1/16	14	14	0.375	0.625	1 to 4	1 to 4
100	Chicago NW	5 45/64	2 9/16	9/16	1 39/64	2 61/64	1 9/64	12	12	0.3125	0.3125	13 deg.	13 deg.
100	Elgin Joliet & East.	5 9/16	2 21/32	9/16	1 37/64	2 51/64	1 3/16					1 to 4	1 to 4
100	Great Northern	5 3/4	2 3/4	9/16	1 5/8	3	1 1/8					1 to 4	1 to 4
100	Head Free - R.A.	6 5/32	2 11/16	9/16	1 23/32	3 3/8	1 1/16	14	14	0.375		1 to 4; U = 49°	1 to 4
100	Head Free - R.E.	6 1/16	2 39/64	9/16	1 23/32	3 9/32	1 1/16					1 to 4; U = 57°	1 to 4
100	Interborough R. T.	5 3/4	2 7/8	9/16	1 45/64	3 5/64	31/32	12	12	0.25	0.25	13 deg.	13 deg.
100	N.Y., N.H. & H.	6	2 3/4	19/32	1 23/32	3 11/32	15/16	12	12	0.25	0.25	13 deg.	13 deg.
100	New York Central	6	3	19/32	1 5/8	3 13/32	31/32	14	14	0.5	0.3125	1 to 4	1 to 4
100	Pennsylvania	5 11/16	2 43/64	9/16	1 13/16	2 25/32	1 3/32	10	10	0.3125	0.3125	15 deg.	13 deg.
100	Pennsylvania	5 1/2	2 13/16	5/8	1 7/8	2 11/16	15/16	10	8	0.25	0.25	13 deg.	13 deg.
100	Reading	5 5/8	2 21/32	9/16	1 45/64	2 55/64	1 1/16	12	12	0.3125	0.3125	13 deg.	13 deg.
100	R.W. Hunt.	6	2 9/16	9/16	1 19/32	3 21/64	1 5/64	12	12	0.375	0.375	14 deg.	14 deg.
101	Lackawanna	5 7/16	2 3/4	5/8	1 23/32	2 11/16	1 1/32	10	8	0.25	0.25	13 deg.	13 deg.
105	Lackawanna	6	2 3/4	5/8	1 23/32	3 1/4	1 1/32	10	8	0.25	0.25	13 deg.	13 deg.
105	Dudley	6	3	5/8	1 5/8	3 13/32	31/32	14	14	0.5	0.75	1 to 4	1 to 4
105	New York Central	6	3	5/8	1 5/8	3 13/32	31/32	14	14	0.5	1	1 to 4	1 to 4
106	Misc.	6 3/16	2 21/32	19/32	1 3/4	3 3/8	1 1/16					1 to 4	1 to 4
107	N.Y., N.H. & H.	6 1/8	2 3/4	19/32	1 23/32	3 11/32	1 1/16	12	12	0.25	0.25	13 deg.	13 deg.
110	AREA	6 1/4	2 25/32	19/32	1 23/32	3 13/32	1 1/8	14	14	0.375	0.625	1 to 4	1 to 4
110	ASCE	6 1/8	2 7/8	37/64	1 25/32	3 11/32	1	12	12	0.25	0.25	13 deg.	13 deg.
110	C.T.A.	7	2 3/4	9/16	1 7/8	4 5/16	13/16					14 deg.	9 deg.
110	Great Northern	6 1/2	2 3/4	19/32	1 5/8	3 3/4	1 1/8	14	14	0.5	0.625	1 to 4	1 to 4
110	Head Free - AREA	6 7/16	2 11/16	19/32	1 29/32	3 13/32	1 1/8	14	14	0.375		1 to 4; U = 55° 30'	1 to 4
110	Lehigh Valley	6	2 7/8	19/32	1 7/8	3 1/16	1 1/16					1 to 4	1 to 4
112	AREA	6 5/8	2 23/32	19/32	1 11/16	3 13/16	1 1/8	24	10 & 23	0.375	0.625	1 to 4	1 to 4
112	Head Free - R.E.	6 3/4	2 11/16	19/32	1 13/16	3 13/16	1 1/8	14	10 & 23	0.375		1 to 4; U = 58°	1 to 4

Weight	Type	Key Rail Dimensions											Head Bottom Angle	Base Angle
		Rail Height	Head Width	Web Thickness	Head Height	Web Height Fishing	Base Height	Head Radius	Web Radius	Top Fillet Radius	Bottom Fillet Radius			
		H	HD	W	HH	WH	BH	RH	RW	R1	R2	A1		
112	CB & Q – TR	6 3/4	2 1/2	5/8	1 3/4	3 7/8	1 1/8						1 to 4; U = 77° 45'	1 to 4
113	Head Free – SP	6 13/16	2 11/16	19/32	1 7/8	3 13/16	1 1/8	14	10 & 23	0.375			1 to 4; U = 58°	1 to 4
115	AREA	6 5/8	2 23/32	5/8	1 11/16	3 13/16	1 1/8	10	3 & 14	0.75	0.75		1 to 4	1 to 4
115	D.R.G.W.	6 5/8	2 23/32	3/4	1 11/16	3 13/16	1 1/8						13 deg.	13 deg.
115	Dudley	6 1/2	3	5/8	1 11/16	3 3/4	1 1/16	14	14	0.5	0.75		1 to 4	1 to 4
115	Miscellaneous	6	2 15/16	21/32	1 7/8	3 1/16	1 1/16						1 to 4	1 to 4
118	Lackawanna	6 1/2	2 7/8	5/8	1 29/32	3 1/2	1 3/32						13 deg.	13 deg.
119	AREA	6 13/16	2 21/32	5/8	1 7/8	3 13/16	1 1/8	14	3 & 14	0.75	0.75		1 to 4	1 to 4
120	AREA	6 1/2	2 7/8	5/8	1 25/32	3 17/32	1 3/16						1 to 4	1 to 4
120	Mfg. Std.	6 1/4	2 7/8	5/8	1 29/32	3 5/32	1 3/16	12	12	0.375	0.375		14 deg.	14 deg.
120	New York Central	7	3	21/32	1 5/8	4 5/16	1 1/16	14	20	0.5	1		1 to 4	1 to 4
122	CB (B&O)	6 25/32	2 15/16	21/32	1 15/16	3 39/64	1 15/64	10	3 & 14	0.75	0.75		1 to 2 3/4	1 to 2 3/4, 1 to 13.7
125	Pennsylvania	6 1/2	3	21/32	1 7/8	3 13/32	1 7/32	12	16	0.5	0.75		18 deg.	14 deg.
126	Frictionless	7	1 13/16	11/16	2 3/8	3 13/32	1 7/32						18 deg.	14 deg.
127	Dudley	7	3	21/32	1 11/16	4 5/32	1 5/32						1 to 4	1 to 4
127	New York Central	7	3	21/32	1 11/16	4 5/32	1 5/32	14	18	0.5	0.75		1 to 4	1 to 4
129	CB & Q – TR	7 5/16	2 5/8	21/32	1 27/32	4 9/32	1 3/16						1 to 4	1 to 4
130	AREA	6 3/4	2 15/16	21/32	1 27/32	3 11/16	1 7/32	14	14	0.5	0.75		1 to 4	1 to 4
130	Head Free - P.S.	6 13/16	3	21/32	2 3/16	3 3/8	1 7/32						18°; U = 58° 30'	14 deg.
130	Head Free - R.E.	6 13/16	2 27/32	21/32	2 1/32	3 11/16	1 7/32	14	14	0.5			1 to 4; U = 61°	1 to 4
130	Phil. & Reading	6 27/32	2 15/16	21/32	1 15/16	3 11/16	1 7/32						1 to 4	1 to 4
130	Pennsylvania	6 5/8	3	11/16	2	3 13/32	1 7/32	12	16	0.5	0.75		18 deg.	14 deg.
131	AREA	7 1/8	3	21/32	1 3/4	4 3/16	1 3/16	24	10 & 23	0.5	0.75		1 to 4	1 to 4
131	Head Free - R.E.	7 1/4	2 31/32	21/32	1 7/8	4 3/16	1 3/16	14	10 & 23	0.5			1 to 4; U = 60° 30'	1 to 4
132	AREA	7 1/8	3	21/32	1 3/4	4 3/16	1 3/16	10	8 & 16	3/4 & 5/16	0.875		1 to 4	1 to 4
132	Head Free – S.P.	7 5/16	2 31/32	21/32	1 15/16	4 3/16	1 3/16	14	10 & 23	0.5			1 to 4; U = 60° 30'	1 to 4
133	AREA	7 1/16	3	11/16	1 15/16	3 15/16	1 3/16	10	8 & 16	3/4 & 7/16	0.75		1 to 3	1 to 4.011
135	Central of NJ	6 1/2	3 5/32	3/4	2	3 9/32	1 7/32						14 deg.	14 deg.
136	AREA	7 5/16	2 15/16	11/16	1 15/16	4 3/16	1 3/16	14	8 & 20	3/4 & 5/16	0.75		1 to 4	1 to 4
136	Lehigh Valley	7	2 15/16	21/32	1 7/8	3 7/8	1 1/4						1 to 4	1 to 4
136	Lehigh Valley	7 3/8	2 15/16	11/16	1 25/32	4 3/8	1 7/32						1 to 4	1 to 4
136	Lehigh Valley	7	2 15/16	11/16	1 7/8	3 7/8	1 1/4						1 to 4	1 to 4
136	New York Central	7 9/32	2 15/16	11/16	1 7/8	4 5/32								
140	AREA/PS	7 5/16	3	3/4	2 1/16	4 1/16	1 3/16	10	8 & 27	3/4 & 7/16	0.75		1 to 3	1 to 4
141	AREA	7 7/16	3 1/16	11/16	2 5/32	4 3/32	1 3/16		19 31/32	3/4	3/4		18.4 deg.	14 deg.

Weight	Type	Key Rail Dimensions											
		Rail Height	Head Width	Web Thickness	Head Height	Web Height Fishing	Base Height	Head Radius	Web Radius	Top Fillet Radius	Bottom Fillet Radius	Head Bottom Angle	Base Angle
		H	HD	W	HH	WH	BH	RH	RW	R1	R2	A1	A2
152	Pennsylvania	8	3	11/16	1 27/32	4 7/8	1 9/32	24	6&30	0.5	0.75	14 deg.	14 deg.
155	Pennsylvania	8	3	3/4	2 1/16	4 21/32	1 9/32					18° 26' 10"	14 deg.

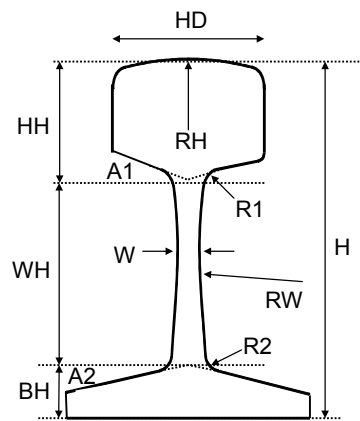



## Appendix D – Use of Portable Track Loading Fixture (PTLF) in Non-GRMS Territory

### Federal Railroad Administration Track Safety Technical Bulletin T-16-01 49 CFR Part 213, Track Safety Standards

**Purpose**—Wide gage is a leading cause of train derailments. To better understand how to prevent derailments caused by gage widening under load, the Federal Railroad Administration (FRA) conducted studies into the safe peak rail forces generated on track, compliant with the Federal Track Safety Standards (TSS). The studies reveal that where the track structure is able to restrain peak forces, derailment risk due to gage-widening is low. FRA implemented Gage Restraint Measurement System (GRMS) technology on an FRA track inspection car to measure and evaluate track strength continuously along the track.<sup>1</sup> GRMS technology simulates the wheel forces produced by a train and measures the ability of the crossties and fasteners to resist gage widening.

A car equipped with GRMS technology, however, is not always available when track conditions warrant an inspection so FRA funded the development of the Portable Track Loading Fixture (PTLF), a more convenient tool to assess track strength in a manner similar to the GRMS technology. The PTLF is a handheld, track loading tool used to test specific track locations exhibiting weakening restraint capacity often evidenced by gage widening.

Proper use of the PTLF is important to determine gage, crosstie, and fastener effectiveness. Typically, to determine a track's maximum gage, inspectors measure unloaded gage and add lateral movement of both rails. Using the PTLF and measuring the rail movement under load provides a means to approximate the rail movements induced by trains. The PTLF is a nondestructive tool that applies just enough lateral loading to take up all of the free play within the rail fastening system. The PTLF measurements can be used to objectively identify noncompliance with Title 49 Code of Federal Regulations (CFR) Sections 213.53, *Gage*; 213.109, *Crossties*; and 213.127, *Rail fastening systems*.

**Background**—In 2002, in a letter to FRA, the Association of American Railroads (AAR) raised concerns about the appropriateness of inspectors using the PTLF in non-GRMS territories. The letter detailed specific concerns about using the PTLF to inspect for compliance with certain requirements of the TSS. In summary, AAR objected to FRA using GRMS/PTLF technology on track segments not chosen by the railroads, and suggested the technology has no regulatory significance, and therefore should not be used on non-GRMS track segments for regulatory enforcement purposes.

In early 2003, FRA responded to AAR's concerns and disagreed with AAR's view that FRA was only permitted to use GRMS/PTLF technology on certain, designated track segments. Nothing in the Federal Track Safety Standards bars the use of a PTLF by an Inspector on any track. While the use of a PTLF is expressly required under the GRMS standard, FRA has found it is a

---

<sup>1</sup> Please note FRA's use of this technology was independent of, and in no way intended to implicate the requirements of 49 CFR § 213.110, *Gage restraint measurement systems*.

very effective tool for use in non-GRMS track to determine compliance with 49 CFR § 213.13, *Measuring track not under load*.

Nevertheless, and despite prevalent use by the rail industry, FRA decided to suspend PTLF usage in non-GRMS territories.

**PTLF Analysis and Testing**—Since 2003, FRA has collected and analyzed a significant amount of data to validate the PTLF. Comparison analyses demonstrates that PTLF measurements under a 4,000-pound lateral load correlate well with gage measurements by track inspectors and the data from FRA’s Automated Track Inspection Program (ATIP) track inspection cars. FRA’s analyses found the results using the PTLF are relatively insensitive to track class or curvature.

**Exercised Gage Method**—To improve the PTLF, FRA developed the Exercised Gage Method (EGM) to assess track strength using the PTLF.<sup>2</sup> The PTLF is a useful tool for evaluating the gage-holding ability of crossties and fasteners. Rather than a direct measurement, the EGM produces an “applied” gage change value determined by calculating the difference between the loaded gage and the exercised gage measurements (see the attached operating instructions). Field tests show the EGM to be more repeatable than the traditional method and, hence, provide a better indication of the track structure’s ability to maintain and restore gage.

Correct PTLF usage is the key to assess track strength (or gage restraint). Inspectors should be aware of track condition combinations, especially early signs of rail rotation (rail cant) and lateral transition, which are main factors in gage-widening. Crosstie and fastener requirements are satisfied when the applied force of a PTLF increased from 0 to 4,000 pounds does not cause gage widening more than a half of an inch.

**PTLF Procedures**—The PTLF provides a performance-based method for objectively assessing the effectiveness of the crosstie-fastener system. If an Inspector has concerns about the crossties and fasteners, he or she can use the PTLF to quickly determine whether the components can hold track gage. In general, Inspectors should consider applying the PTLF in conjunction with the Geismar™ track gauge when the track structure exhibits indications of lateral movement or when gage change may be obscured. Inspectors may use the PTLF as outlined in the factors listed below.

Inspectors must ensure the PTLF is correctly dated, functional, and calibrated. Inspectors must be vigilant of conditions and combinations associated with both narrow and wide gage, especially early signs of rail rotation, translation, or both.

Inspectors can decide whether or not to use a calibrated PTLF to evaluate gage-widening, determine effectiveness of crosstie and fastening components individually or as a group under 49 CFR §§ 213.53(b); 213.109(c), and 213.127(a)..

Inspectors should use PTLF on all Class 1–5 track, in the presence of a railroad engineering representative, where there is:

- Evidence of gage change of ½ inch or more;
- Obscured gage change or measurement is uncertain (e.g., due to ballast, debris, or mud obscuring movement);

---

<sup>2</sup> Portable Track Loading Fixture Improvement published by FRA as RR 12-21 in December 2012.

- Missing, loose, or sheared fasteners in any 39-foot segment of track with three or more consecutive crossties; or
- Any location where gage validation or defect remediation discovered by automated inspection technology requires verification.

Inspectors should not use PTLF if:

- No railroad engineering representative is present;
- Thermal rail stresses affect gage lateral restraint and render PTLF loading ineffective (conditions may warrant assessing static rail movement evidence only);
- Three or more consecutive crossties not in full contact with crosstie plate or rail;
- Effective gage rods or curve rollover devices are installed in track; or
- Any location where PTLF placement or disassembly is physically restrictive and not in direct contact with running rail neutral axis (i.e., special track work: turnout, bridge guard rail, and rail-rail or rail-highway grade crossing components).

### **Examples of Acceptable PTLF Use**

The operation instructions for both the new (electronic) and the existing (analog) PTLF devices are attached to this TB. The analog version must be used together with a track gauge to determine the lateral rail movements (Exercised Delta), while the electronic version will display Exercised Delta automatically. In either case, Inspectors must use a track gauge to measure track gage, either unloaded or loaded.

The following examples are based on the use of the electronic version of PTLF. If an analog PTLF is used, Inspectors will have to determine the Exercised Delta manually as detailed in the operating manual.

Example 1—On Class 3 track, the unloaded gage measures  $56\frac{7}{8}$  inches. The Exercised Delta from the PTLF is  $\frac{3}{4}$  inch. Adding  $56\frac{7}{8}$ -inch unloaded gage and the  $\frac{3}{4}$ -inch displacement, the loaded gage is  $57\frac{5}{8}$  inches, which is within the 49 CFR § 213.53 gage limit of  $57\frac{3}{4}$  inches. However, if the movement of one rail exceeds the  $\frac{1}{2}$ -inch, the crosstie/fastener condition is noncompliant CFR § 213.109(c)(3).

Example 2—On Class 4 track, the unloaded gage measures  $57\frac{3}{8}$  inches. The Exercised Delta from the PTLF is  $\frac{3}{8}$  inch. Adding  $57\frac{3}{8}$ -inch unloaded gage and the  $\frac{3}{8}$ -inch displacement, the loaded gage is  $57\frac{3}{4}$  inches. Because loaded gage exceeds the limit specified in CFR § 213.53, the condition is noncompliant regardless of rail movement.

## Electronic Portable Track Loading Fixture Operating Instructions

**WARNING: PTLF MAY BE DAMAGED AND MAY CAUSE PERSONAL INJURY, IF NOT USED PROPERLY. DO NOT ATTEMPT TO MODIFY OR USE A PTLF ON ANY RAIL POINT, EXCEPT THE RAIL WEB.**

1. Measure and record initial static (unloaded) track gage using Geismar™ track gauge device. The unloaded track gage, as measured, can be compared to the limits in the Track Safety Standards.
2. Ensure the PTLF is functional, correctly calibrated and dated.
3. Ensure the PTLF tablet is turned on and has connected to the PTLF device.
4. Use the operating instructions for the tablet provided in the latest Electronic PTLF user's manual.
5. Place the PTLF over a crosstie, between rails, so that shoes on each end rest on the rail base (ensure PTLF ends engage the area of the rail web near the base). **Placement in track structure locations other than the rail base is unacceptable.**



**Figure 1.**

6. Apply hydraulic pressure to ram and increase load incrementally to 4,000 pounds (4,000 psi on gauge). Observe the movement of the rail, tie plates, and fastener components to assess which components contribute to poor track strength or gage restraint conditions, as identified.

**CAUTION: DO NOT EXCEED 4,000 psi. EXCESSIVE PRESSURE WILL DAMAGE THE PTLF AND MAY CAUSE PERSONAL INJURY.**

7. Using the Geismar™ track gauge device, measure and record PTLF loaded gage. This loaded gage can be compared to the limits specified in Title 49 Code of Federal Regulations Section 213.53, for determining gage compliance.
8. Gently release PTLF hydraulic pressure. Record the exercised delta from the tablet reading. (Note: It's important to take the loaded gage measurement first to assure all clearance in the tie fastener system is taken out). This exercised delta can be referenced to determine tie and fastener compliance (CFR §§ 213.109 and 213.127).
9. After PTLF release, ensure rail is properly seated in affected tie plates and ask railroad official to confirm.

## Analog Portable Track Loading Fixture Operating Instructions Exercised Gage Procedures

---

**WARNING: PTLF MAY BE DAMAGED AND MAY CAUSE PERSONAL INJURY, IF NOT USED PROPERLY. DO NOT ATTEMPT TO MODIFY OR USE A PTLF ON ANY RAIL POINT, EXCEPT THE RAIL WEB.**

1. Measure and record initial static (unloaded) track gage using Geismar™ track gauge device. The unloaded track gage, as measured, can be compared to the limits in the Track Safety Standards.
2. Ensure the PTLF is correctly dated, functional, and calibrated.
3. Place the PTLF over a crosstie, between rails, so that shoes on each end rest on the rail base (ensure PTLF ends engage the area of the rail web near the base). **Placement in track structure locations other than the rail base is unacceptable.**
4. Apply hydraulic pressure to ram and increase load incrementally to 4,000 pounds (4,000 psi on gauge). Observe the movement of the rail, tie plates and fastener components to assess which components contribute to poor track strength or gage restraint conditions, as identified.

**CAUTION: DO NOT EXCEED 4,000 psi. EXCESSIVE PRESSURE WILL DAMAGE THE PTLF AND MAY CAUSE PERSONAL INJURY.**

5. Using the Geismar™ track gauge device, measure and record PTLF loaded gage. This loaded gage can be compared to the limits specified in 49 CFR § 213.53 for gage compliance.
6. Gently release PTLF hydraulic pressure. After the load is released, measure the gage to which the track returns. This gage, referred to as exercised gage, can be slightly different from the unloaded gage. The difference between the loaded gage and exercised gage is the rail displacement (exercised delta). This exercised delta can be referenced to determine tie and fastener compliance (CFR §§ 213.109 and 213.127)..
7. After PTLF release, ensure rail is properly seated in affected tie plates and ask railroad official to confirm.