

# **Federal Railroad Administration**



## **Track and Rail and Infrastructure Integrity Compliance Manual**

### **Volume II Track Safety Standards Chapter 2 Track Safety Standards Classes 6 through 9**

March 2018

<b>CHAPTER 2 TRACK SAFETY STANDARDS CLASSES 6 THROUGH 9 .....</b>	<b>4</b>
<b>SUBPART G .....</b>	<b>4</b>
§ 213.301 Scope of subpart.....	4
§ 213.303 Responsibility for compliance.....	5
§ 213.305 Designation of qualified individuals; general qualifications .....	8
§ 213.307 Class of track; operating speed limits.....	13
§ 213.309 Restoration or renewal of track under traffic conditions.....	15
§ 213.311 Measuring track not under load.....	16
§ 213.313 Application of requirements to curved track.....	17
§ 213.317 Waivers.....	17
§ 213.319 Drainage .....	18
§ 213.321 Vegetation .....	19
§ 213.323 Track gage.....	21
§ 213.327 Track Alinement.....	21
§ 213.329 Curves, elevation and speed limitations.....	26
§ 213.331 Track surface .....	33
§ 213.332 Combined track alinement and surface deviations.....	38
§ 213.333 Automated vehicle-based inspection systems.....	39
§ 213.334 Ballast; general.....	49
§ 213.335 Crossties.....	51
§ 213.337 Defective rails .....	54
§ 213.339 Inspection of rail in service.....	62
§ 213.341 Initial Inspection of new rail and welds .....	63
§ 213.343 Continuous welded rail (CWR).....	64
§ 213.345 Vehicle/track system qualification. ....	70
§ 213.347 Automotive or railroad crossings at grade .....	78
§ 213.349 Rail-end mismatch .....	78
§ 213.351 Rail joints.....	79
§ 213.352 Torch cut rail.....	81
§ 213.353 Turnouts, track crossings and lift rail assemblies or other transition devices on moveable bridges .....	81
§ 213.355 Frog guard rails and guard faces; gage.....	85
§ 213.357 Derails .....	86
§ 213.359 Track stiffness.....	87
§ 213.361 Right-of-Way.....	88
§ 213.365 Visual inspections .....	88
§ 213.367 Special inspections .....	91
§ 213.369 Inspection records .....	92
Appendix D to Part 213—Minimally Compliant Analytical Track (MCAT) Simulations Used for Qualifying Vehicles to Operate at High Speeds and at High Cant Deficiencies.....	97

**March 2018 Release Note (Volume II, Chapter 2):**

Updated from January 2017 release. Changes include:

- Clarification of the guidance for 213.345(i)
- Format of the document

**Text in italic font of this manual is regulatory language, whereas indented paragraphs provide field guidance for FRA inspectors. Indented paragraphs are not to be construed as regulatory language in any manner.**

## CHAPTER 2 TRACK SAFETY STANDARDS CLASSES 6 THROUGH 9

### Subpart G

#### § 213.301 *Scope of subpart*

*This subpart applies to all track used for the operation of trains at a speed greater than 90 mph for passenger equipment and greater than 80 mph for freight equipment.*

**Guidance:** Subpart G applies to track required to support the passage of passenger and freight equipment in specific speed ranges higher than those permitted over Class 5 track. For those speeds above Class 5, the track and the vehicles operated on the track must be considered as an integral system. This subpart does not apply to technologies such as magnetic levitation that do not use flanged wheel equipment. Subpart G begins at a speed greater than 90 mph for qualified passenger equipment and a speed greater than 80 mph for qualified freight equipment.

The safety requirements for high-speed track classes are contained in Subpart G of the Track Safety Standards (TSS) which covers track classes 6 through 9. As are the standards for the lower track classes, the rules prescribed herein are minimum requirements for safety and the high-speed railroad is encouraged and expected to maintain higher standards.

This subpart is intended to function as “standalone” regulations governing any track belonging to one of these higher track classes. In other words, the track owner needs to refer only to Subpart G for compliance with the TSS for track over which railroads operate trains at the speeds associated with the high-speed track classes. However, if that same track does not meet the requirements in Subpart G at any time, the other subparts (A through F) apply.

These requirements constitute only one of several components comprising a regulatory program permitting trains to travel at high speeds. FRA may also address high-speed issues in regulations outside of Part 213, such as emergency preparedness, wheel conditions, braking systems, and grade crossings. The TSS are an integral part of that larger regulatory scheme.

This manual provides the necessary information for FRA and State personnel to properly interpret and enforce the TSS for the higher track classes. It is not to be construed as a modification, alteration, or revision of the TSS as published.

The inspector should refer to this manual as often as necessary to understand the intent of any particular standard. The requirements prescribed in this subpart apply to specific track and vehicle/track interaction conditions. As in the lower classes, a combination of track conditions, none of which individually amounts to a deviation from the requirements in this part, may require remedial action to ensure safe operations over that track.

The high-speed TSS is based on the fundamental principle that vehicles in the high-speed regime must demonstrate that they will not exceed minimum vehicle/track performance safety limits when operating on specified track. Specific requirements are included for the

qualification of persons engaged in the inspection and maintenance of high-speed track, high-speed track geometry, track structure, and both automated and visual inspections.

The high-speed standards address conditions that exist alone and combinations of track and vehicle/track interaction, which, while individually not in violation of any standard, could nonetheless present a hazard to the safe movement of trains. As in the inspection of the lower classes, if the inspector should encounter a rare event the inspector should bring the condition to the attention of the accompanying railroad official, explain the hazard of such a condition and encourage its rapid removal. Where the inspector is unable, using professional experience, to convince the railroad to initiate some action, the inspector should apply to the regional track specialist for assistance. It is unlikely to find railroad resistance in the removal of recognized safety hazards.

**§ 213.303 Responsibility for compliance**

*303(a) Any owner of track to which this subpart applies who knows or has notice that the track does not comply with the requirements of this subpart, shall --*

- (1) Bring the track into compliance; or*
- (2) Halt operations over that track.*

**Guidance:** This paragraph describes the action that must be taken by the track owner once the owner knows that the track is not in compliance with the TSS. The track owner must:

- (1) Bring the track into compliance by either repairing the defects or imposing an appropriate speed restriction; or
- (2) Remove the track from service.

Only two response options are available under this paragraph. Track owners who know or have notice of noncompliance with this subpart may either bring the track into compliance with the subpart or halt operations over that track. This paragraph does not offer the railroad the option of operating under this subpart with the supervision of a qualified person, as in the standards for track classes 1 through 5. Such an option would permit too much potential for human error. Under this subpart, if a track does not comply with the requirements of its class, it must be repaired immediately or train speeds must be reduced to the maximum speed for the track class with which the track complies. It may be necessary on occasion for the track owner to reduce the class of track to Class 5 or below. When this occurs, the requirements for the lower classes (1–5) will apply.

*303(b) If an owner of track to which this subpart applies assigns responsibility for the track to another person (by lease or otherwise), notification of the assignment shall be provided to the appropriate FRA Regional Office at least 30 days in advance of the assignment. The notification may be made by any party to that assignment, but shall be in writing and include the following --*

- (1) The name and address of the track owner;*
- (2) The name and address of the person to whom responsibility is assigned (assignee);*
- (3) A statement of the exact relationship between the track owner and the assignee;*
- (4) A precise identification of the track;*

- (5) *A statement as to the competence and ability of the assignee to carry out the duties of the track owner under this subpart;*
- (6) *A statement signed by the assignee acknowledging the assignment to that person of responsibility for purposes of compliance with this subpart.*

**Guidance:** This paragraph specifies that the party responsible for compliance can be someone other than the actual owner.

This paragraph requires a track owner to notify FRA, through the appropriate regional office, when the responsibility for compliance with this part is assigned. Notification must contain the specific information required in this paragraph and shall be made 30 days prior to the assignment of the responsibility.

Inspectors must determine the responsible party when recommending civil penalties for noncompliance and alert Chief Counsel when violation reports involve parties other than the track owner.

For class specific defects, it is explicitly apparent to the track owner that they have the option of reclassifying the track to a lower class to bring the track into compliance. For example, § 213.351, Rail Joints, states that “if a joint bar is cracked, broken, or because of wear allows vertical movement of either rail when all bolts are tight, it must be replaced.” Obviously, one of the remedial actions available to the carrier would be to place a speed restriction and reclassify the track to Class 1 or 2. For other defects in the standards, specific classes or remedial actions are not printed in the appropriate section.

Track owners often have questions regarding the remedial actions available when inspectors discover and record turnout defects such as missing or loose frog bolts. The carrier will not find the required remedial action in § 213.353. Because turnouts are designed with certain redundancies, some maintenance personnel suggest that loose or missing components should not always be considered defects unless they present an immediate hazard. However, it is also recognized that these conditions will only deteriorate if left un-repaired.

One loose frog bolt out of several would seldom constitute an immediate hazard, provided that the frog was otherwise secure. On the other hand, a missing cotter pin in a critical location such as in a connecting rod could have serious consequences.

Consider the example of loose or missing rail braces. One or two loose braces are usually not considered to be an immediate hazard, provided that the other braces are in acceptable functional condition to support the stock rail. On the other hand, several consecutively loose braces, especially in the higher track classes, could be much more serious.

Intermittent patches of vegetation that brush the sides of rolling stock may not be an immediate hazard, but more severe vegetation might have the potential of contributing to the injury of an employee who is riding on the side of a car or looking out locomotive cab windows.

As the above examples illustrate, non-class specific defects must be considered in the context of the specific circumstances involved. The existence of a non-class specific

defect under one set of circumstances may not be serious while the identical condition under other circumstances may constitute a serious safety concern.

Although some non-class specific defects may not present an immediate hazard, these conditions will only degrade under train traffic. Therefore, it is important for carrier and FRA inspectors to record these defects so that they will not be left un-repaired. In summary:

- (1) FRA inspectors should record all noncomplying conditions, including non-class specific defects such as loose or missing frog bolts or switch braces. Care must be taken to conduct a thorough inspection, recording the location, type and size of each defect discovered.
- (2) FRA inspectors should evaluate the remedial action taken by the carrier. If an inspector becomes aware that the remedial action, or lack thereof, for a non-class specific defect is not sufficient based on the circumstances, the inspector should seek a more appropriate action from the carrier. For a non-class specific defect which is an imminent hazard such as a missing nut on a connecting rod, the inspector should immediately inquire as to the remedial action planned by the carrier.
- (3) If the railroad does not institute an appropriate remedial action, the inspector should consider recommending a violation. If the railroad has been advised that a violation has been recommended and has not initiated appropriate remedial action, the inspector should be prepared to issue a Special Notice for Repairs, under the guidelines described in Volume I, Chapter 4 of this manual.
- (4) In the case of a non-class specific defect that did not pose an immediate hazard when the defect was recorded, and the inspector discovers that no action was taken within a reasonable time frame after the carrier had knowledge of the defect, the inspector should consider the enforcement options described in item 3 above. In any case, if no appropriate action was taken within a 30-day period, the inspector should consider the enforcement tools outlined above.
- (5) When a railroad inspector discovers a non-class specific defect, as with all defects, the railroad inspector must initiate immediate action in accordance with § 213.365(d). The remedial action taken by the railroad inspector must be recorded in accordance with § 213.369(b). For non-class specific defects, the record must show a reasonable explanation of the action taken. For example, “repaired before next train” would be appropriate for serious conditions. On the other hand, a notation for a defect such as vegetation that indicates the vegetation is scheduled to be cut by a weed mower by a specific date within 30 days may be appropriate. The 30-day period represents only a maximum period that FRA would expect that all non-class specific defects are repaired or other appropriate action taken and is not intended to create a 30-day “grace period” for all defects.
- (6) A non-class specific defect may not pose an immediate hazard for one train movement, but the condition may deteriorate to become a hazard to following trains. It is reasonable to expect that conditions such as loose or missing frog bolts or braces are repaired as quickly as possible. However, a qualified railroad representative under § 213.305 may determine that the condition is not an immediate hazard and decide to call for assistance to make the repairs, or the representative may decide to end the inspection, retrieve the necessary repair materials, and return later to make the repairs. In some cases, the representative may determine that a speed restriction is appropriate.

*303(c) The Administrator may hold the track owner or the assignee or both responsible for compliance with this subpart and subject to the penalties under § 213.15.*

**Guidance:** FRA may hold responsible any party contracted by the track owner to ensure compliance with this part. FRA may hold the track owner, the assignee, or both responsible.

**§ 213.305 Designation of qualified individuals; general qualifications**

*Each track owner to which this subpart applies shall designate qualified individuals responsible for the maintenance and inspection of track in compliance with the safety requirements prescribed in this subpart. Each individual, including a contractor or an employee of a contractor who is not a railroad employee, designated to:*

**Guidance:** Work on or about a track structure supporting qualified high-speed passenger trains demands the employees to be fully aware of the need to perform work properly. This section specifies that the requirements for a person to be qualified under subpart G concern those portions of this subpart necessary for the performance of that person's duties. This section continues to require that a person designated under it has the knowledge, understanding, and ability necessary to supervise the restoration and renewal of subpart G track, or to perform inspections of subpart G track, or both, for which he or she is responsible.

*305(a) Supervise restorations and renewals of track shall meet the following minimum requirements:*

*(1) At least;*

*(i) Five years of responsible supervisory experience in railroad track maintenance in track class 4 or higher and the successful completion of a course offered by the employer or by a college level engineering program, supplemented by special on the job training emphasizing the techniques to be employed in the supervision, restoration, and renewal of high-speed track; or*

*(ii) A combination of at least one year of responsible supervisory experience in track maintenance in Class 4 or higher and the successful completion of a minimum of 80 hours of specialized training in the maintenance of high-speed track provided by the employer or by a college level engineering program, supplemented by special on the job training provided by the employer with emphasis on the maintenance of high-speed track; or*

*(iii) A combination of at least two years of experience in track maintenance in track class 4 or higher and the successful completion of a minimum of 120 hours of specialized training in the maintenance of high-speed track provided by the employer or by a college level engineering program supplemented by special on the job training provided by the employer with emphasis on the maintenance of high-speed track.*

*(2) Demonstrate to the track owner that the individual:*



- (i) Knows and understands the requirements of this subpart that apply to the restoration and renewal of the track for which he or she is responsible;*
  - (ii) Can detect deviations from those requirements; and*
  - (iii) Can prescribe appropriate remedial action to correct or safely compensate for those deviations; and*
- (3) Be authorized in writing by the track owner to prescribe remedial actions to correct or safely compensate for deviations from the requirements of this subpart and successful completion of a recorded examination on this subpart as part of the qualification process.*

**Guidance:** Paragraph (a) concerns qualifications of designated personnel who supervises restorations and renewals of track and paragraph (b) concerns qualifications of designated personnel who inspect track for defects. Note that these paragraphs specify more stringent requirements than their counterparts for Class 1 through to 5 track (213.7(a) and (b)).

Paragraphs (a)(2)(i) and (b)(2)(i) specifically clarify that the requirements for a person to be qualified under this section concern the portions of Part 213 necessary for the person to perform his/her duties. The person is not required to know or understand specific requirements of this part not necessary to fulfill his or her duties. For example, track foremen and inspectors may not be required to know or understand vehicle qualification and testing requirements for high cant deficiency operations in track Classes 6 to 9 in fulfilling their duties.

Under paragraph (a), a person may be qualified to perform restorations and renewals under this subpart in three ways. First, the person may combine 5 or more years of supervisory experience in track maintenance for Class 4 or higher and the successful completion of a course offered by the employer or by a college level engineering program, supplemented by special on-the-job training. Second, a person may be qualified by a combination of at least 1 year of supervisory experience in track maintenance of Class 4 or higher, 80 hours of specialized training or in a college level program, supplemented with on-the-job training. Under the third option, a railroad employee with at least 2 years of experience in maintenance of high-speed track can achieve qualification status by completing 120 hours of specialized training in maintenance of high-speed track, provided by the employer or by a college level engineering program, supplemented by special on-the-job training. For the third option, all or part of the experience required may be non-supervisory.

*305(b) Inspecting track for defects shall meet the following minimum qualifications:*

*(1) At least:*

- (i) Five years of responsible experience inspecting track in Class 4 or above and the successful completion of a course offered by the employer or by a college level engineering program, supplemented by special on the job training emphasizing the techniques to be employed in the inspection of high-speed track; or*
- (ii) A combination of at least one year of responsible experience in track inspection in Class 4 or above and the successful completion of a minimum of 80 hours of specialized training in the inspection of high-speed track provided by the employer or by a college level engineering program, supplemented by special on the job training provided by the employer with emphasis on the inspection of high-speed track; or*

*(iii) A combination of at least two years of experience in track maintenance in Class 4 or above and the successful completion of a minimum of 120 hours of specialized training in the inspection of high-speed track provided by the employer or from a college level engineering program, supplemented by special on the job training provided by the employer with emphasis on the inspection of high-speed track.*

*(2) Demonstrate to the track owner that the individual:*

*(i) Knows and understands the requirements of this subpart that apply to the inspection of the track for which he or she is responsible;*

*(ii) Can detect deviations from those requirements; and*

*(iii) Can prescribe appropriate remedial action to correct or safely compensate for those deviations; and*

*(3) Be authorized in writing by the track owner to prescribe remedial actions to correct or safely compensate for deviations from the requirements in this subpart and successful completion of a recorded examination on this subpart as part of the qualification process.*

**Guidance:** Similar to paragraph (a), under paragraph (b), a person may be qualified to perform track inspections in Classes 6, 7, 8 and 9 by attaining 5 or more years of experience in inspection in track class 4 or higher and by completing a course taught by the employer or by a college level engineering program, supplemented by special on-the-job training. Or, the person may be qualified by attaining a combination of at least 1 year of experience in track inspection in Class 4 and higher and by successfully completing 80 hours of specialized training in the inspection of high-speed track provided by the employer or by a college level engineering program, supplemented with on-the-job training. Finally, a person may be qualified by attaining 2 years of experience in track maintenance in Class 4 and above and by successfully completing 120 hours of specialized training in the inspection of high-speed track provided by the employer or by a college level engineering program, supplemented by special on-the-job training provided by the employer with emphasis on the inspection of high-speed track. For the third option, all or part of the experience required may be non-supervisory. The third option is primarily intended to provide a way for employees with 2 years of experience in the maintenance of high-speed track to gain the necessary training to be qualified to inspect track.

*305(c) Individuals designated under paragraphs (a) or (b) of this section that inspect continuous welded rail (CWR) track or supervise the installation, adjustment, and maintenance of CWR in accordance with the written procedures established by the track owner shall have:*

*(1) Current qualifications under either paragraph (a) or (b) of this section;*

*(2) Successfully completed a training course of at least eight hours duration specifically developed for the application of written CWR procedures issued by the track owner; and*

*(3) Demonstrated to the track owner that the individual:*

*(i) Knows and understands the requirements of those written CWR procedures;*

*(ii) Can detect deviations from those requirements; and*

*(iii) Can prescribe appropriate remedial action to correct or safely compensate for those deviations; and*

- (4) Written authorization from the track owner to prescribe remedial actions to correct or safely compensate for deviations from the requirements in those procedures and successful completion of a recorded examination on those procedures as part of the qualification process. The recorded examination may be written, or it may be a computer file with the results of an interactive training course.*

**Guidance:** This paragraph specifies requirements for qualifications of persons charged with maintaining and inspecting CWR. Training of employees in CWR procedures is essential for high-speed operations. Each person inspecting and maintaining CWR must understand how CWR behaves and how to prevent track buckles and other adverse track reactions to thermal and dynamic loading.

As CWR track has characteristics inherently different than those of traditional jointed rail, track owners are required to designate which individuals are specifically qualified to inspect or supervise the installation, adjustment, and maintenance of CWR. In addition to the qualifications that an individual must have under either paragraph (a) or (b), an individual designated under paragraph (c) must have completed a CWR training course and be well-versed in the maintenance of CWR track as detailed in the track owner's CWR plan. The comprehensive nature of the training course is more important than its duration; therefore, the railroad employee must successfully complete an in depth initial training course of the track owner's written CWR procedures and continue subsequent periodic re-training thereafter, pursuant to the training program required by § 213.343(g). In addition, all individuals qualified on CWR for train operations must successfully complete a recorded examination on the track owner's CWR procedures. This recorded examination may be, for example, a traditional written examination, an electronic file of a computerized interactive training course that concludes with an examination, or a record of a supervisor's oral testing of the employee's knowledge through practical field application. Due to the language of the regulations, track owners have flexibility to test an individual's knowledge to one of the previously stated methods. However, it should be noted that the results of the examination must be recorded so that FRA may inspect the basis for the qualification of an individual under paragraph (c).

*305(d) Persons not fully qualified to supervise certain renewals and inspect track as outlined in paragraphs (a), (b) and (c) of this section, but with at least one year of maintenance of way or signal experience, may pass trains over broken rails and pull-aparts provided that –*

- (1) The track owner determines the person to be qualified and, as part of doing so, trains, examines, and re-examines the person periodically within two years after each prior examination on the following topics as they relate to the safe passage of trains over broken rails or pull-aparts: rail defect identification, crosstie condition, track surface and alignment, gage restraint, rail end mismatch, joint bars, and maximum distance between rail ends over which trains may be allowed to pass. The sole purpose of the examination is to ascertain the person's ability to effectively apply these requirements and the examination may not be used to disqualify the person from other duties. A minimum of four hours training is adequate for initial training;*

- (2) *The person deems it safe, and train speeds are limited to a maximum of 10 mph over the broken rail or pull-apart;*
- (3) *The person shall watch all movements over the broken rail or pull-apart and be prepared to stop the train if necessary; and*
- (4) *Person(s) fully qualified under § 213.305 of this subpart are notified and dispatched to the location as soon as practicable for the purpose of authorizing movements and effectuating temporary or permanent repairs.*

**Guidance:** Paragraph (d) allows employees to be qualified for the specific purpose of authorizing train movements over broken rails or pull-aparts. This section requires the employees to have at least 1 year of maintenance of way or signal experience and a minimum of four hours of training and examination on requirements related to the safe passage of trains over broken rails and pull-aparts. The purpose of the examination is to ascertain the person's ability to effectively apply these requirements. A railroad may use the examination to determine whether or not a person should be allowed to authorize train movements over broken rails or pull-aparts.

The maximum speed over broken rails and pull-aparts shall not exceed 10 mph. However, movement authorized by a person qualified under this subsection may further restrict speed, if warranted, by the particular circumstances. The person qualified under this paragraph must be present at the site and able to instantly communicate with the train crew so that the movement can be stopped immediately, if necessary.

Fully qualified person(s) under § 213.305 must be notified and dispatched to the location promptly to assume responsibility for authorizing train movements and effecting repairs. The word "promptly" is meant to provide the railroad with some flexibility in the event that there is only one train to pass over the condition prior to the time when a fully qualified person would report for a regular tour of duty, or where a train is due to pass over the condition before a fully qualified person is able to report to the scene. Railroads should not use persons qualified under § 213.305(d) to authorize multiple train movements over such conditions for an extended period of time.

*305(e) With respect to designations under paragraphs (a), (b), (c) and (d) of this section, each track owner shall maintain written records of:*

- (1) *Each designation in effect;*
- (2) *The basis for each designation, including but not limited to:*
  - (i) *The exact nature of any training courses attended and the dates thereof;*
  - (ii) *The manner in which the track owner has determined a successful completion of that training course, including test scores or other qualifying results;*
- (3) *Track inspections made by each individual as required by § 213.369. These records shall be made available for inspection and copying by the Federal Railroad Administration during regular business hours.*

**Guidance:** Inspectors may request of an owner, verification of the experience and qualifications of his supervisory (under paragraph (a)) and track inspection personnel (under paragraph (b)) and those supervisory and track personnel who inspect and maintain

CWR (under paragraph (c)) and those qualified to pass trains over broken rails or pull-aparts (under paragraph (d)). Each inspector shall maintain an up-to-date list of the owner's qualified personnel to determine the effectiveness of their inspection or work. The submission of a seniority roster or job awarding bulletin is not to be considered as satisfactory identification of qualified employees or as a basis for their designation. Specific names of individuals should be made available in writing by the owner.

If the inspector is in doubt as to the qualifications of the owner's supervisory or inspection personnel, the inspector should examine the owner's inspection records. The TSS require the retention of required track inspection reports for 1 year at the owner's division office. Should the records consistently fail to reflect the actual track condition, question can be raised as to the competence and/or qualifications of the person(s) establishing the record.

When in doubt as to the qualifications of an owner's supervisors or inspectors, the inspector should discuss the matter with the owner.

Failure of the owner to have and maintain written records of designating employees or the basis for each designation is a deviation from the TSS. Incomplete qualification records would also constitute a deviation from the standards. Designated employees include supervisors, inspectors, those supervisors and inspectors qualified on CWR, and those partially qualified to pass trains over broken rails and pull-aparts.

#### Defect Codes

0305A3	Failure of track owner to provide written authorization to qualified designated individuals to supervise restoration and renewals.
0305B3	Failure of track owner to provide written authorization to qualified designated individuals to inspect track for defects.
0305C4	Failure of track owner to provide written authorization to qualified designated individuals - CWR.
0305D	Failure to use qualified person to pass trains over broken rails or pull-aparts.
0305D2	Train speed exceeds 10 m.p.h. over broken rails or pull-aparts.
0305D4	Failure to promptly notify and dispatch person fully qualified under 213.7 to the location of the broken rail or pull apart.
0305E	No written record of names of qualified persons to supervise restorations and renewals of track under traffic and/or to inspect track for defects, or to pass trains over broken rails or pull-aparts, or to maintain or inspect CWR.

#### § 213.307 Class of track; operating speed limits

307(a) Except as provided in paragraph (b) of this section and §§ 213.329, 213.337(a) and 213.345(c), the following maximum allowable operating speeds apply:

<b>Over track that meets all of the requirements prescribed in this subpart for</b>	<b>The maximum allowable operating speed for trains<sup>1</sup></b>
Class 6 track	110 m.p.h.
Class 7 track	125 m.p.h.
Class 8 track	160 m.p.h. <sup>2</sup>
Class 9 track	220 m.p.h. <sup>2</sup>

<sup>1</sup> Freight may be transported at passenger train speeds if the following conditions are met:

- (1) *The vehicles utilized to carry such freight are of equal dynamic performance and have been qualified in accordance with §213.329 and §213.345.*
- (2) *The load distribution and securement in the freight vehicle will not adversely affect the dynamic performance of the vehicle. The axle loading pattern is uniform and does not exceed the passenger locomotive axle loadings utilized in passenger service, if any, operating at the same maximum speed.*
- (3) *No carrier may accept or transport a hazardous material, as defined at 49 CFR 171.8, except as provided in Column 9A of the Hazardous Materials Table (49 CFR 172.101) for movement in the same train as a passenger-carrying vehicle or in Column 9B of the Table for movement in a train with no passenger-carrying vehicles.*

<sup>2</sup> *Operating speeds in excess of 125 m.p.h. are authorized by this part only in conjunction with FRA regulatory approval addressing other safety issues presented by the railroad system. For operations on a dedicated right-of-way, FRA's regulatory approval may allow for the use of inspection and maintenance criteria and procedures in the alternative to those contained in this subpart, based upon a showing that at least an equivalent level of safety is provided.*

**Guidance:** The maximum speed for Class 9 track has been raised to 220 m.p.h. from the 1998 rule. This is to address the need for the highest speeds likely to be achieved by the most forward-looking, high-speed rail projects. FRA conducted research and vehicle/track interaction simulations at higher speeds and concluded that Class 9 vehicle/track safety standards can be safely extended up to 220 m.p.h. - the highest speeds proposed to date.

The rule requires the testing and evaluation of equipment for qualification purposes at a speed of 5 m.p.h. above the maximum intended operating speed, in accordance with § 213.345. For example, this will require equipment intended to operate at Class 8 track's maximum speed of 160 m.p.h. to be tested at 165 m.p.h.. The rule makes clear that operating at speeds up to 165 m.p.h. for vehicle qualification purposes under this subpart will be permitted to continue on Class 8 track, subject to the requirements for the planning and safe conduct of such test operations. These test operations are distinct from service operations on Class 8 track that will be limited to a maximum speed of 160 m.p.h..

Footnote 1 provides conditions under which freight may be transported at passenger train speeds. The second clause of footnote 1 references passenger locomotive axle loadings used in passenger service along with the freight. This clause contains the words "if any" after the reference to passenger service, to make clear that there need not be any passenger service on the same line with the freight service.

Footnote 2 has also been revised from the 1998 rule and provides that operating speeds in excess of 125 m.p.h. are authorized by this part only in conjunction with FRA regulatory approval addressing other safety issues presented by the railroad system. This provision recognizes that while high-speed rail operations are subject to FRA regulatory approval, it is no longer necessary to specify that FRA regulatory approval be provided through an RPA as required in the 1998 rule. This footnote also recognizes that high-speed rail operation begins at speeds above 125 m.p.h., consistent with FRA's Tier II Passenger Equipment Safety Standards in 49 CFR part 238.

In addition, Footnote 2 provides that for operations on a dedicated right-of-way, FRA's regulatory approval may allow for the use of inspection and maintenance criteria and procedures in the alternative to those contained in this subpart, based upon a showing that at least an equivalent level of safety is provided. This addition acknowledges the unique system attributes inherent in a dedicated right-of-way operation, allowing for FRA approval of

alternative criteria and procedures that are appropriate and safe in such a defined operating environment.

*307(b) If a segment of track does not meet all of the requirements for its intended class, it is to be reclassified to the next lower class of track for which it does meet all of the requirements of this subpart. If a segment does not meet all of the requirements for Class 6, the requirements for Classes 1 through 5 apply.*

**Guidance:** As in the lower classes, the high-speed standards classify track solely on the basis of authorized speeds of freight and passenger trains, irrespective of traffic density, axle loads, trailing tonnage, curvature, grades, or rail weight. Thresholds are specified in the TSS for each class of track. A deviation beyond the limiting thresholds requires repair, or reduction of speeds to the appropriate class. If the condition does not meet the requirements for track classes 6 through 9, the owner may reduce the speed to comply with the requirements for Classes 1 through 5.

All equipment, whether used for passenger or freight, must demonstrate the same vehicle/track performance and be qualified on the high-speed track. Hazardous materials, except for limited and small quantities, may not move in bulk on trains operated at high-speeds.

**Defect Codes**

0307A	Train speed exceeds 200 mph without FRA approval.
0307A1	Freight transported at passenger train speeds in unqualified vehicles.
0307A2	Load distribution & securement in the freight vehicle adversely affects the dynamic performance of the vehicle or the axle loading pattern is not uniform & exceeds the passenger locomotive axle loadings in passenger trains at the same maximum speed.
0307A3	Carrier accepted or transported a hazardous material defined in 49 CFR Part 171.8 which is not acceptable for movement.
0307A2i	Trains operated in excess of 150 mph not in conjunction with a rule of particular applicability addressing other safety issues presented by the system.

**§ 213.309 Restoration or renewal of track under traffic conditions**

*309(a) Restoration or renewal of track under traffic conditions is limited to the replacement of worn, broken, or missing components or fastenings that do not affect the safe passage of trains.*

*309(b) The following activities are expressly prohibited under traffic conditions:*

- (1) Any work that interrupts rail continuity, e.g., as in joint bar replacement or rail replacement;*
- (2) Any work that adversely affects the lateral or vertical stability of the track with the exception of spot tamping an isolated condition where not more than 15 lineal feet of track are involved at any one time and the ambient air temperature is not above 95 degrees Fahrenheit; and*
- (3) Removal and replacement of the rail fastenings on more than one tie at a time within 15 feet.*

**Guidance:** The term “restoration and renewal” in this section does not have the same meaning as in the context of § 213.11, restoration or renewal of track under traffic

conditions, in the low speed standards. The essential difference between this section and § 213.11 is that the options for a qualified person to authorize movements over a work area at a speed determined by that person are severely restricted. Under § 213.11, a qualified person may determine that it is safe to permit a train to pass through a work area at any speed up to the permanent speed on the track. Under § 213.309, these options are further limited because of the potential for human error and the speeds involved. Options available in the lower classes, for a designated person to perform general restorations under traffic and set train speeds, are not available under this section. Any restoration under traffic conditions beyond the replacement of worn, broken or missing components or fastenings or minor levels of spot surfacing is prohibited or a speed restriction must be imposed to place the track below Class 6 where the requirements for track classes 1 through 5 apply. The section does not limit any restoration work while the track is “out-of-service” and then restored to service.

This section addresses two elements of concern: 1) that the stability of the track structure is significantly degraded; and 2) that roadway worker safety is compromised.

#### Defect Codes

0309A	Reserved
0309B1	Work performed during a period of restoration and renewal under traffic conditions which interrupts rail continuity.
0309B2	Work performed during a period of restoration and renewal under traffic conditions which adversely affects track stability.
0309B3	Removal and replacement of the rail fastenings on more than one tie at a time within 15 feet during a period of restoration and renewal under traffic conditions.

#### § 213.311 *Measuring track not under load*

*When unloaded track is measured to determine compliance with requirements of this subpart, evidence of rail movement, if any, that occurs while the track is loaded shall be added to the measurements of the unloaded track.*

**Guidance:** In addition to the static (unloaded) geometry measurements taken, the amount of visually detectable dynamic (loaded) deflection that occurs under train movement must be considered. This includes the amount of vertical or lateral rail deflection occurring between rail base and tie plate, a tie plate and crosstie, from voids between the crosstie and ballast section resulting from elastic compression, or any combinations of the above must be added. Each deflection under the running rails must be measured and properly considered when computing the collective deviations under a load. It is very important that consideration be given to both rails when measuring these deflections. The following figure illustrates this concept in relation to lateral rail movement in a tie plate.



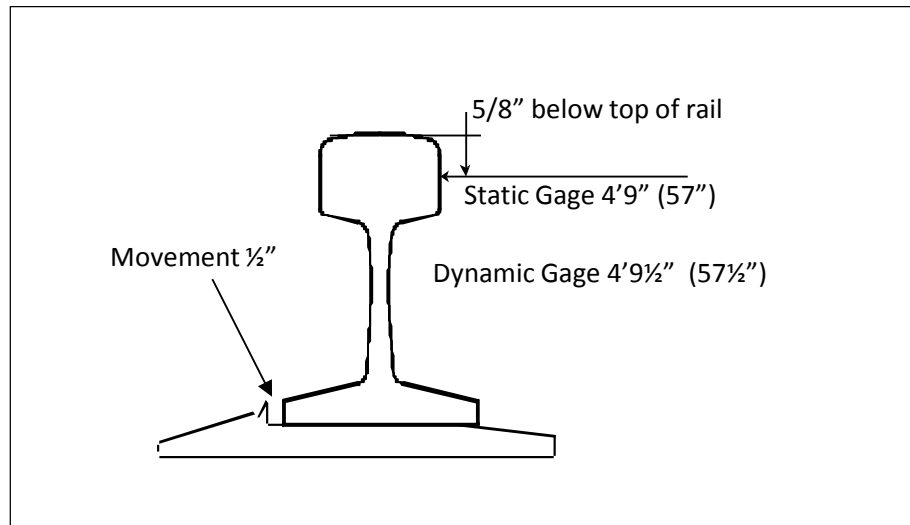

Vertical and lateral deflections may be found at locations such as rail joints and turnout locations with poor wooden cross-ties and conventional cut-spike fastening conditions; at bridge abutments and over culverts where the subgrade has settled; or where incipient geometry conditions exist. The word “incipient” means “beginning to appear.”

**§ 213.313 Application of requirements to curved track.**

*Unless otherwise provided in this part, requirements specified for curved track apply only to track having a curvature greater than 0.25 degree.*

**Guidance:** This section states that, unless otherwise provided in this part, requirements specified for curved track apply only to track having a curvature greater than 0.25 degree. This definition is intended to apply to all sections where limits for curved track are specified, unless otherwise provided.

For curves with a curvature equal or less than 0.25 degrees, for which requirements for curved track do not apply, the requirements for tangent track will apply. However, when determining compliance with cant deficiency and maximum allowable operating speed, these curves may still need to be treated as curves.

**§ 213.317 Waivers**

*317(a) Any owner of track to which this subpart applies may petition the Federal Railroad Administrator for a waiver from any or all requirements prescribed in this subpart.*

**Guidance:** Inspectors have no authority to grant waivers from the TSS.

*317(b) Each petition for a waiver under this section shall be filed in the manner and contain the information required by §§ 211.7 and 211.9 of this chapter.*

**Guidance:** Per 49 CFR 211.7(b) and 211.45(f), any petition for waiver must be filed by the owner or designated operator with the Docket Clerk, Office of Chief Counsel, in Washington, D.C. The petition can also be filed by a trade association, such as

Association of American Railroads (AAR), on behalf of its members. In addition to this chapter, inspectors should also reference the FRA Office of Railroad Safety's General Manual, Chapter 5 Complaint and Waiver Investigations, for guidance and information regarding waiver procedures.

General Manual, Chapter 5 (page 153) indicates that waiver petitions may also be addressed to a FRA manager or specialist. In the past, most petitions have been addressed to the chairperson of the FRA Railroad Safety Board, a position held by the Associate Administrator for Railroad Safety/Chief Safety Officer, as most waivers are decided by the board.

*317(c) If the Administrator finds that a waiver is in the public interest and is consistent with railroad safety, the Administrator may grant the waiver subject to any conditions the Administrator deems necessary. Where a waiver is granted, the Administrator publishes a notice containing the reasons for granting the waiver.*

**Guidance:** Typically, waivers bear the signature of AA/Chief Safety Officer, or his/her delegate. Inspectors should keep updated with any waivers in effect in their assigned territory which are relevant to their job activities.

#### **§ 213.319 Drainage**

*Each drainage or other water-carrying facility under, or immediately adjacent to, the roadbed must be maintained and kept free of obstruction, to accommodate expected water flow for the area concerned.*

**Guidance:** One of the most essential element of track maintenance is a comprehensive drainage system. Drainage facilities (bridges, trestles or culverts) must be given careful, detailed consideration. Drainage facilities must be examined during inspections. Openings under the track are used to channel and divert water from one side of the roadbed to the other.

The TSS specifies that each drainage structure is maintained and the inspector should observe conditions that would affect the integrity of the structure such as culvert pull-apart or separations, crushing or uneven settlement due to failure of or lack of head walls, coupled with frost action, too steep a gradient, and insufficient support.

Drainage openings must also be inspected and notice given where debris has accumulated to such an extent that expected water flow cannot be accommodated.

Most railroad drainage structures have existed for many years, and if properly maintained and kept free of debris, they are considered to be adequately designed to accommodate expected water flow even though recent high water marks may be slightly above the inlet opening.

Culverts designed with submerged inlets are common. Where questions are raised concerning the adequacy of drainage structures, the track specialist should be consulted.

The inspector must take note of the conditions of:

- Right-of-way ditches;

- Culvert, trestles and bridge inlets;
- Water carrying structures or passageways;
- Outlets or tail ditches;
- Berm ditches;
- Scouring of embankments, piling or piers in channels or at abutments;
- Filling in of passageways from silting, sand wash, or debris.

Inspectors must call to the attention of the track owner any drainage condition deemed hazardous or potentially hazardous to the safety of train operations over the track and subgrade.

**Defect Codes**

0319	Drainage or water-carrying facility not maintained.
0319	Drainage or water-carrying facility obstructed by debris.
0319	Drainage or water-carrying facility collapsed.
0319	Drainage or water-carrying facility obstructed by vegetation.
0319	Drainage or water-carrying facility obstructed by silting.
0319	Drainage or water-carrying facility deteriorated to allow subgrade saturation.
0319	Uncontrolled water undercutting track structure or embankment.

**§ 213.321 Vegetation**

*Vegetation on railroad property which is on or immediately adjacent to roadbed shall be controlled so that it does not --*

*321(a) Become a fire hazard to track-carrying structures;*

*321(b) Obstruct visibility of railroad signs and signals:*

*(1) Along the right of way, and*

*(2) At highway-rail crossings;*

*321(c) Interfere with railroad employees performing normal trackside duties;*

*321(d) Prevent proper functioning of signal and communication lines; or*

*321(e) Prevent railroad employees from visually inspecting moving equipment from their normal duty stations.*

**Guidance:** Inspectors must be aware that live and dead growth, drift, tumbleweeds, debris, etc., can constitute fire hazards to timber bridges, trestles, wooden box culverts, and other track-carrying structures.

Obstruction of the visibility of railroad signs and signals by vegetation is a deviation from the TSS. Although all signals are important, the visibility of certain signals must be closely observed: i.e., block signals, interlocking signals, speed signs (or other signs affecting the movement of trains), close clearance signs, whistle posts, and mileposts.

Paragraph (b) includes a requirement to clear vegetation from signs and signals along railroad rights-of-way and at highway-rail grade crossings. Because the scope of Part 213 limits vegetation requirements to railroad property, this is not intended to be an attempt to

dictate standards for surrounding landowners. This paragraph intends only to cover the clearing of vegetation at highway-rail grade crossings on railroad property to provide adequate visibility to the traveling public of railroad signs and signals. It is not intended to cover or preempt State or local requirements for the clearing of vegetation on railroad rights-of-way at highway-rail grade crossings.

Judgment must be exercised by the inspector in determining whether trackside vegetation will interfere with the railroad employees' performance of normal trackside duties. Weeds covering the track that hinder the ability of an inspector to see track structure components is not necessarily a noncomplying condition.

Before citing the railroad for vegetation interfering with signal or communication lines, the inspector must confirm that the line is active. Occasionally, however, inspectors may observe vegetation in lines that appear to be no longer functioning. Communication between the Track inspector and the FRA Signal and Train Control inspector is necessary if the railroad representative cannot confirm the status of a signal or communication line. When interfering with active lines, vegetation may cause false signal indications and/or disrupt communications that are vital to safe train operations. When there are questions with regard to vegetation and the signal lines, joint inspections by track and signal personnel are encouraged. Violation reports, if necessary, will be executed by the Track inspector with concurrence of the Signal inspector.

Judgment must be exercised by the inspector in determining whether or not vegetation will prevent railroad employees from visually inspecting rolling stock from their normal duty stations.

#### Defect Codes

0321A	Combustible vegetation around track-carrying structures.
0321B1	Vegetation obstructs visibility of railroad signs and fixed signals.
0321B2	Vegetation obstructs visibility of grade crossing warning signs and signals by the traveling public.
0321C1	Vegetation obstructs passing of day and night signals by railroad employees.
0321C2	Vegetation interferes with railroad employees performing normal trackside duties.
0321C3	Excessive vegetation in towpaths and around switches where employees are performing normal trackside duties.
0321C4	Vegetation brushing sides of rolling stock that prevents employees from visually inspecting moving equipment from their normal duty stations.
0321D	Vegetation prevents proper functioning of signal and/or communication lines.
0321E1	Excessive vegetation at train order office, depot, interlocking plant, a carman's building, etc., prevents employees on duty from visually inspecting moving equipment when their duties so require.
0321E2	Excessive vegetation at train meeting points prevents proper inspection by railroad employees of moving equipment.

**§ 213.323 Track gage**

323(a) Gage is measured between the heads of the rails at right-angles to the rails in a plane five-eighths of an inch below the top of the rail head.

323(b) Gage shall be within the limits prescribed in the following table:

Class of track	The gage must be at least	But not more than	The change of gage within 31 feet must not be greater than
6	4' 8"	4' 9 $\frac{1}{4}$ "	$\frac{3}{4}$ "
7	4' 8"	4' 9 $\frac{1}{4}$ "	$\frac{1}{2}$ "
8	4' 8"	4' 9 $\frac{1}{4}$ "	$\frac{1}{2}$ "
9	4' 8 $\frac{1}{4}$ "	4' 9 $\frac{1}{4}$ "	$\frac{1}{2}$ "

**Guidance:** This rule established the minimum and maximum limits for gage, and the variation in gage differs with the authorized speed. An abrupt change in gage can produce significant wheel forces at high speeds. The minimum and maximum limits for gage values, Classes 6, 7, 8, and 9, were set to minimize the onset of truck hunting.

Inspectors will make measurements at sufficient intervals to assure that track is being maintained within the prescribed limits.

Particular attention will be given to gage in turnouts or where high lateral train forces would be expected.

Gage should be measured where line or surface irregularities are observed by the inspector. Remember to observe evidence of lateral rail movement.

An accurate standard track gage or a ruler graduated in inches is an acceptable measuring device. Gage not within the specified limits of the TSS is a defect.

FRA inspectors may use a Portable Track Loading Fixture (PTLF) described in § 213.110 for the purposes of measuring loaded gage.

**Defect Codes**

0323B1	Gage dimension exceeds allowable on tangent track.
0323B2	Gage dimension is less than allowable on tangent track.
0323B3	Gage dimension exceeds allowable on curved track.
0323B4	Gage dimension is less than allowable on curved track.
0323B5	Gage variation within 31 feet exceeds allowable.

**§ 213.327 Track Alinement**

327(a) Uniformity at any point along the track is established by averaging the measured mid-chord offset values for nine consecutive points centered around that point and spaced according to the following table:

Chord Length	Spacing
--------------	---------

31'	7' 9"
62'	15' 6"
124'	31' 0"

**Guidance:** (Reference is made to the guidance for 213.57). Uniformity at any point along the track is established by averaging the measured mid-chord offset (MCO) values for nine consecutive points centered around that point, and which are spaced according to the table in this section. For example, to establish uniformity for the 31-foot chord the inspector should mark the point of concern plus four stations in each direction for a total of nine stations. Stations for the 31-foot chord are set at 7-foot 9 inch intervals. The MCO values are then obtained at each station and averaged. It is difficult to determine compliance with the 124-foot chord in the field using conventional manual methods. The method of determining uniformity is determined in this manner for tangents, spirals, and curves. The following figure illustrates the method to determine uniformity for the 31-foot chord measurement.

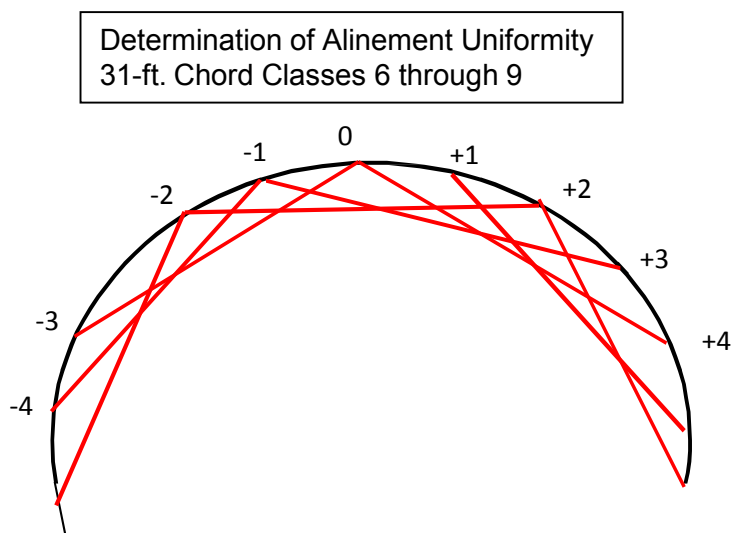

327(b) Except as provided in paragraph (c) of this section, a single alinement deviation from uniformity may not be more than the amount prescribed in the following table:

Class of track	Tangent/ Curved track	The deviation from uniformity of the mid-chord offset for a 31-foot chord may not be more than— (inches)	The deviation from uniformity of the mid-chord offset for a 62-foot chord may not be more than— (inches)	The deviation from uniformity of the mid-chord offset for a 124-foot chord may not be more than— (inches)
Class 6 track	Tangent	½	¾	1 ½
	Curved	½	⅝	1 ½
Class 7 track	Tangent	½	¾	1 ¼
	Curved	½	½	1 ¼

Class 8 track	Tangent	$\frac{1}{2}$	$\frac{3}{4}$	1
	Curved	$\frac{1}{2}$	$\frac{1}{2}$	$\frac{3}{4}$
Class 9 track	Tangent	$\frac{1}{2}$	$\frac{1}{2}$	$\frac{3}{4}$
	Curved	$\frac{1}{2}$	$\frac{1}{2}$	$\frac{3}{4}$

**Guidance:** Paragraph (b) contains the single-deviation track alignment limits for tangent and curved track. These limits reflect some revisions of this paragraph in the October, 2013 release of 49 CFR Part 213.

In some cases, particularly for repeating noncomplying alignment anomalies specified in paragraph (c), the alignment condition may be difficult to locate without the aid of a qualified geometry car. However, inspectors have the responsibility to identify noncomplying geometry conditions whenever possible. Whether located through visual or automated means, the condition must be field verified using conventional methods. Inspectors must be aware that, in addition to the geometry car, other automated inspections will identify geometry anomalies that contribute to degraded vehicle/track interaction.

Maximum limits are established for alignment for track in Classes 6 through 9, tangent and curved track (including spirals), as measured with three chords, 31-foot, 61-foot and 124-foot. An alignment deviation may be present for any one or more of the chords. If an anomaly of uniformity exists for more than one chord, it shall be reported as a single defect line with a note describing other deviations in noncompliance with another chord. For example, “5/8-inch deviation from uniformity for a 31-foot chord. Note: defect is also a 3/4-inch deviation from uniformity for a 62-foot chord.”

The point of greatest alignment deviation can usually be detected visually and marked as the point where mid-offset will be required. However, inspectors should use the locations identified by the automated inspection methods whenever possible to identify the location of deviation, and then visually verify the location.

For curves in Classes 6 through 9, an alignment condition may be in noncompliance with either the maximum limits for the 31-foot chord, or the 62-foot chord, or the 124-foot chord. As shown in the following figure, certain alignment defects may be “blind” to some chords and “visible” to others. For example, the 31-foot chord is particularly necessary for the determination of short alignment deviations, and the 124-foot chord is useful for locating long wavelengths.

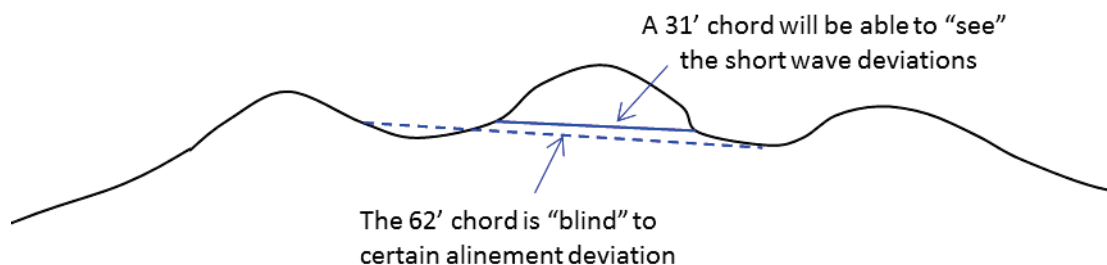

The line will be held taut against the rail 5/8-inch below the rail head, using offset blocks if necessary as for the 62' MCO in the above figure. Methods establishing a line with laser or similar methods may also be used.

*327(c) For operations at a qualified cant deficiency,  $E_u$ , of more than 5 inches, a single alinement deviation from uniformity of the outside rail of the curve may not be more than the amount prescribed in the following table:*

<b>Class of track</b>	<b>Track type</b>	<b>The deviation from uniformity of the mid-chord offset for a 31-foot chord may not be more than—(inches)</b>	<b>The deviation from uniformity of the mid-chord offset for a 62-foot chord may not be more than—(inches)</b>	<b>The deviation from uniformity of the mid-chord offset for a 124-foot chord may not be more than—(inches)</b>
Class 6 track	Curved	$\frac{1}{2}$	$\frac{5}{8}$	$1\frac{1}{4}$
Class 7 track	Curved	$\frac{1}{2}$	$\frac{1}{2}$	1
Class 8 track	Curved	$\frac{1}{2}$	$\frac{1}{2}$	$\frac{3}{4}$
Class 9 track	Curved	$\frac{1}{2}$	$\frac{1}{2}$	$\frac{3}{4}$

**Guidance:** This paragraph contains tighter, single-deviation geometry limits for operations above 5 inches of cant deficiency. These include 31-foot, 62-foot, and 124-foot MCO limits. These track geometry limits are introduced in the October 2103 release of 49 CFR Part 213, which is necessary to provide an equivalent margin of safety for operations at higher cant deficiency. The track geometry limits in this paragraph are based on the results of simulation studies to determine the safe amplitudes of track geometry alinement variations.

Guidance for paragraph (b) also applies to this paragraph. However, the limits in the table of this paragraph applies only to operations at a qualified cant deficiency of more than 5 inches, and to outside rail of the curve. For operations involving more than 5 inches of cant deficiency, the track owner or railroad must have the necessary FRA approval or documentation showing that the operations are qualified for a cant deficiency higher than 5 inches.

If the track owner or railroad, in response to an alignment exception to table (c), has posted a speed restriction which no longer corresponds to a cant deficiency of more than 5 inches, the inspector should use the limits in table (b) to assess alignment compliance.

*327(d) For three or more non-overlapping deviations from uniformity in track alinement occurring within a distance equal to five times the specified chord length, each of which exceeds the limits in the following table, each track owner shall maintain the alinement of the track within the limits prescribed for each deviation:*



<i>Class of track</i>	<i>The deviation from uniformity of the mid-chord offset for a 31-foot chord may not be more than (inches)</i>	<i>The deviation from uniformity of the mid-chord offset for a 62-foot chord may not be more than (inches)</i>	<i>The deviation from uniformity of the mid-chord offset for a 124-foot chord may not be more than (inches)</i>
<i>Class 6 track</i>	$\frac{3}{8}$	$\frac{1}{2}$	1
<i>Class 7 track</i>	$\frac{3}{8}$	$\frac{3}{8}$	$\frac{7}{8}$
<i>Class 8 track</i>	$\frac{3}{8}$	$\frac{3}{8}$	$\frac{1}{2}$
<i>Class 9 track</i>	$\frac{3}{8}$	$\frac{3}{8}$	$\frac{1}{2}$

**Guidance:** Paragraph (d) establishes alinement requirements for repeated deviations (three or more non-overlapping deviations) which occur within a distance equal to five times the specified chord length. Each occurrence of three or more deviations within a distance of five times the chord length, each of which exceeds the limit in the table, is considered one defective condition.

Repeated alinement deviations may excite a vehicle’s natural resonance and cause adverse vehicle reaction. Although repeated alinement deviations are rare they are usually identified by automated inspections. However, the inspector must be aware of their significance.

Repeated alinement defects are specific to one rail at a time. If an inspector believes that a geometry condition on the opposite rail within the same area may contribute to the excitation, the inspector should inform the railroad representative and note the condition on the inspection report.

The term “non-overlapping” is a common term but clarifies the concept in relation to track geometry inspection vehicles. Within one alinement “swing,” normally several midchord offset measurements will exceed the specified threshold. However, for an alinement deviation to be considered as a repeating defect, the chords themselves must not overlap. The following figure illustrates three repeating alinement deviations. The concept is that one “swing” is not counted more than once.

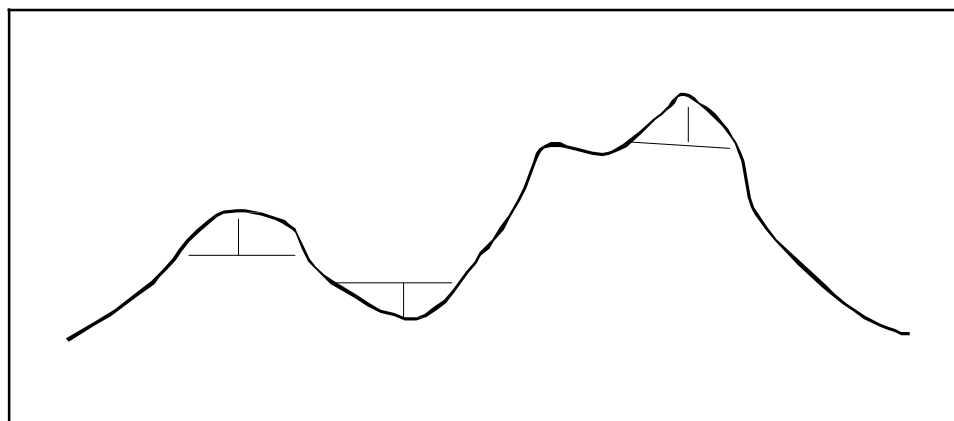

Multiple alinement deviations may excite harmonic motion in the vehicle. Multiple deviations are three or more non-overlapping deviations from uniformity in track profile occurring within a distance equal to five times the specified chord length. The repeated condition, not each alinement deviation, is considered one defect. However, in the rare case where deviations repeat beyond the distance of five times the specified chord length, the inspector shall consider all the sets of deviations as one exception. However, the total length the repeating condition occurs in feet must be reported along with the number of repeating deviations and the magnitude of each deviation.

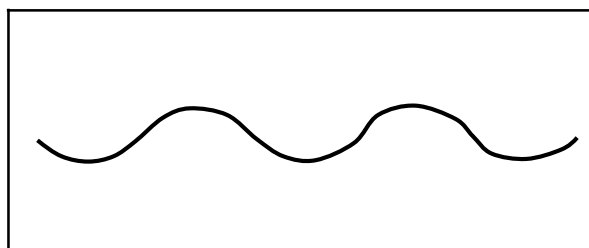

### Defect Codes

0327B1	The alinement of track exceeds the allowable deviation for a 31-foot chord for a single deviation.
0327B2	The alinement of track exceeds the allowable deviation for a 62-foot chord for a single deviation.
0327B3	The alinement of track exceeds the allowable deviation for a 124-foot chord for a single deviation.
0327C1	The alinement of track exceeds the allowable deviation for a 31-foot chord a single deviation on curve with $E_u, > 5$ inches
0327C2	The alinement of track exceeds the allowable deviation for a 62-foot chord for a single deviation on curve with $E_u, > 5$ inches..
0327C3	The alinement of track exceeds the allowable deviation for a 124-foot chord for a single deviation on curve with $E_u, > 5$ inches.
0327D1	The alinement of track exceeds the allowable deviation for a 31-foot chord for three or more deviations.
0327D2	The alinement of track exceeds the allowable deviation for a 62-foot chord for three or more deviations.
0327D3	The alinement of track exceeds the allowable deviation for a 124-foot chord for three or more deviations.

### § 213.329 Curves, elevation and speed limitations

329(a) *The maximum elevation of the outside rail of a curve may not be more than 7 inches. The outside rail of a curve may not be lower than the inside rail by design, except when engineered to address specific track or operating conditions; the limits in § 213.331 apply in all cases.*

**Guidance:** Paragraph (a) does not imply that more than 6 inches of superelevation is recommended in a curve; rather the paragraph limits the amount of crosslevel in a curve to

control the unloading of the wheels on the high rail, especially at low speeds. The crosslevel limits notwithstanding, this standard establishes the maximum crosslevel at any point on the curve which may not be more than 7 inches. In curves, crosslevel is measured by subtracting the relative difference in height between the top surface (tread) of the inside (low) rail from the tread of the outside (high) rail.

The Associate Administrator for Railroad Safety/Chief Safety Officer shall reach a decision regarding the railroad's request for approval of a level of cant deficiency for specific equipment types based on the staff's review of the engineering information submitted by the railroad. When requested by Headquarters and regional track specialists, the inspector may be asked to provide a memorandum containing recommendations concerning the railroad's request.

In the 1998 rule, the provision had been stated in terms of the maximum crosslevel of the outside rail, with the same limits. As crosslevel is a function of elevation differences between two rails, and is specifically addressed by provisions in § 213.331, this paragraph is intended to focus the provision on the maximum allowable elevation of a single rail.

The phrase "*except when engineered to address specific track or operating conditions*" is intended to address special cases, such as a turnout that comes off the high rail in a curve, to allow reverse elevation to be designed into the curve out of necessity and for safety reasons.

*329(b) The maximum allowable posted timetable operating speed for each curve is determined by the following formula—*

$$V_{\max} = \sqrt{\frac{E_a + E_u}{0.0007D}}$$

*Where*

*V<sub>max</sub> = Maximum allowable posted timetable operating speed (m.p.h.).*

*E<sub>a</sub> = Actual elevation of the outside rail (inches).<sup>6</sup>*

*E<sub>u</sub> = Qualified cant deficiency<sup>7</sup> (inches) of the vehicle type.*

*D = Degree of curvature (degrees).<sup>8</sup>*

**Guidance:** Several combinations of curvature and elevation resulting in speed limitations may exist and should be considered throughout the curve when determining compliance with this section.

The designation of  $V_{\max}$  has been changed from "maximum allowable operating speed" in the 1998 rule to "maximum allowable posted timetable operating speed." The track

<sup>6</sup> Actual elevation,  $E_a$ , for each 155-foot track segment in the body of the curve is determined by averaging the elevation for 11 points through the segment at 15.5-foot spacing. If the curve length is less than 155 feet, the points are averaged through the full length of the body of the curve.

<sup>7</sup> If the actual elevation,  $E_a$ , and degree of curvature,  $D$ , change as a result of track degradation, then the actual cant deficiency for the maximum allowable posted timetable operating speed,  $V_{\max}$ , may be greater than the qualified cant deficiency,  $E_u$ . This actual cant deficiency for each curve may not exceed the qualified cant deficiency,  $E_u$ , plus one-half inch.

<sup>8</sup> Degree of curvature,  $D$ , is determined by averaging the degree of curvature over the same track segment as the elevation.

owners/railroads can use it to establish the “posted timetable operating speed” based on the qualified cant deficiency ( $E_u$ ) and the design values of elevation ( $E_a$ ) and curvature ( $D$ ). The  $V_{max}$  value will then be the target or reference speed. Track inspectors can use the formula to assess compliance in two ways:

1. Calculating maximum allowable speed by inserting the elevation ( $E_a$ ), curvature ( $D$ ) at the time of inspection, and the qualified cant deficiency ( $E_u$ ). If the resulting speed is lower than the reference speed, there is potentially a limiting speed defect.
2. Calculating cant deficiency by inserting the reference  $V_{max}$ , elevation ( $E_a$ ), and curvature ( $D$ ) at the time of inspection. If the resulting actual cant deficiency is higher than the qualified cant deficiency, there is potentially a limiting speed defect.

$$E_u = V_{max}^2 \cdot 0.0007D - E_a$$

Speed becomes more critical if surface conditions have deteriorated or curvature has increased due to misalignment near the point of limiting speed and inspectors need to determine compliance with the surface standard in § 213.331 or the alignment standard in § 213.327, which in some cases will be more restrictive.

Curves may exist by design or introduced as a result of maintenance or geometry degradation. In either case, lack of superelevation will cause trains to experience an unbalanced condition. The deviations from uniform profile and uniform alignment, as outlined in §§ 213.331 and 213.327, will not preclude longer wavelength misalignments on the order of 200 feet or greater that resemble the characteristics of a curve from being treated as curves for which the unbalance formula defined in this section will be applied.

Footnote 6 establishes that the actual elevation,  $E_a$ , for each 155-foot track segment in the body of the curve is determined by averaging the elevation for 11 points through the segment at 15.5-foot spacing. In calculating elevation, 10 measurements are taken from the point of concern—5 on each side—so that 11 points are actually averaged, which includes the point of concern. The  $V_{max}$  equation is intended to be applied in the body of the curve, and the actual elevation and degree of curvature are determined using the averaging technique defined in the Footnote 6. Within spirals, where the degree of curvature and elevation are changing continuously, local deviations from uniform elevation and degree of curvature are governed by the limits in § 213.327 and § 213.331.

Footnote 7 permits the vehicle type to operate at the cant deficiency for which it is approved,  $E_u$ , plus ½ inch, if the actual elevation of the outside rail,  $E_a$ , and the degree of track curvature,  $D$ , change as a result of track degradation. The note is intended to provide a tolerance to account for the effects of local crosslevel or curvature conditions on  $V_{max}$  that may result in the actual cant deficiency exceeding the cant deficiency approved for the equipment. The intent is to allow this tolerance for “local crosslevel or curvature conditions” that result in track degradation below the maintenance limits of the track owner/railroad. The footnote is not intended to provide a tolerance to be factored into the maintenance limits. For example, if the “maximum allowable posted timetable operating speed” is based on a  $V_{max}$  corresponding to 3 inches of cant deficiency, the track owner/railroad cannot establish maintenance practices that are intended to result in operation of equipment at a speed that produces up to 3.5 inches of cant deficiency. Yet, in this example, should the equipment actually operate at a speed that produces over 3 inches of cant deficiency due to track degrading below the intended maintenance limits of

the track owner/railroad, the track owner/railroad should not be penalized merely because the cant deficiency exceeds 3 inches (see below for additional guidance).

The limiting speed defect can range from a few feet to the entire curve length. Therefore, the defect length alone cannot determine whether the limiting speed defect arose from track degradation or from the failure to carry out appropriate track maintenance.

As noted above, footnote 7 provides that if the actual elevation and degree of curvature change as a result of track degradation, the actual amount of cant deficiency in a curve may be greater than the approved amount of cant deficiency,  $E_u$ , but not by more than  $\frac{1}{2}$  additional inch. This footnote is consistent with FRA's enforcement practice – namely, to provide a tolerance for limited exceedances of the approved amount of cant deficiency,  $E_u$ , in curves. Because a tolerance is now part of the regulation, not all exceedances are actual defects (instances of noncompliance). The inspector should only record the condition as a defect if there is evidence that the maintenance practices of the track owner/railroad created a condition where the actual amount of cant deficiency exceeded the approved value. In such case, FRA expects the track owner/railroad to take appropriate remedial actions. The inspector should consider writing a recommendation for civil penalty if the level of cant deficiency based on the maximum speed, elevation, and curvature exceeds the approved value,  $E_u$ , by more than 0.5 inch. When the actual cant deficiency is found to exceed the approved level, there are many scenarios that could involve compliance or noncompliance with the regulation, and all of these different scenarios cannot be easily described here. The inspector should consider multiple factors when determining whether to assess a defect or recommend a violation. For example, if the inspector can establish that a track has been recently machine-tamped and that it was not possible for the track to have degraded to the level of causing an exceedance of the approved cant deficiency in the time period after the tamping, the inspector may assess a defect. In another example, if the track owner/railroad voluntarily performs spot maintenance on a curve, typically by spot-tamping, to bring the curve to uniformity (in terms of curvature and elevation), and the amount of cant deficiency still exceeds the approved level by a nominal amount, the inspector should exercise his or her discretion whether to assess a defect. The inspector should consider assessing a defect when the exceedance is close to the maximum tolerance, which leaves little room for further track degradation. In all cases, if the inspector cannot determine whether a condition is out of compliance, or whether to assess a defect or recommend a civil penalty, he or she should consult with the regional track specialist.

*329(c) All vehicles are considered qualified for operating on track with a cant deficiency,  $E_u$ , not exceeding 3 inches. Table 1 of appendix A to this part is a table of speeds computed in accordance with the formula in paragraph (b) of this section, when  $E_u$  equals 3 inches, for various elevations and degrees of curvature.*

**Guidance:** This paragraph provides that all vehicle types are considered qualified for up to 3 inches of cant deficiency, as allowed since the 1998 Track Safety Standards final rule.

*329(d) Each vehicle type must be approved by FRA to operate on track with a qualified cant deficiency,  $E_u$ , greater than 3 inches. Each vehicle type must demonstrate, in a ready-for-service load condition, compliance with the requirements of either paragraph (d)(1) or (2) of this section.*

- (1) *When positioned on a track with a uniform superelevation equal to the proposed cant deficiency:*
  - (i) *No wheel of the vehicle type unloads to a value less than 60 percent of its static value on perfectly level track; and*
  - (ii) *For passenger cars, the roll angle between the floor of the equipment and the horizontal does not exceed 8.6 degrees; or*
- (2) *When operating through a constant radius curve at a constant speed corresponding to the proposed cant deficiency, and a test plan is submitted to and approved by FRA in accordance with § 213.345(e) and (f):*
  - (i) *The steady-state (average) load on any wheel, throughout the body of the curve, is not less than 60 percent of its static value on perfectly level track; and*
  - (ii) *For passenger cars, the steady-state (average) lateral acceleration measured on the floor of the carbody does not exceed 0.15g.*

**Guidance:**

The paragraph specifies the requirements for vehicle qualification over track with more than 3 inches of cant deficiency in Track Classes 6 through 9. The requirements, consistent with the standards in § 213.57 (for lower-speed track classes), limit both the vertical wheel load remaining on the raised wheels to no less than 60 percent of their static level values and carbody roll for passenger cars to no more than 8.6 degrees, with respect to the horizontal, when the vehicle is standing (stationary) on track with a uniform superelevation equal to the proposed cant deficiency.

The requirements in this paragraph may be met by either static or dynamic testing (consistent with the requirements in § 213.57). As in § 213.57, the vehicle type must be tested in a ready-for-service condition, i.e., in the same vehicle/track performance condition in which it would be in passenger service. For example, the vehicle type may or may not be loaded to simulate passengers on board, and this information would be necessary for a complete evaluation of the vehicle's performance.

Static lean test is a means to evaluate the basic vehicle performance in curves. The test serves as an indicator of the behavior of the vehicle suspension components. The car or locomotive is placed so that the entire vehicle stands on a track with one rail uniformly higher than the other, causing the vehicle to lean toward the lower rail. The vehicle's response to this situation is determined by its weight distribution and by the presence of free play and the stiffness of its overall suspension system. As required, the static lean test limits the vertical wheel load remaining on the raised wheels to no less than 60 percent of their static level values and limits the roll of a passenger carbody to 8.6 degrees with respect to the horizontal, when the vehicle is standing on track with superelevation equal to the proposed cant deficiency. These requirements prevent a "top-heavy" vehicle or a vehicle with a high center of gravity, and a very flexible (soft) suspension system from leaning excessively.

The dynamic test limits the steady-state vertical wheel load remaining on the low rail wheels to no less than 60 percent of their static level values and limits the lateral acceleration in a passenger car to 0.15g steady-state, when the vehicle operates through a curve at the proposed cant deficiency. This 0.15g steady-state lateral acceleration limit in the dynamic test is consistent with the 8.6-degree roll limit in the static lean test, in that it corresponds to the lateral acceleration that a passenger would experience in a standing (stationary) vehicle whose carbody is at a roll angle of 8.6 degrees with respect to the horizontal.

Measurements and supplemental research have indicated that a steady-state, carbody lateral acceleration limit of 0.15g is considered to be the maximum. If the steady-state lateral acceleration exceeds this level, jolts from vehicle dynamic response to track deviations can present a hazard to passenger safety. While other FRA vehicle/track interaction safety criteria principally address external safety hazards that may cause a derailment, such as damage to track structure and other conditions at the wheel/rail interface, the steady-state, carbody lateral acceleration limit specifically addresses the safety of the interior occupant environment. This steady-state carbody lateral acceleration will result in a lateral force, pulling passengers to one side of the carbody. It is not the same as sustained, carbody lateral oscillatory accelerations, or continuous side-to-side oscillations (hunting) of the carbody in response to track conditions, which could exist on both curved and tangent track.

The less stringent steady-state, carbody lateral acceleration limit and carbody roll angle limit adopted in the current rule (effective July 11, 2013) will minimize both the need to equip vehicles with tilt systems at higher cant deficiencies and the costs associated with such features. Moreover, by facilitating higher cant deficiency operations, savings may also result from shortened trip times. These savings may be particularly beneficial to passenger operations in emerging high-speed rail corridors, enabling faster operations through curves.

So that such savings will not compromise safety, FRA has adopted additional track geometry requirements for operations above 5 inches of cant deficiency, whether or not the vehicles are equipped with tilt systems. These additional track geometry requirements were developed to control undesirable vehicle response to track conditions that could pose derailment risk.

*329(e) The track owner or railroad shall transmit the results of the testing specified in paragraph (d) of this section to FRA's Associate Administrator for Railroad Safety/Chief Safety Officer (FRA) requesting approval for the vehicle type to operate at the desired curving speeds allowed under the formula in paragraph (b) of this section. The request shall be made in writing and contain, at a minimum, the following information—*

- (1) A description of the vehicle type involved, including schematic diagrams of the suspension system(s) and the estimated location of the center of gravity above top of rail;*
- (2) The test procedure,<sup>9</sup> including the load condition under which the testing was performed, and description of the instrumentation used to qualify the vehicle type, as well as the maximum values for wheel unloading and roll angles or accelerations that were observed during testing; and*
- (3) For vehicle types not subject to parts 229 or 238 of this chapter, procedures or standards in effect that relate to the maintenance of all safety-critical components of the suspension system(s) for the particular vehicle type. Safety-critical components of the suspension system are those that impact or have significant influence on the roll of the carbody and the distribution of weight on the wheels.*

---

<sup>9</sup> *The test procedure may be conducted whereby all the wheels on one side (right or left) of the vehicle are raised to the proposed cant deficiency, the vertical wheel loads under each wheel are measured, and a level is used to record the angle through which the floor of the vehicle has been rotated.*

**Guidance:** This paragraph clarifies the submittal requirements to FRA to obtain approval for a vehicle type to operate at a desired cant deficiency. The requirements include the load condition under which the testing is performed and the description of the test procedure. Additional clarification in this paragraph has been included for submitting suspension system maintenance information. The requirement for submitting suspension system maintenance information applies to vehicle types not subject to 49 CFR parts 238 or 229, such as a freight car operated in a freight train, and then only to safety-critical components.

Footnote 9 references testing at “the proposed cant deficiency”, consistent with the requirements of this section.

*329(f) In approving the request made pursuant to paragraph (e) of this section, FRA may impose conditions necessary for safely operating at the higher curving speeds. Upon FRA approval of the request, the track owner or railroad shall notify FRA in writing no less than 30 calendar days prior to the proposed implementation of the approved higher curving speeds allowed under the formula in paragraph (b) of this section. The notification shall contain, at a minimum, identification of the track segment(s) on which the higher curving speeds are to be implemented.*

**Guidance:** The paragraph requires that a track owner/railroad notify FRA prior to the implementation of the approved higher curving speeds. The paragraph also clarifies that in approving the request made pursuant to paragraph (e), FRA may impose conditions necessary for safely operating at the higher curving speeds.

*329(g) The documents required by this section must be provided to FRA by:*

- (1) The track owner; or*
- (2) A railroad that provides service with the same vehicle type over trackage of one or more track owner(s), with the written consent of each affected track owner.*

**Guidance:** This paragraph (g) (formerly paragraph (f)) is identical to two other provisions in § 213.57(g)—the counterpart to this section for lower-speed track classes—and § 213.345(i) (see guidance for § 213.345(i)).

*329(h) (1) Vehicle types permitted by FRA to operate at cant deficiencies,  $E_u$ , greater than 3 inches but not more than 5 inches shall be considered qualified under this section to operate at those permitted cant deficiencies for any Class 6 track segment. The track owner or railroad shall notify FRA in writing no less than 30 calendar days prior to the proposed implementation of such curving speeds in accordance with paragraph (f) of this section.*

- (2) Vehicle types permitted by FRA to operate at cant deficiencies,  $E_u$ , greater than 5 inches on Class 6 track, or greater than 3 inches on Class 7 through 9 track, shall be considered qualified under this section to operate at those permitted cant deficiencies only for the previously operated or identified track segments(s). Operation of these vehicle types at such cant deficiencies and track class on any other track segment is permitted only in accordance with the qualification requirements in this subpart.*

**Guidance:** This paragraph provides “portability” by allowing vehicles already qualified to operate between 3 and 5 inches cant deficiency to operate on different track segments and by eliminating redundant testing for vehicle types that have been safely operated at the



permitted cant deficiency. The rationale for this portability is that the tests in this section, as in § 213.57 for lower-speed track classes, are not location-specific because they can be conducted at a static testing facility, and this portability of qualification for these amounts of cant deficiency can be safely allowed for Class 6 track speeds.

Nonetheless, this paragraph (f) does require that the track owner/railroad still needs to notify FRA no less than 30 calendar days prior to the proposed implementation of such curving speeds on another Class 6 track segment. This notice is intended to identify the new track segments so that FRA can ensure that appropriate permission has been provided for the proposed operation, and otherwise administer the requirements of this rule.

The provision in paragraph (h)(2) restricts the “portability” of cant deficiency qualification for vehicle types that have been permitted by FRA to operate at cant deficiencies greater than 5 inches on Class 6 track, or greater than 3 inches on Class 7 to 9 track. Operations under these conditions over different track segments must be newly qualified in accordance with this rule.

329(i) *As used in this section and in §§ 213.333 and 213.345—*

- (1) *Vehicle means a locomotive, as defined in § 229.5 of this chapter; a freight car, as defined in § 215.5 of this chapter; a passenger car, as defined in § 238.5 of this chapter; and any rail rolling equipment used in a train with either a freight car or a passenger car.*
- (2) *Vehicle type means like vehicles with variations in their physical properties, such as suspension, mass, interior arrangements, and dimensions that do not result in significant changes to their dynamic characteristics.*

**Guidance:** This paragraph clarifies “vehicle” and “vehicle type.” The paragraph is of particular importance when determining if a vehicle type is subject to the qualification requirements of this section. For example, a vehicle type with modified primary springs to improve high-speed performance may be considered a new vehicle type.

#### Defect Codes

0329A	Maximum crosslevel or reverse elevation on curve exceeds allowable.
0329B1	Operating speed exceeds allowable for 3-inches of unbalance, based on curvature and elevation.
0329C	Operating speed exceeds allowable for a FRA approved unbalance based on curvature and elevation.

### § 213.331 Track surface

331(a) *For a single deviation in track surface, each owner of the track to which this subpart applies shall maintain the surface of its track within the limits prescribed in the following table:*

Track surface (inches)	Class of track			
	6	7	8	9
<i>The deviation from uniform<sup>1</sup> profile on either rail at the mid-ordinate of a 31-foot chord may not be more than</i>	1	1	$\frac{3}{4}$	$\frac{1}{2}$

<i>The deviation from uniform profile on either rail at the mid-ordinate of a 62-foot chord may not be more than</i>	1	1	1	$\frac{3}{4}$
<i>Except as provided in paragraph (b) of this section, the deviation from uniform profile on either rail at the mid-ordinate of a 124-foot chord may not be more than</i>	$1\frac{3}{4}$	$1\frac{1}{2}$	$1\frac{1}{4}$	1
<i>The deviation from zero crosslevel at any point on tangent track may not be more than<sup>2</sup></i>	1	1	1	1
<i>Reverse elevation on curves may not be more than</i>	$\frac{1}{2}$	$\frac{1}{2}$	$\frac{1}{2}$	$\frac{1}{2}$
<i>The difference in crosslevel between any two points less than 62 feet apart may not be more than<sup>3</sup></i>	$1\frac{1}{2}$	$1\frac{1}{2}$	$1\frac{1}{4}$	1
<i>On curved track, the difference in crosslevel between any two points less than 10 feet apart (short warp) may not be more than</i>	$1\frac{1}{4}$	$1\frac{1}{8}$	1	$\frac{3}{4}$

<sup>1</sup> Uniformity for profile is established by placing the midpoint of the specified chord at the point of maximum measurement.

<sup>2</sup> If physical conditions do not permit a spiral long enough to accommodate the minimum length of runoff, part of the runoff may be on tangent track.

<sup>3</sup> However, to control harmonics on jointed track with staggered joints, the crosslevel differences shall not exceed 1 inch in all of six consecutive pairs of joints, as created by seven low joints. Track with joints staggered less than 10 feet apart shall not be considered as having staggered joints. Joints within the seven low joints outside of the regular joint spacing shall not be considered as joints for purposes of this footnote.

**Guidance:** There are changes in the rule, which became effective on July 11, 2013:

1. The 124-foot MCO limit for Class 9 track has been reduced to 1 inch, based on a review of simulation results of Acela equipment performance.
2. The limit for the difference in crosslevel between any two points less than 62 feet apart (62-foot warp) has been reduced to  $1\frac{1}{4}$  inches for Class 8 track, and 1 inch for Class 9 track. These two changes are intended to provide more consistent safety limits and are based on simulation studies conducted for short warp conditions.
3. New limits were added:
  - a. The deviation from zero crosslevel on tangent track is carried over from Class 5 track.
  - b. The  $\frac{1}{2}$ -inch reverse elevation limit for curved track was transcribed from the text formerly specified in § 213.329(a).
  - c. A new limit for the difference in crosslevel between any two points less than 10 feet apart (short warp) has been added to this paragraph.

As in alinement, deviation from uniform profile must be checked by using three chords: 31-foot, 62-foot, and 124-foot. A profile condition may be in noncompliance with any or all the chords. The measurement using all chords is required to cover the necessary wavelengths of interest that may excite undesirable vehicle responses.

Uniformity for profile is different than uniformity established for alinement. In the case of alinement, uniformity as described in § 213.327(a) is determined by averaging mid-chord offset values for nine consecutive points centered around that point. However, uniformity for profile, as described in footnote 1 below the table, is a straight line placed across the

deviation in such a manner as to measure the largest mid-ordinate. The following figure illustrates this procedure using a 62-foot chord. Depending upon the length of the profile perturbation, a particular chord may be inside or span the perturbation.

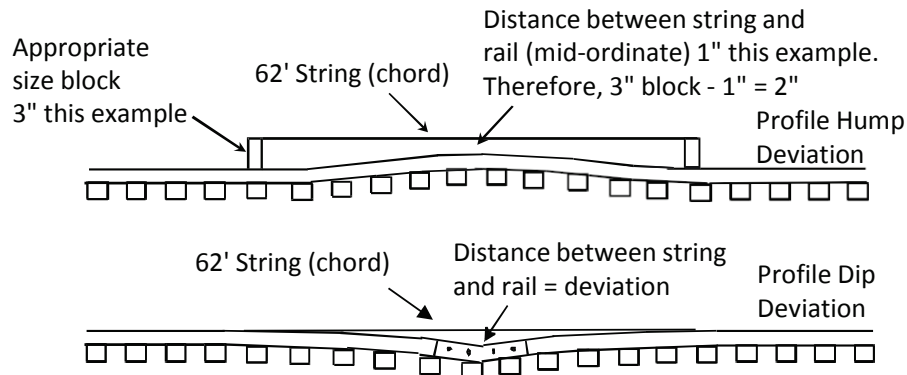

As in the standards for Classes 1 through 5, the “warp” condition is equally valid in contributing to vehicle twist and wheel climb. The difference in crosslevel between any two points less than 62 feet apart may not be more than the limit specified.

Jointed track is not typical for high-speed track. However, inspectors should check for a harmonic rock off condition whenever several joints in a row are low as indicated in footnote 2. Joint stagger that is not identical from stagger to stagger, such as in a curve or when a rail longer than the original construction is installed, shall be considered in the harmonic calculation. Additional joint(s) introduced because of the installation of short rail(s) are ignored in evaluating a harmonic condition.

Construction consisting of 79-foot or 80-foot rails does not result in harmonic rock off conditions since they occur outside of vehicle truck spacing. For 79-foot or 80-foot rails and stagger spacing less than 10 feet, this footnote is not applicable and inspectors shall review the condition for compliance with other track surface parameters. The following figure illustrates a harmonic condition.

Inspectors shall carefully apply the provisions of this footnote. An acceptable remedial action is to raise and tamp one or two joints in the middle of the consecutive low joints. This will break up the harmonics.

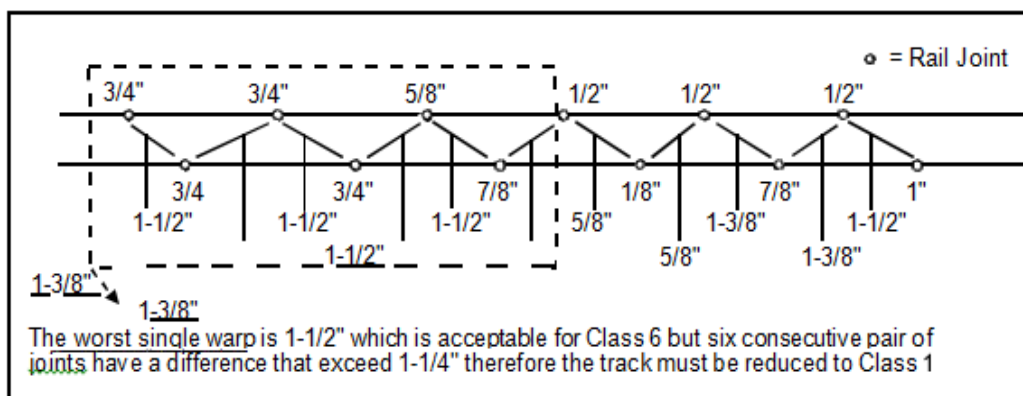

331(b) For operations at a qualified cant deficiency,  $E_u$ , of more than 5 inches, a single deviation in track surface shall be within the limits prescribed in the following table:

Track surface (inches)	Class of track			
	6	7	8	9
The difference in crosslevel between any two points less than 10 feet apart (short warp) may not be more than .....	1¼	1	1 <sup>1</sup>	¾
The deviation from uniform profile on either rail at the mid-ordinate of a 124-foot chord may not be more than .....	1½	1¼	1¼	1

<sup>1</sup> For curves with a qualified cant deficiency,  $E_u$ , of more than 7 inches, the difference in crosslevel between any two points less than 10 feet apart (short warp) may not be more than three-quarters of an inch.

**Guidance:** This paragraph contains tighter geometry limits for operations above 5 inches of cant deficiency on curves. These include tighter limits for 124-foot MCO and 10-foot warp (the difference in crosslevel between any two points less than 10 feet apart). Please note that the limits in paragraph (a) continue to apply unless they are superseded by the limits in paragraph (b). Specifically, for operations above 5 inches of cant deficiency, the limits in rows 1 to 2 and 4 through 6 in paragraph (a) are still applicable.

Further, inspectors are reminded that the trigger for the limits in this paragraph is a cant deficiency greater than 5 inches. If a geometry exception in table (b) is encountered, the railroad may lower the speed that will no longer result in a cant deficiency more than 5 inches. In this case, the limits in table (a) apply. In case the speed reduction effectively places the track into track Class 5 or even lower, the limits in 213.63 apply.

331(c) For three or more non-overlapping deviations in track surface occurring within a distance equal to five times the specified chord length, each of which exceeds the limits in the following table, each track owner shall maintain the surface of the track within the limits prescribed for each deviation:

Track surface (inches)	Class of track			
	6	7	8	9

<i>The deviation from uniform profile on either rail at the mid-ordinate of a 31-foot chord may not be more than .....</i>	$\frac{3}{4}$	$\frac{3}{4}$	$\frac{1}{2}$	$\frac{3}{8}$
<i>The deviation from uniform profile on either rail at the mid-ordinate of a 62-foot chord may not be more than .....</i>	$\frac{3}{4}$	$\frac{3}{4}$	$\frac{3}{4}$	$\frac{1}{2}$
<i>The deviation from uniform profile on either rail at the mid-ordinate of a 124-foot chord may not be more than .....</i>	$1\frac{1}{4}$	1	$\frac{7}{8}$	$\frac{5}{8}$

**Guidance:** The limits in this paragraph are intended to restrict repeating occurrences of track geometry conditions, each of which may not represent an exception as an individual event. Please note that as of July 11, 2013, the 124-ft profile MCO limit has been tightened from 7/8 inch to 5/8 inch.

Multiple profile deviations may excite harmonic motion in the vehicle. Multiple deviations are three or more non-overlapping deviations from uniformity in track profile, occurring within a distance equal to five times the specified chord length. Refer to § 213.327 for a description of “non-overlapping.” The repeated condition, not each profile deviation, is considered one defect. However, similar to alignment, in the rare case where deviations repeat beyond the distance of five times the specified chord length, the inspector shall consider all the sets of deviations as one exception. However, the total length in feet that the repeating condition occurs must be reported along with the number of repeating deviations when the magnitude of each deviation.

Repeated profile defects are specific to one rail at a time. If an inspector believes that a geometry condition on the opposite rail within the same area may contribute to the excitation, the inspector should inform the railroad representative and note the condition on the inspection report.

### Defect Codes

0331A1	The profile of track exceeds the allowable deviation for a 31-foot chord for a single deviation.
0331A2	The profile of track exceeds the allowable deviation for a 62-foot chord for a single deviation.
0331A3	The profile of track exceeds the allowable deviation for a 124-foot chord for a single deviation.
0331A4	The deviation from zero crosslevel on tangent track exceeds allowable
0331A5	Reverse elevation on curves exceeds allowable
0331A6	Difference in crosslevel between any two points less than 62-feet apart (on tangent, curves, or spirals) exceeds allowable.
0331A7	Crosslevel differences for six or more consecutive pairs of staggered joints exceeds allowable.
0331A8	Difference in crosslevel between any two points less than 10-feet apart on curves exceeds allowable.
0331B1	Difference in crosslevel between any two points less than 10-feet apart on curves exceeds allowable on curve with $E_u > 5$
0331B2	The profile of track exceeds the allowable deviation for a 124-foot chord for a single deviation on curve with $E_u > 5$ ”.

0331C1	The profile of track exceeds the allowable deviation for a 31-foot chord for three or more deviations.
0331C2	The profile of track exceeds the allowable deviation for a 62-foot chord for Three or more deviations.
0331C3	The profile of track exceeds the allowable deviation for a 124-foot chord for three or more deviations.

### § 213.332 Combined track alinement and surface deviations.

332(a) This section applies to any curved track where operations are conducted at a qualified cant deficiency,  $E_u$ , greater than 5 inches, and to all Class 9 track, either curved or tangent.

332(b) For the conditions defined in paragraph (a) of this section, the combination of alinement and surface deviations for the same chord length on the outside rail in a curve and on any of the two rails of a tangent section, as measured by a TGMS, shall comply with the following formula: On any curved track where operations are conducted at a qualified cant deficiency,  $E_u$ , greater than 5 inches, the combination of alinement and surface deviations for the same chord length on the outside rail in the curve, as measured by a TGMS, shall comply with the following formula:

$$\frac{3}{4} \times \left| \frac{A_m}{A_L} + \frac{S_m}{S_L} \right| \leq 1$$

Where—

$A_m$  = measured alinement deviation from uniformity (outward is positive, inward is negative).

$A_L$  = allowable alinement limit as per § 213.327(c) (always positive) for the class of track.

$S_m$  = measured profile deviation from uniformity (down is positive, up is negative).

$S_L$  = allowable profile limit as per § 213.331(a) and § 213.331(b) (always positive) for the class of track.

$$\left| \frac{A_m}{A_L} + \frac{S_m}{S_L} \right| = \text{the absolute (positive) value of the result of } \frac{A_m}{A_L} + \frac{S_m}{S_L}.$$

**Guidance:** This section contains limits addressing combined track alinement and surface deviations. These limits apply to high-speed operations on curved track above 5 inches of cant deficiency, as well as to any operation at Class 9 speeds.

The equation is given for computing the combined track alinement and surface deviations within a single chord length. The limits are intended to be used only with a TGMS. These limits are applicable on the outside rail in curves, as well as to any of the two rails of a tangent section in Class 9 track. The rationale discussed in section § 213.65, the companion provision to this section for lower-speed classes of track, also applies to this section. Please also note that in accordance with § 213.313, the limits specified for curved track apply only to track having a curvature greater than 0.25 degree.

#### Defect Codes

0332B	Combined track alinement and surface deviation exceeds allowable
-------	--

**§ 213.333 Automated vehicle-based inspection systems.**

**General Guidance:** This section contains requirements for automated, vehicle-based measurement systems - i.e., track geometry measurement systems, gage restraint measurement systems, and the systems necessary to monitor vehicle/track interaction (acceleration and wheel/rail forces). The section heading is revised as “Automated vehicle inspection systems” to reflect more clearly that the inspection systems are vehicle-based and are for inspecting track conditions and monitoring vehicle/track interactions.

*333(a) A qualifying Track Geometry Measurement System (TGMS) shall be operated at the following frequency:*

- (1) For operations at a qualified cant deficiency,  $E_u$ , of more than 5 inches on track Classes 1 through 5, at least twice per calendar year with not less than 120 days between inspections.*
- (2) For track Class 6, at least once per calendar year with not less than 170 days between inspections. For operations at a qualified cant deficiency,  $E_u$ , of more than 5 inches on track Class 6, at least twice per calendar year with not less than 120 days between inspections.*
- (3) For track Class 7, at least twice within any 120-day period with not less than 25 days between inspections.*
- (4) For track Classes 8 and 9, at least twice within any 60-day period with not less than 12 days between inspections.*

**Guidance:** Paragraph (a)(1) specifies new TGMS inspection requirements for low-speed, high cant deficiency (>5”) operations, which apply as required by, but are not provided in, § 213.57(i). These requirements are considered necessary for safe operations at high cant deficiency on lower-speed track classes.

Paragraph (a)(2) specifies TGMS inspection requirements for Class 6 track, with two different inspection frequencies depending on the amount of cant deficiency. The twice-yearly TGMS inspection requirements are for operations at a qualified cant deficiency of more than 5 inches. The inspection requirements can be fulfilled by either the track owner or the railroad.

Paragraph (a)(3) concerns TGMS inspections for Class 7 track. The number of days between inspections has been reduced from 30 days to 25 days.

Paragraph (a)(4) concerns TGMS inspections for Class 8 and 9 track. The number of days between two inspections has been reduced from 15 to 12 days.

*333(b) A qualifying TGMS shall meet or exceed minimum design requirements which specify that –*

- (1) Track geometry measurements shall be taken no more than 3 feet away from the contact point of wheels carrying a vertical load of no less than 10 kips per wheel, unless otherwise approved by FRA;*
- (2) Track geometry measurements shall be taken and recorded on a distance-based sampling interval preferably at 1 foot not exceeding 2 feet; and*
- (3) Calibration procedures and parameters are assigned to the system which assure that*

*measured and recorded values accurately represent track conditions. Track geometry measurements recorded by the system shall not differ on repeated runs at the same site at the same speed more than 1/8 inch.*

**Guidance:** Paragraph (b)(1) specifies the requirement that track geometry measurements be taken no more than 3 feet away from the contact point of wheels carrying a vertical load of no less than 10 kips per wheel. The phrase “unless otherwise approved by FRA” provides flexibility to conduct track geometry measurements using GRMS, hi-rail geometry equipment, and other test platforms that do not meet the measurement point or axle load requirement.

Paragraph (b)(2) specifies the track geometry measurement interval. Although most existing track geometry measurement systems record measurements at 1 foot or shorter intervals, there are systems that record the measurements at up to 2 foot intervals.

Adequate sampling intervals provide sufficient data to identify track geometry perturbations. The rule states that the 1-foot sampling interval is the preferable distance. However, an allowance is provided for sampling at up to a 2-foot interval depending on the circumstances involved so that track owners/railroads may continue to use existing equipment. In this regard, the rule allows for the use of GRMS, which takes measurement at 16-inch intervals. In addition, the use of equipment that takes measurement samples on a time-based interval at a rate that corresponds to the distance-based interval specified in this section is permitted.

*333(c) A qualifying TGMS shall be capable of measuring and processing the necessary track geometry parameters to determine compliance with—*

- (1) For operations at a qualified cant deficiency, Eu, of more than 5 inches on track Classes 1 through 5: § 213.53, Track gage; § 213.55(b), Track alinement; § 213.57, Curves; elevation and speed limitations; § 213.63, Track surface; and §213.65, Combined track alinement and surface deviations.*
- (2) For track Classes 6 through 9: § 213.323, Track gage; § 213.327, Track alinement; § 213.329, Curves; elevation and speed limitations; § 213.331, Track surface; and for operations at a cant deficiency of more than 5 inches § 213.332, Combined track alinement and surface deviations.*

**Guidance:** Paragraph (c) specifies the application of the added TGMS inspection requirements for high cant deficiency operations on lower-speed track classes. These requirements apply to vehicle types intended to operate at any curving speed producing more than 5 inches of cant deficiency, as provided in § 213.57(i). Requirements for track Classes 6 through 9 have been amended to reference § 213.332, the new section for combined track alinement and surface deviations.

*333(d) A qualifying TGMS shall be capable of producing, within 24 hours of the inspection, output reports that –*

- (1) Provide a continuous plot, on a constant-distance axis, of all measured track geometry parameters required in paragraph (c) of this section;*
- (2) Provide an exception report containing a systematic listing of all track geometry conditions which constitute an exception to the class of track over the segment surveyed.*



**Guidance:** This paragraph specifies the requirement for TGMS output. Although not implicitly mentioned, either or both reports specified in (d)(1) and (d)(2) can be in electronic format.

*333(e) The output reports required under paragraph (c) of this section shall contain sufficient location identification information which enable field forces to easily locate indicated exceptions.*

**Guidance:** This paragraph specifies that the report mentioned in (d)(1) and (d)(2) should have precise position locator, normally milepost and GPS coordinates.

*333(f) Following a track inspection performed by a qualifying TGMS, the track owner shall, within two days after the inspection, field verify and institute remedial action for all exceptions to the class of track.*

**Guidance:** Track owners are required to act on the exceptions identified by the TGMS within 48 hours following the TGMS inspection.

*333(g) The track owner or railroad shall maintain for a period of one year following an inspection performed by a qualifying TGMS, a copy of the plot and the exception report for the track segment involved, and additional records which:*

- (1) Specify the date the inspection was made and the track segment involved; and*
- (2) Specify the location, remedial action taken, and the date thereof, for all listed exceptions to the class.*

**Guidance:** This paragraph specifies the requirement for TGMS data retention to support appropriate usage of electronic information to comply with FRA's requirements. "Exception report" can be disseminated in electronic form, if the track owner/railroad chooses to do so.

*333(h) For track Classes 8 and 9, a qualifying Gage Restraint Measurement System (GRMS) shall be operated at least once per calendar year with at least 170 days between inspections. The lateral capacity of the track structure shall not permit a Gage Widening Projection (GWP) greater than 0.5 inch.*

**Guidance:** This paragraph mandates annual GRMS inspections for track Classes 8 and 9. The number of days (170 days) between inspections means to provide additional operational flexibility in scheduling inspections.

Gage Widening Projection (GWP) is limited to 0.5 inch. The method to determine the GWP is given in paragraph (i) below.

*333(i) A GRMS shall meet or exceed minimum design requirements specifying that—*

- (1) Gage restraint shall be measured between the heads of the rail:*
  - (i) At an interval not exceeding 16 inches;*
  - (ii) Under an applied vertical load of no less than 10 kips per rail; and*

(iii) Under an applied lateral load that provides a lateral/vertical load ratio of between 0.5 and 1.25<sup>10</sup>, and a load severity greater than 3 kips but less than 8 kips per rail. Load severity is defined by the formula:

$$S = L - cV$$

Where—

*S* = Load severity, defined as the lateral load applied to the fastener system (kips).

*L* = Actual lateral load applied (kips).

*c* = Coefficient of friction between rail/tie, which is assigned a nominal value of 0.4.

*V* = Actual vertical load applied (kips), or static vertical wheel load if vertical load is not measured.

(2) The measured gage and load values shall be converted to a GWP as follows:

$$GWP = (LTG - UTG) \times \frac{8.26}{L - 0.258 \times V}$$

Where—

*UTG* = Unloaded track gage measured by the GRMS vehicle at a point no less than 10 feet from any lateral or vertical load application.

*LTG* = Loaded track gage measured by the GRMS vehicle at a point no more than 12 inches from the lateral load application.

*L* = Actual lateral load applied (kips).

*V* = Actual vertical load applied (kips), or static vertical wheel load if vertical load is not measured.

*GWP* = Gage Widening Projection, which means the measured gage widening, which is the difference between loaded and unloaded gage, at the applied loads, projected to reference loads of 16 kips of lateral force and 33 kips of vertical force.

**Guidance:** Paragraph (i)(1) concerns specifications for a GRMS. The unit for loads is *kips*. Vertical load can be taken as static wheel load where vertical load is not measured.

Paragraph (i)(2) describes the GWP equation. The equation incorporates a correction for the weight of the testing vehicle. This correction is also intended to result in more uniform strength measurements across the variety of testing vehicles that are in operation.

The requirements for GRMS testing on Class 9 track, which is expected to have a superior track structure to the extent it supports high-speed operations on a dedicated right-of-way may potential be met by alternative means as per provisions of § 213.307. FRA's regulatory approval of high-speed operations on a dedicated right-of-way may allow for the use of inspection and maintenance criteria and procedures in the alternative to those contained in this subpart, including the GRMS inspection requirements in this paragraph, based upon a showing that at least an equivalent level of safety is provided.

333(j) As further specified for the combination of track class, cant deficiencies, and vehicles subject to paragraphs (j)(1) through (3) of this section, a vehicle having dynamic response characteristics that are representative of other vehicles assigned to the service shall be operated over the route at the revenue speed profile. The vehicle shall either be instrumented or equipped with a portable device that monitors onboard instrumentation on trains. Track personnel shall be notified when onboard accelerometers indicate a possible track-related

<sup>10</sup> GRMS equipment using load combinations developing L/V ratios that exceed 0.8 shall be operated with caution to protect against the risk of wheel climb by the test wheelset.

*problem. Testing shall be conducted at the frequencies specified in paragraphs (j)(1) through (3) of this section, unless otherwise determined by FRA after reviewing the test data required by this subpart.*

- (1) For operations at a qualified cant deficiency,  $E_u$ , of more than 5 inches on track Classes 1 through 6, carbody acceleration shall be monitored at least once each calendar quarter with not less than 25 days between inspections on at least one passenger car of each type that is assigned to the service; and*
- (2) For operations at track Class 7 speeds, carbody and truck accelerations shall be monitored at least twice within any 60-day period with not less than 12 days between inspections on at least one passenger car of each type that is assigned to the service; and*
- (3) For operations at track Class 8 or 9 speeds, carbody acceleration shall be monitored at least four times within any 7-day period with not more than 3 days between inspections on at least one non-passenger and one passenger carrying vehicle of each type that is assigned to the service, as appropriate. Truck acceleration shall be monitored at least twice within any 60-day period with not less than 12 days between inspections on at least one passenger carrying vehicle of each type that is assigned to the service, as appropriate.*

**Guidance:** This paragraph specifies requirements for monitoring carbody and truck accelerations with emphasis on monitoring frequency. The rule also provides an option to use a portable device when performing the acceleration monitoring.

Paragraph (j)(1) includes monitoring requirements for operations above 5 inches of cant deficiency on track Classes 1 through 6. These requirements apply to vehicle types qualified to operate at any curving speed producing more than 5 inches of cant deficiency, as provided in § 213.57(i) and § 213.345(a), as appropriate.

Paragraph (j)(2) applies to operations at track Class 7 speeds, and requires that carbody and truck accelerations be monitored at least twice within any 60-day period, with a minimum of 12 days between inspections on at least one passenger car of each type that is assigned to the service.

Paragraph (j)(3) contains the requirements for monitoring carbody and truck accelerations of equipment operating at Track Class 8 and 9 speeds. The monitoring frequency is four times within any 7-day period for carbody accelerations, and twice within 60 days for truck accelerations. These frequencies are supported by data collected in the past years.

The requirements apply as specified for the combination of track class, cant deficiencies, and vehicles subject to paragraphs (j)(1) through (3). Consequently, the acceleration monitoring requirements in paragraphs (j)(1) and (2) for speeds up to 125 m.p.h. do not apply to equipment operated in a freight train. Requirements in paragraph (j)(3) apply to equipment operating in a freight train only at speeds above 125 m.p.h., and only as appropriate. If no passenger-carrying vehicles are assigned to the service, there will be no passenger-carrying vehicles to monitor. In the case of Amtrak's Acela service at track Class 8 speeds, the carbody acceleration monitoring requirements of paragraph (j)(3) require only one power car (locomotive), i.e., non-passenger carrying vehicle, and one trailer car (passenger coach) to be monitored. In the current Acela service, the café cars, first class cars, and business class cars are all passenger-carrying vehicles of the same dynamic response type and hence considered as one type of passenger-carrying vehicle.

- 333(k)(1) The instrumented vehicle or the portable device, as required in paragraph (j) of this section, shall monitor lateral and vertical accelerations of the carbody. The accelerometers shall be attached to the carbody on or under the floor of the vehicle, as near the center of a truck as practicable.*
- (2) In addition, a device for measuring lateral accelerations shall be mounted on a truck frame at a longitudinal location as close as practicable to an axle's centerline (either outside axle for trucks containing more than 2 axles), or, if approved by FRA, at an alternate location. After monitoring this data for 2 years, or 1 million miles, whichever occurs first, the track owner or railroad may petition FRA for exemption from this requirement.*
- (3) If any of the carbody lateral, carbody vertical, or truck frame lateral acceleration safety limits in this section's table of vehicle/track interaction safety limits is exceeded, corrective action shall be taken as necessary. Track personnel shall be notified when the accelerometers indicate a possible track-related problem.*

**Guidance:** This paragraph specifies the requirement for monitoring carbody and truck accelerations, with emphasis on monitoring methods and remedial actions.

Paragraph (k)(1) clarifies the requirements for locating the carbody accelerometers.

Paragraph (k)(2) clarifies the requirements for locating the truck accelerometers. It also gives the track owner or railroad an option to petition FRA for exemption from this monitoring requirement after the specified monitoring criteria in this paragraph have been met.

Paragraph (k)(3) clarifies the requirements for remedial actions when carbody or truck frame lateral acceleration safety limits in this section's table of vehicle/track interaction safety limits are exceeded. Track personnel must be notified when the accelerometers indicate a possible track-related problem.

*333(l) For track Classes 8 and 9, the track owner or railroad shall submit a report to FRA, once each calendar year, which provides an analysis of the monitoring data collected in accordance with paragraphs (j) and (k) of this section. Based on a review of the report, FRA may require that an instrumented vehicle having dynamic response characteristics that are representative of other vehicles assigned to the service be operated over the track at the revenue speed profile. The instrumented vehicle shall be equipped to measure wheel/rail forces. If any of the wheel/rail force limits in this section's table of vehicle/track interaction safety limits is exceeded, appropriate speed restrictions shall be applied until corrective action is taken.*

**Guidance:** This paragraph contains requirements for conducting instrumented wheelset (IWS) testing on Class 8 and 9 track. IWS testing is not a general requirement applicable for all Class 8 and 9 track. Based on review of past Acela Express trainset IWS data and in consideration of the economics associated with the testing, there has been significant cost and little apparent safety benefit associated with IWS testing on an annual basis. The specific need to perform IWS testing will be determined by FRA on a case-by-case basis, after reviewing a report submitted annually by the track owner or railroad, detailing the accelerometer monitoring data collected in accordance with paragraphs (j) and (k) of this section.

*333(m) The track owner or railroad shall maintain a copy of the most recent exception records*

for the inspections required under paragraphs (j), (k), and (l) of this section, as appropriate.

**Guidance:** This paragraph requires that the track owner or railroad maintain a copy of the most recent exception records for the inspections required under paragraphs (j) and (k) of this section, and, as appropriate, paragraph (l) should IWS testing be required.

The exception data shall be maintained as a record, but not necessarily a printed record. Each railroad or track owner is in the best position to determine the most efficient and effective method for keeping this information. The information may be maintained electronically. In this regard, § 213.369(f) requires that each vehicle/track interaction safety record required under § 213.333(g) and (m) be made available for inspection and copying by FRA, and § 213.369(e) sets conditions for maintaining records in an electronic system (or electronic record keeping).

**Vehicle/Track Interaction Safety Limits**

<b>Wheel-Rail Forces <sup>1</sup></b>			
<b>Parameter</b>	<b>Safety Limit</b>	<b>Filter/Window</b>	<b>Requirements</b>
Single Wheel Vertical Load Ratio	$\geq 0.15$	5 ft	No wheel of the vehicle shall be permitted to unload to less than 15 percent of the static vertical wheel load for 5 or more continuous feet. The static vertical wheel load is defined as the load that the wheel would carry when stationary on level track.
Single Wheel L/V Ratio	$\leq \frac{\tan(\delta) - 0.5}{1 + 0.5 \tan(\delta)}$	5 ft	The ratio of the lateral force that any wheel exerts on an individual rail to the vertical force exerted by the same wheel on the rail shall not be greater than the safety limit calculated for the wheel's flange angle ( $\delta$ ) for 5 or more continuous feet.
Net Axle Lateral L/V Ratio	$\leq 0.4 + \frac{5.0}{V_a}$	5 ft	The net axle lateral force, in kips, exerted by any axle on the track shall not exceed a total of 5 kips plus 40 percent of the static vertical load that the axle exerts on the track for 5 or more continuous feet. <i>V<sub>a</sub> = static vertical axle load (kips)</i>
Truck Side L/V Ratio	$\leq 0.6$	5 ft	The ratio of the lateral forces that the wheels on one side of any truck exert on an individual rail to the vertical forces exerted by the same wheels on that rail shall not be greater than 0.6 for 5 or more continuous feet.
<b>Carbody Accelerations <sup>2</sup></b>			

<b>Parameter</b>	<b>Passenger Cars</b>	<b>Other Vehicles</b>	<b>Requirements</b>
<i>Carbody Lateral (Transient)</i>	$\leq 0.65g$ peak-to-peak 1 sec window <sup>3</sup> excludes peaks < 50 msec	$\leq 0.75g$ peak- to-peak 1 sec window <sup>3</sup> excludes peaks < 50 msec	<i>The peak-to-peak accelerations, measured as the algebraic difference between the two extreme values of measured acceleration in any 1-second time period, excluding any peak lasting less than 50 milliseconds, shall not exceed 0.65g and 0.75g for passenger cars and other vehicles, respectively.</i>
<i>Carbody Lateral (Sustained Oscillatory)</i>	$\leq 0.10g$ $RMS_t^4$ 4 sec window <sup>3</sup> 4 sec sustained	$\leq 0.12g$ $RMS_t^4$ 4 sec window <sup>3</sup> 4 sec sustained	<i>Sustained oscillatory lateral acceleration of the carbody shall not exceed the prescribed (root mean squared) safety limits of 0.10g and 0.12g for passenger cars and other vehicles, respectively. Root mean squared values shall be determined over a sliding 4-second window with linear trend removed and shall be sustained for more than 4 seconds.</i>
<i>Carbody Vertical (Transient)</i>	$\leq 1.0g$ peak- to-peak 1 sec window <sup>3</sup> excludes peaks < 50 msec	$\leq 1.25g$ peak- to-peak 1 sec window <sup>3</sup> excludes peaks < 50 msec	<i>The peak-to-peak accelerations, measured as the algebraic difference between the two extreme values of measured acceleration in any one second time period, excluding any peak lasting less than 50 milliseconds, shall not exceed 1.0g, or 1.25g, as specified.</i>
<i>Carbody Vertical (Sustained Oscillatory)</i>	$\leq 0.25g$ $RMS_t^4$ 4 sec window <sup>3</sup> 4 sec sustained	$\leq 0.25g$ $RMS_t^4$ 4 sec window <sup>3</sup> 4 sec sustained	<i>Sustained oscillatory vertical acceleration of the carbody shall not exceed the prescribed (root mean squared) safety limit of 0.25g. Root mean squared values shall be determined over a sliding 4-second window with linear trend removed and shall be sustained for more than 4 seconds.</i>
<b>Truck Lateral Acceleration<sup>5</sup></b>			
<b>Parameter</b>	<b>Safety Limit</b>	<b>Filter/ Window</b>	<b>Requirements</b>
<i>Truck Lateral</i>	$\leq 0.30g$ $RMS_t^4$	2 sec window <sup>3</sup>	<i>Truck hunting shall not develop below the maximum authorized speed.</i>

		2 sec sustained	Truck hunting is defined as a sustained cyclic oscillation of the truck evidenced by lateral accelerations exceeding 0.3g root mean squared for more than 2 seconds. Root mean squared values shall be determined over a sliding 2-second window with linear trend removed.
--	--	-----------------	---

<sup>1</sup> The lateral and vertical wheel forces shall be measured and processed through a low pass filter (LPF) with a minimum cut-off frequency of 25 Hz. The sample rate for wheel force data shall be at least 250 samples per second.

<sup>2</sup> Carbody accelerations in the vertical and lateral directions shall be measured by accelerometers oriented and located in accordance with § 213.333(k).

<sup>3</sup> Acceleration measurements shall be processed through an LPF with a minimum cut-off frequency of 10 Hz. The sample rate for acceleration data shall be at least 100 samples per second.

<sup>4</sup>  $RMS_t = RMS$  with linear trend removed.

<sup>5</sup> Truck lateral acceleration shall be measured on the truck frame by accelerometers oriented and located in accordance with § 213.333(k).

**Guidance on the Vehicle/Track Interaction Safety Limits:** The limits in the above table have been updated from the 1998 rule:

- The single wheel vertical load ratio limit is to ensure an adequate safety margin for wheel unloading. The ratio actually means percentage, as explained in the “Requirements” column on the right. That is, 0.15 means 15% of the static vertical wheel load. For example, if the static wheel load is 20 kips, the wheel load during the testing must measure 3 (20 x 15%) kips or greater for the specified window.
- The net axle lateral L/V ratio limit takes into account the effect of axle load and more appropriately reflect the cumulative, detrimental effect of track panel shift from heavier vehicles. This net axle lateral load limit is intended to control excessive lateral track shift and is sensitive to a number of track parameters. The well-established European Prud’homme limit is a function of the axle load and this sensitivity is desired to differentiate between coach car and heavier locomotive loads. Computer simulations and testing indicated the dependence on axle load and the importance of initial, small lateral deflections.
- To accommodate variations in vehicle design requirements and passenger ride safety, the carbody accelerations have separate limits for “Passenger Cars” and “Other Vehicles” (such as conventional locomotives).
- The lateral carbody transient acceleration limits also differentiate passenger cars (0.65g) and other vehicles (0.75g).
- The vertical carbody transient acceleration, as with lateral carbody transient acceleration limits, differentiate passenger cars (1.0g) and other vehicles (1.25g).

These limits were developed after considerable research into the performance of existing vehicles during qualification testing and revenue operations. It was found that the carbody transient acceleration limits need not be as stringent as the limits in the 1998 rule to protect against events leading to vehicle or passenger safety issues. In addition, transient acceleration peaks lasting less than 50 milliseconds have been excluded because the

energy content associated with high-frequency carbody acceleration events is small.

Limits for sustained carbody lateral oscillatory accelerations are set at 0.10g RMS<sub>t</sub> (root mean squared with linear trend removed) for passenger cars and 0.12g RMS<sub>t</sub> for other vehicles. The sustained vertical carbody oscillatory acceleration limits are 0.25g RMS<sub>t</sub> for both passenger cars and other vehicles.

These new limits require that the RMS<sub>t</sub> value be used in order to attenuate the effects of the linear variation in oscillatory accelerations resulting from a vehicle negotiating track segments with changes in curvature or grade by design, such as spirals. Root mean squared values shall be determined over a sliding 4-second window with linear trend removed and be sustained for more than 4 seconds.

Minimum requirements for sampling and filtering of the acceleration data have been specified. Acceleration measurements shall be processed through a low-pass filter with a minimum cut-off frequency of 10 Hz, and the sample rate for oscillatory acceleration data need be at least 100 samples per second.

The truck lateral acceleration limit used for the detection of truck hunting is 0.3g. The value would have to be exceeded the limit for more than 2 seconds to be considered as an exceedance. Analyses conducted by FRA have shown that this limit will help better identify the occurrences of excessive truck hunting, while excluding high-frequency, low-amplitude oscillations that do not require immediate attention. In addition, this limit requires that the RMS<sub>t</sub> value be used rather than the RMS<sub>m</sub> (root mean squared with mean removed) value, to improve the process for analyzing data while the vehicle is negotiating spiral track segments.

It is of utmost importance that the inspector monitors the railroad's compliance with this requirement. The term "representative" does not mean that every type of car which operates at Classes 8 and 9 speeds is required to be equipped with instrumented wheelsets to measure wheel/rail forces, but the instrumented car must be representative of the equipment operating at those speeds. If the inspector has any doubt as to the effectiveness of the railroad's measurement of wheel/rail forces and its program to initiate remedial action, the inspector should contact the regional track specialist who shall seek the assistance of Headquarter's specialists to evaluate the railroad's program. The railroad must maintain a copy of the most recent exception report.

The vehicle/track interaction safety limits are the cornerstone of the high-speed standards. Vehicle/track interaction has critical consequences in railroad safety, and so establishing safe parameters and developing a measurement system to adhere to those parameters is highly important for any track safety program. There are several hazardous and unacceptable vehicle/track interaction events that are well-known in railroad engineering, and for the most part, may occur on existing high-speed operations, including wheel climb, rail roll-over, vehicle overturning, gage widening, and track panel shift.

#### Defect Codes

0333A1	Failure to operate qualified TGMS as required.
0333A2	Failure to inspect using TGMS at required frequency.
0333D2	Failure to make TGMS records available for inspection.
0333F1	Failure to field verify an TGMS exception within two days.
0333F2	Failure to initiate remedial action for TGMS exception within two days.



0333G1	Failure of TGMS report to provide required information, date or track segment.
0333G2	Failure of TGMS report to provide required information, location, remedial action and date thereof.
0333H1	Failure to operate GRMS at required frequency.
0333H2	Lateral track capacity of track structure permits a gage widening ratio greater than allowed.
0333J1	Failure to equip at least one vehicle per day with required accelerometers.
0333J2	Failure to have written procedures for notification of track personnel when daily accelerometer measurements indicate a possible track-related condition.
0333J3	Failure to follow written procedures for notification of track personnel when daily accelerometer measurements indicate a possible track-related condition.
0333K1	Failure to operate an instrumented car or portable device to measure carbody and truck frame accelerations at required frequency.
0333K2	Failure to reduce train speeds when carbody and truck frame accelerations exceed allowable.
0333L1	Failure to operate an inspection vehicle with instrumented wheelsets to measure wheel/rail forces at required frequency.
0333L2	Failure to reduce train speed when wheel/rail forces exceed allowable.
0333M1	Failure to keep record of wheel/rail force measurements as required.
0333M2	Failure to keep records of acceleration measurements as required.

### **§ 213.334 Ballast; general**

*Unless it is otherwise structurally supported, all track shall be supported by material which will --*

*334(a) Transmit and distribute the load of the track and railroad rolling equipment to the subgrade;*

*334(b) Restrain the track laterally, longitudinally, and vertically under dynamic loads imposed by railroad rolling equipment and thermal stress exerted by the rails;*

*334(c) Provide adequate drainage for the track; and*

*334(d) Maintain proper track crosslevel, surface, and alinement.*

**Guidance:** Ballast may consist of crushed slag, crushed stone, screened gravel, pit-run gravel, chat, cinders, scoria, pumice, sand, mine waste, or other native material, and is an integral part of the track structure. Ballast, regardless of the material, must satisfy all four of the requirements stated in the Track Safety Standards (TSS) for this section.

The sole appearance of fouled ballast (ballast contaminated with broken down ballast particles, mud, coal dust, or any foreign particles) does not warrant a defect or violation to be written, if the ballast section is properly transmitting the load, restraining the track, providing adequate drainage, and maintaining proper geometry. However, fouled ballast that is unable to provide adequate drainage, as required by paragraph (c) of this section, is of particular concern because it compromises the ability of ballast to meet its other three

functions (i.e., to distribute load, restrain track, and maintain proper geometry). When fouled ballast with inadequate drainage is present, wheel loads are likely to be concentrated, rather than distributed, causing deterioration of components and instability in the area of the defective ballast. This deterioration of components and instability increases the risk of track shift (such as a track buckle) and also increases the rate of degradation of geometry, and may result in a derailment. Other factors that affect the rate of degradation of components and geometry include the tonnage, traffic density, and operating speeds, as higher tonnage, traffic density, and operating speeds increase the amount and/or frequency of the forces exerted on the components.

Inspectors should consider the overall condition of a track when citing a ballast defect or violation (including fouled ballast or other failure modes that render the ballast unable to perform any one of its four functions). In doing so, inspectors should look for indicators that the ballast is not performing its four functions, such as the existence of a crosstie and/or geometry condition. For example, a ballast violation may be warranted if the track has poor drainage and there is a geometry condition or a series of fouled ballast locations with geometry conditions.

The inspector should also consider the safety and risk issues when considering whether to recommend enforcement action. As such, the inspector should not typically issue a defect or violation in FRA Class 1 track or other than main track with speeds of 10 mph or less unless there is a significant risk of derailment with the potential for catastrophic consequence (e.g., a fouled ballast location with a significant geometry condition on a higher-tonnage passenger train or hazardous materials route). In such situations, any enforcement action should be taken in consultation with the inspector's regional specialist.

The term "geometry condition" used here and elsewhere in this manual means a track surface, gage, or alignment irregularity that does not exceed the allowable threshold for the designated track class in the TSS. It exists due to the reduced or nonexistent capability of one or more components of the track structure to hold the track to its preferred geometric position.

Inspectors are encouraged to exercise their technical knowledge and professional experience in citing fouled ballast, and should take into account the severity of a geometry condition along with the following factors when considering enforcement action:

- Track class and operating speed
- Traffic density and wheel loads
- Adequacy of shoulder ballast and crib ballast
- Track type: passenger, hazardous materials, or STRACNET route
- Potential that the track may deteriorate very rapidly following heavy rains
- Center-bound crossties, if observable
- Rail and fastener conditions
- Subgrade condition

- Surrounding track structure (embankment or cut, obvious/observable variation of track stiffness of the left from right side of the track, and from the adjacent areas along the track)
- Proximity of the defective ballast locations to switches, joints, or bridges
- Existence of standing water or indications that water had been standing (as water sometimes gets trapped beneath the ties and may not be visible on the surface). Note: If the standing water appears to be due to obstructed drainage facilities, enforcement action may be more appropriate under 49 CFR § 213.33.

**Defect Codes**

0334A	Fouled or insufficient ballast failing to transmit and distribute loading
0334B	Fouled or insufficient ballast failing to restrain the track laterally, longitudinally or vertically.
0334C	Fouled ballast failing to provide adequate drainage for the track.
0334D	Fouled or insufficient ballast failing to maintain proper geometry.

**§ 213.335 Crossties**

335(a) *Crossties shall be made of a material to which rail can be securely fastened.*

335(b) *Each 39 foot segment of track shall have --*

(1) *A sufficient number of crossties which in combination provide effective support that will –*

- (i) *Hold gage within the limits prescribed in § 213.323(b);*
- (ii) *Maintain surface within the limits prescribed in § 213.331; and*
- (iii) *Maintain alinement within the limits prescribed in § 213.327.*

(2) *The minimum number and type of crossties specified in paragraph (c) of this section effectively distributed to support the entire segment; and*

(3) *Crossties of the type specified in paragraph (c) of this section that are(is) located at a joint location as specified in paragraph (e) of this section.*

**Guidance:** When determining compliance with this section, the inspector must ascertain that crossties meet the “definitional” requirements of soundness, and make geometry measurements to verify that each 39-foot segment of track has:

- A sufficient number of effective ties to maintain geometry;
- The required number of sound ties for the track class as described in paragraph (c) and (d);and
- The proper placement of sound ties as described and positioned in paragraph (e) to support joints.

The failure of the crossties to meet any of the three above criteria constitutes a deviation from the TSS.

If track geometry measurements fail to meet the requirements of §§ 213.323, 213.327 and 213.331, and there is an insufficient number of sound crossties, both geometry and crossties could be cited as defects. If geometry measurements exceed the allowable tolerance, but a determination cannot be made that crossties are at fault, it is appropriate to cite only the defective geometry condition.

Each tie must be evaluated individually by the criteria described for timber crossties in paragraph (c) and for concrete crossties in paragraph (d) below.

When determining compliance with the minimum number of non-defective crossties per 39-foot segment, inspectors are reminded that the 39-foot segment may be taken anywhere along the track and need not coincide with joint locations. This portion of the rule applies independently of any other provision of the TSS; it does not require associated evidence of actual or incipient geometry defects or other defective conditions.

A non-defective joint tie must be found within the prescribed distance of the centerline of the joint measured at the rail and not at the centerline of track. Where a very short piece of rail exists within the joint bar, measure from the bar centerline. Where non-symmetrical bars exist (five-hole bars), measure from the design point where rail ends normally abut.

Effective distribution has not been defined, but must not be interpreted by the inspector as synonymous with equally-spaced. The language is intended to address situations where all of the non-defective ties exist in a group at a short area of the 39-foot segment of track in question. Evidence that crossties are not effectively distributed primarily includes indications of actual or incipient deviations from the geometry standards. For example, 5 dysfunctional ties in a row will not provide effective support to hold gage, maintain surface and alinement. The word “incipient” means “beginning to appear.”

*335(c) For non-concrete tie construction, each 39 foot segment of Class 6 track shall have fourteen crossties; Classes 7, 8 and 9 shall have 18 crossties which are not –*

- (1) Broken through;*
- (2) Split or otherwise impaired to the extent the crossties will allow the ballast to work through, or will not hold spikes or rail fasteners;*
- (3) So deteriorated that the tie plate or base of rail can move laterally 3/8 inch relative to the crossties;*
- (4) Cut by the tie plate through more than 40 percent of a crosstie's thickness;*
- (5) Configured with less than 2 rail holding spikes or fasteners per tie plate; or*
- (6) So unable, due to insufficient fastener toeload, to maintain longitudinal restraint and maintain rail hold down and gage.*

*335(d) For concrete tie construction, each 39 foot segment of Class 6 track shall have fourteen crossties, Classes 7, 8 and 9 shall have 16 crossties which are not--*

- (1) So deteriorated that the prestress strands are ineffective or withdrawn into the tie at one end and the tie exhibits structural cracks in the rail seat or in the gage of track;*
- (2) Configured with less than 2 fasteners on the same rail;*

- (3) *So deteriorated in the vicinity of the rail fastener such that the fastener assembly may pull out or move laterally more than 3/8-inch relative to the crosstie;*
- (4) *So deteriorated that the fastener base plate or base of rail can move laterally more than \_ inch relative to the crossties;*
- (5) *So deteriorated that rail seat abrasion is sufficiently deep so as to cause loss of rail fastener toeload;*
- (6) *Completely broken through; or*
- (7) *So unable, due to insufficient fastener toeload, to maintain longitudinal restraint and maintain rail hold down and gage.*

**Guidance:** When citing Defect Code 0335C or D, the inspector must show evidence of one or more of the geometry conditions cited in § 213.335(b)(1). Several factors should be documented if the defect is being cited as a violation. These factors include, but are not limited to:

- Geometry conditions
- Class of track
- Curvature
- Traffic density (annual tonnage)
- Rail weight and condition
- Condition of other components of the track

FRA inspectors may use a Portable Track Loading Fixture (PTLF) described in § 213.110 for the purposes of measuring loaded gage to determine effective distribution of crossties.

The inspector must use judgment and discretion in the application of the crosstie standards. They should be used to describe conditions that constitute a risk to the safe operation of trains, and should not be applied in doubtful cases.

No criterion now exists for the maximum distance between non-defective ties, and this measurement should not be used to describe a tie defect. If such a description is appropriate, it should be in terms of the number of adjacent non-defective ties in a group.

*335(e) Class 6 track shall have one non-defective crosstie whose centerline is within 18 inches of the rail joint location or two crossties whose center lines are within 24 inches either side of the rail joint location. Class 7, 8, and 9 track shall have two non-defective ties within 24 inches each side of the rail joint.*

**Guidance:** This paragraph dictates that there must be one effective tie on each side of a joint, within the distance specifies for the class of track.

*335(f) For track constructed without crossties, such as slab track and track connected directly to bridge structural components, the track structure shall meet the requirements of paragraphs (b)(1)(i), (ii), and (iii) of this section.*

**Guidance:** This paragraph addresses track constructed without conventional crossties, such as concrete-slab track in which the running rails are secured through fixation to

another structural member. Railroads are required to maintain gage, surface, and alignment to the standards specified in paragraphs (b)(1)(i), (ii), and (iii).

For non-concrete-tied construction, the requirements for ties parallel those of the lower standards, except that permissive lateral movement of tie plates is set at 3/8-inch instead of 1/2-inch and a requirement for rail holding spikes is added.

*335(g) In Classes 7, 8 and 9 there shall be at least three non-defective ties each side of a defective tie.*

**Guidance:** This is an absolute requirement for Classes 7, 8, and 9. There must be at least three non-defective ties of each side of a defective tie. Inspectors must determine the effectiveness of the ties using the criteria listed in subsection (b) and (c) since the requirements in this paragraph are more restrictive than those in 335(b) and (c).

*335(h) Where timber crossties are in use there shall be tie plates under the running rails on at least nine of 10 consecutive ties.*

**Guidance:** During an inspection, if the inspector finds a missing tie plate under the rails, the inspector must determine that tie plates are under at least nine out of 10 consecutive ties.

*335(i) No metal object which causes a concentrated load by solely supporting a rail shall be allowed between the base of the rail and the bearing surface of the tie plate.*

**Guidance:** The reference to a metal object in paragraph (j) is intended to include only those items of track material which pose the greatest potential for broken base rails such as track spikes, rail anchors, and shoulders of tie plates. The phrase “causes a concentrated load by solely supporting a rail” further clarifies the intent of the regulation to apply only in those instances where there is clear physical evidence that the metal object is placing substantial load on the rail base, as indicated by lack of load on adjacent ties.

**Defect Codes**

0335A	Crossties not made of material to which rail can be securely fastened
0335B2	Fewer than minimum allowable number of non-defective ties per 39 feet.
0335C	Insufficient number of non-defective non-concrete ties to support a 39-foot segment of track
0335D	Insufficient number of non-defective concrete ties to support a 39-foot segment of track
0335E	No effective support ties within the prescribed distance from a joint.
0335F	Track constructed without crossties does not effectively support track structure.
0335G	Fewer than three non-defective ties each side of a defective tie.
0335H	Less than nine out of 10 consecutive ties with tie plates.
0335I	Metal object causing concentrated load between base of rail and bearing surface of tie plate.

**§ 213.337 Defective rails**

337(a) When an owner of track to which this part applies learns, through inspection or otherwise, that a rail in that track contains any of the defects listed in the following table, a person designated under § 213.305 shall determine whether or not the track may continue in use. If the person determines that the track may continue in use, operation over the defective rail is not permitted until --

- (1) The rail is replaced; or
- (2) The remedial action prescribed in the table is initiated –

**REMEDIAL ACTION**

Defect	Length of defect (inch)		Percent of rail head cross-sectional area weakened by defect		If defective rail is not replaced, take the remedial action prescribed in note
	More than	But not more than	Less than	But not less than	
Transverse fissure			70..... 100....	5..... 70..... 100....	B. A2. A.
Compound fissure			70..... 100....	5 70 100	B. A2. A.
Detail fracture Engine burn fracture Defective weld			25..... 80..... 100....	5 25 80 100	C. D. A2 or [E and H] A or [E and H]
Horizontal or Vertical split head Split web Piped rail Head web separation	1 2 4..... ( <sup>1</sup> )	2..... 4..... ..... ( <sup>1</sup> )	..... ..... ..... ( <sup>1</sup> )	..... ..... ..... .....	H and F. I and G. B. A.
Bolt hole crack	½ 1 1½ ( <sup>1</sup> )	½ 1 ..... ( <sup>1</sup> )	..... ..... ..... ( <sup>1</sup> )	..... ..... ..... .....	H and F. I and G. B. A.
Broken base	1 6	6 .....	..... .....	..... .....	D A or [E and I]
Ordinary break	.....	.....	.....	.....	A or E.
Damaged rail	.....	.....	.....	.....	D.
Flattened rail	Depth ≥ ⅜ and Length ≥ 8	.....	.....	.....	H.

(<sup>1</sup>) Breakout in rail head.

*Notes:*

*A. Assign person designated under § 213.305 to visually supervise each operation over defective rail.*

*A2. Assign person designated under § 213.305 to make visual inspection. That person may authorize operation to continue without visual supervision at a maximum of 10 mph for up to 24 hours prior to another such visual inspection or replacement or repair of the rail.*

*B. Limit operating speed over defective rail to that as authorized by a person designated under § 213.305(a)(1)(i) or (ii). The operating speed cannot be over 30 mph.*

*C. Apply joint bars bolted only through the outermost holes to defect within 20 days after it is determined to continue the track in use. Limit operating speed over defective rail to 30 mph until joint bars are applied; thereafter, limit speed to 50 mph. When a search for internal rail defects is conducted under § 213.339 and defects are discovered which require remedial action C, the operating speed shall be limited to 50 mph, for a period not to exceed 4 days. If the defective rail has not been removed from the track or a permanent repair made within 4 days of the discovery, limit operating speed over the defective rail to 30 mph until joint bars are applied; thereafter, limit speed to 50 mph.*

*D. Apply joint bars bolted only through the outermost holes to defect within 10 days after it is determined to continue the track in use. Limit operating speed over the defective rail to 30 mph or less as authorized by a person designated under § 213.305(a)(1)(i) or (ii) until joint bars are applied; thereafter, limit speed to 50 mph.*

*E. Apply joint bars to defect and bolt in accordance with § 213.351(d) and (e).*

*F. Inspect rail 90 days after it is determined to continue the track in use.*

*G. Inspect rail 30 days after it is determined to continue the track in use.*

*H. Limit operating speed over defective rail to 50 mph.*

*I. Limit operating speed over defective rail to 30 mph.*

*337(b) As used in this section –*

*(1) Transverse Fissure means a progressive crosswise fracture starting from a crystalline center or nucleus inside the head from which it spreads outward as a smooth, bright, or dark, round or oval surface substantially at a right angle to the length of the rail. The distinguishing features of a transverse fissure from other types of fractures or defects are the crystalline center or nucleus and the nearly smooth surface of the development which surrounds it.*

*(2) Compound Fissure means a progressive fracture originating in a horizontal split head which turns up or down in the head of the rail as a smooth, bright, or dark surface progressing until substantially at a right angle to the length of the rail. Compound fissures require examination of both faces of the fracture to locate the horizontal split head from which they originate.*



- (3) *Horizontal Split Head means a horizontal progressive defect originating inside of the rail head, usually one-quarter inch or more below the running surface and progressing horizontally in all directions, and generally accompanied by a flat spot on the running surface. The defect appears as a crack lengthwise of the rail when it reaches the side of the rail head.*
- (4) *Vertical Split Head means a vertical split through or near the middle of the head, and extending into or through it. A crack or rust streak may show under the head close to the web or pieces may be split off the side of the head.*
- (5) *Split Web means a lengthwise crack along the side of the web and extending into or through it.*
- (6) *Piped Rail means a vertical split in a rail, usually in the web, due to failure of the shrinkage cavity in the ingot to unite in rolling.*
- (7) *Broken Base means any break in the base of the rail.*
- (8) *Detail Fracture means a progressive fracture originating at or near the surface of the rail head. These fractures should not be confused with transverse fissures, compound fissures, or other defects which have internal origins. Detail fractures may arise from shelly spots, head checks, or flaking.*
- (9) *Engine Burn Fracture means a progressive fracture originating in spots where driving wheels have slipped on top of the rail head. In developing downward they frequently resemble the compound or even transverse fissures with which they should not be confused or classified.*
- (10) *Ordinary Break means a partial or complete break in which there is no sign of a fissure, and in which none of the other defects described in this paragraph (b) are found.*
- (11) *Damaged Rail means any rail broken or injured by wrecks, broken, flat, or unbalanced wheels, slipping, or similar causes.*
- (12) *Flattened Rail means a short length of rail, not a joint, which has flattened out across the width of the rail head to a depth of  $\frac{1}{8}$  inch or more below the rest of the rail. Flattened rail occurrences have no repetitive regularity and thus do not include corrugations, and have no apparent localized cause such as a weld or engine burn. Their individual length is relatively short, as compared to a condition such as head flow on the low rail of curves.*
- (13) *Bolt Hole Crack means a crack across the web, originating from a bolt hole, and progressing on a path either inclined upward toward the rail head or inclined downward toward the base. Fully developed bolt hole cracks may continue horizontally along the head/web or base/web fillet, or they may progress into and through the head or base to separate a piece of the rail end from the rail. Multiple cracks occurring in one rail end are considered to be a single defect. However, bolt hole cracks occurring in adjacent rail ends within the same joint shall be reported as separate defects.*
- (14) *Defective Weld means a field or plant weld containing any discontinuities or pockets, exceeding 5 percent of the rail head area individually or 10 percent in the aggregate, oriented in or near the transverse plane, due to incomplete penetration of the weld metal*

*between the rail ends, lack of fusion between weld and rail end metal, entrainment of slag or sand, under-bead or other shrinkage cracking, or fatigue cracking. Weld defects may originate in the rail head, web, or base, and in some cases, cracks may progress from the defect into either or both adjoining rail ends.*

- (15) *Head and Web Separation means a progressive fracture, longitudinally separating the head from the web of the rail at the head fillet area.*

**Guidance:** The remedial actions required for defective rails specify definite time limits and speeds, and allow certain discretion to the track owner for the continued operation over a defect. All rail defects should be considered dangerous by the inspector and care should be taken to determine that proper remedial action has been undertaken by the railroad. When more than one defect is present in a rail, the defect requiring the most restrictive remedial action shall govern.

The remedial action table and specifications in the rule address the risks associated with rail failure. These risks are primarily dependent upon defect type and size and should not be dependent upon the manner or mechanism that reveals the existence of the defect. Failure of the track owner to comply with the operational (speed) restrictions, maintenance procedures and the prescribed inspection intervals specified in § 213.337 and § 213.339 (defective rails and inspection of rail, respectively), may constitute a violation of the TSS.

Note “A2” addresses mid-range transverse defect sizes. This remedial action allows for train operations to continue at a maximum of 10 mph up to 24 hours, following a visual inspection by a person designated under § 213.305. If the rail is not replaced, another 24-hour cycle begins.

Note “B” limits speed to 30 mph as authorized by a § 213.305 designated person. Notes “C,” “D,” and “H” limit the operating speed, following the application of joint bars, to 50 mph.

The remedial action table for defects failing in the transverse plane (transverse and compound fissures, detail and engine burn fractures, and defective welds) specifies a lower limit range base of five percent of the railhead cross sectional area. If a transverse defect is reported to be less than five percent, the track owner is not legally bound to correct and no remedial action would be required under the TSS. Defects reported less than five percent are not consistently found during rail breaking routines and therefore, defect determination within this range is not always reliable.

Transverse and compound fissure defects, weakened between five and 70 percent of cross-sectional head area, require remedial action (note B), as indicated by the prescribed notes. Defects in the range between 70 and less than 100 percent of cross-sectional head area, require remedial action (note A2), as prescribed. Defects that affect 100 percent of the cross-sectional head area, require remedial action (note A) as prescribed, the most restrictive. Inspectors should be aware that transverse and compound fissures are defects that fail in the transverse plane and are characteristic of rail which has not been control-cooled (normally rolled prior to 1936).

Defects identified and grouped as detail fracture, engine burn fracture, and defective welds, will weaken and also fail in the transverse plane. Detail fractures also fail in the transverse plane and are characteristic of control-cooled rail (usually indicated by the letters CC or CH

on the rail brand, i.e., 1360 RE CC CF&I 1982 1111). Their prescribed remedial action relates to a low range between five and 25 percent and a mid-range between 25 and 80 percent, for note (C) and note (D), respectively. Those defects require joint bar applications and operational speed restrictions within certain time frames. Defects extending less than 100 and between 80 percent require a visual inspection, an elective to restrict operation to a maximum of 10 mph for up to 24 hours, then another visual inspection, if the rail is not replaced, effectively repaired or the track removed from service.

The second paragraph in remedial action note (C) addresses defects which are discovered in Classes 3 through 5 track during an internal rail inspection required under § 213.339, and whose size is determined not to be in excess of 25 percent of the rail head cross-sectional area. For these specific defects, a track owner may operate for a period not to exceed four days, at a speed limited to 50 mph. If the defective rail is not removed or a permanent repair made within four days of discovery, the speed is limited to 30 mph, until joint bars are applied or the rail is replaced.

The requirements specified in this second paragraph are intended to promote better utilization of rail inspection equipment and therefore maximize the opportunity to discover rail defects that are approaching service failure size. The result of FRA's research indicates that defects of this type and size range have a predictable slow growth life. Research further indicates that even on the most heavily utilized trackage in use today, defects of this type and size are unlikely to grow to service failure size in four days.

In the remedial action table, all longitudinal defects are combined within one group subject to identical remedial actions based on their reported size. These types of longitudinal defects all share similar growth rates and the same remedial actions are appropriate to each type.

Defective rails categorized as Horizontal split head, Vertical split head, Split web, Piped rail, and Head-web separation, are longitudinal in nature. When any of this group of defects is more than 1 inch, but not more than 2 inches, the remedial action initiated, under note (H), is to limit train speed to 50 mph, and note (F) require reinspecting the rail in 90 days, if deciding operations will continue. Defects in the range of more than 2 inches, but not more than 4 inches, require complying with notes (I) and (G), speed is limited to 30 mph and the rail reinspected in 30 days, if they decide operations will continue in service. When any of the five defects exceed a length of 4 inches, a person designated under § 213.305(a) must limit the operating speed to 30 mph, under note (B).

Another form of head-web separation, often referred to as a "fillet cracked rail," is the longitudinal growth of a crack in the fillet area, usually on the gage side of the outer rail of a curve. The crack may not extend the full width between the head and the web, but it is potentially dangerous. Evidence of fillet cracking is a hairline crack running beneath the head of rail with "bleeding" or rust discoloration. Fillet cracks often result from improper superelevation or from stress reversal as a result of transposing rail. The use of a mirror is an effective aid in examining rail and the determination of head-web cracks or separation in the body of the rail, extending beyond the joint bar.

A "bolt hole crack" is a progressive fracture originating at a bolt hole and extending away from the hole, usually at an angle. They develop from high-stress risers, usually initiating as a result of both dynamic and thermal responses of the joint bolt and points along the

edge of the hole, under load. A major cause of this high stress is improper field drilling of the hole. Excessive longitudinal rail movement can also cause high stress along the edge of the hole. When evaluating a rail end which has multiple bolt hole cracks, inspectors will determine the required remedial action based on the length of the longest individual bolt hole crack.

Under note (H), the remedial action for a bolt hole crack, more than 1/2-inch but not more than 1-inch, if the rail is not replaced, is to limit speed to 50 mph then reinspect the rail in 90 days, if operations will continue in service. Cracks discovered greater than 1-inch, but not exceeding 1-1/2 inches, should be reinspected within 30 days and the speed limited to 50 mph. For a bolt hole crack exceeding 1-1/2 inches, a person qualified under § 213.305(a) may elect to designate a speed restriction, but cannot exceed 30 mph.

Where corrective action requires rail to be reinspected within a specific number of days after discovery, the track owner may exercise several options for compliance. One option would be to perform another inspection with rail flaw detection equipment, either rail-mounted or hand-held. Another option would be to perform a visual inspection where the defect is visible and measurable. In the latter case, for certain defects enclosed within the joint bar area such as bolt hole breaks, removal of the joint bars will be necessary to comply with the reinspection requirement. If defects remain in track beyond the reinspection interval, the railroad must continue to monitor the defect and take the appropriate action as required in the remedial action table.

A broken base can result from improper bearing of the base on a track spike or tie plate shoulder, from over-crimped anchors, or it may originate in a manufactured seam. With today's higher axle loads, inspectors can anticipate broken base defects in 75-pound and smaller rail sections with an irregular track surface, especially on the field side. For any broken base discovered that is more than 1 inch but less than 6 inches in length, the remedial action (note D) is to apply joint bars bolted through the outermost holes to defect within 10 days, if operations will continue. The operating speed must be reduced to 30 mph or less, as authorized by a person under § 213.305(a), until joint bars are applied. After that, operating speed is limited to 50 mph.

A broken base in excess of 6 inches requires the assignment of a person designated under § 213.305 to visually supervise each train operation over the defective rail. The railroad may apply joint bars to the defect and bolt them in accordance with § 213.351(d) and (e) and thereafter must limit train operations to 30 mph. As reference, the dimensions between the outermost holes of a 24-inch joint bar vary between approximately 15 and 18 inches and a 36-inch joint bar approaches 30 inches.

Inspectors should point out to the track owner that broken bases nearing these dimensions and originating in track, may negate the purpose for which the joint bars are applied. A broken base rail may be caused by damage from external sources, such as rail anchors being driven through the base by a derailed wheel. It is improper to consider them "damaged rail," as this defect is addressed by more stringent provisions applicable to broken base rail, under note (A) or (E) and (I).

Damaged rail can result from flat or broken wheels, incidental hammer blows, or derailed or dragging equipment. Reducing the operational speed to 30 mph until joint bars are

applied, lessens the impact force imparted to the weakened area. Applying joint bars under note (D) insures a proper horizontal and vertical rail-end alignment in the event the rail fails.

Flattened rails (localized collapsed head rail) are also caused by mechanical interaction from repetitive wheel loadings. FRA and industry research indicate that these occurrences are more accurately categorized as rail surface conditions, not rail defects, as they do not, in themselves, cause service failure of the rail. Although it is not a condition shown to affect the structural integrity of the rail section, it can result in less-than-desirable dynamic vehicle responses in the higher speed ranges. The flattened rail condition is identified in the table, as well as in the definition portion of § 213.337(b), as being 3/8-inch or more in depth below the rest of the railhead and 8 inches or more in length. As the defect becomes more severe by reducing railhead depth and width size, wheel forces increase. If located either on the outside or inside rail, the limited cross-sectional area of the rail may increase the lateral-to-vertical ratio and cause a wheel-lift condition. The rule addresses the issue of “flattened rail” in terms of a specified remedial action for those of a certain depth and length. Those locations meeting the depth and length criteria shall be limited to an operating speed of 50 mph or the maximum allowable under § 213.307 for the class of track concerned, whichever is lower.

A “break out in rail head” is defined as a piece which has physically separated from the parent rail. Rail defects meeting this definition are required to have each operation over that rail visually supervised by a person designated under § 213.305(a). Inspectors need to be aware that this definition has applicability across a wide range of rail defects, as indicated in the remedial action table. Where rail defects which have not progressed to the point where they meet this strict definition, but due to the type, length and location of the defect present a hazard to continued train operation, inspectors should determine what remedial actions, if any, are to be instituted by the track owner

The issue of “excessive rail wear” continues to be evaluated by FRA’s rail integrity research program. FRA believes that insufficient data exists at this time to indicate that parameters for this condition should be proposed as a minimum standard.

Inspectors are expected to be conversant with rail defect types, appearance, growth, hazards, and methods of detection. There are publications on rail defects, which can be used for reference (for example, the Rail Defect Manual compiled by Sperry Rail Service).

**Defect Codes**

0337A	Operation continued over defective rail without required remedial action.
0337B	Rail defect originating from bond wire attachment
0337B2	Compound fissure
0337B3	Horizontal split head
0337B4	Vertical split head
0337B5	Split web
0337B6	Piped rail
0337B7	Broken base
0337B8	Detail fracture

0337B9	Engine burn fracture
0337B10	Ordinary break
0337B11	Damaged rail
0337B12	Flattened rail
0337B13	Bolt-hole crack
0337B14	Broken or defective weld
0337B15	Head web separation

**§ 213.339 Inspection of rail in service**

339(a) *A continuous search for internal defects shall be made of all rail in track at least twice annually with not less than 120 days between inspections*

339(b) *Inspection equipment shall be capable of detecting defects between joint bars, in the area enclosed by joint bars.*

339(c) *Each defective rail shall be marked with a highly visible marking on both sides of the web and base.*

339(d) *If the person assigned to operate the rail defect detection equipment being used determines that, due to rail surface conditions, a valid search for internal defects could not be made over a particular length of track, the test on that particular length of track cannot be considered as a search for internal defects under paragraph (a) of this section.*

339(e) *If a valid search for internal defects cannot be conducted for reasons described in paragraph (d) of this section, the track owner shall, before the expiration of time limits --*

- (1) *Conduct a valid search for internal defects;*
- (2) *Reduce operating speed to a maximum of 25 mph until such time as a valid search for internal defects can be made; or*
- (3) *Remove the rail from service.*

**Guidance:** A continuous search for internal rail defects must be made of all rail in track classes 6, 7, 8, and 9 at a frequency of twice annually with a minimum of 120 days interval between inspections.

If a valid search for internal defects cannot be conducted because of surface conditions such as shells, head checks, etc. or lubrication or similar conditions, the inspection is not considered an inspection for the purposes of this section. The railroad must reduce operating speed to 25 mph until the valid search is made or the rail is removed from service.

**Defect Codes**

0339A	Failure to inspect rail for internal defects at required frequency.
0339B	Failure of equipment to inspect rail at joints.
0339C	Defective rail not marked properly.
0339E2	Failure to reduce operating speed until valid rail inspection is performed.

**§ 213.341 Initial Inspection of new rail and welds**

*The track owner shall provide for the initial inspection of newly manufactured rail, and for initial inspection of new welds made in either new or used rail. A track owner may demonstrate compliance with this section by providing for:*

- 341(a) In-service inspection -- A scheduled periodic inspection of rail and welds that have been placed in service, if conducted in accordance with the provisions of § 213.339, and if conducted not later than 90 days after installation, shall constitute compliance with paragraphs (b) and (c) of this section;*
- 341(b) Mill inspection -- A continuous inspection at the rail manufacturer's mill shall constitute compliance with the requirement for initial inspection of new rail, provided that the inspection equipment meets the applicable requirements specified in § 213.339. The track owner shall obtain a copy of the manufacturer's report of inspection and retain it as a record until the rail receives its first scheduled inspection under § 213.339;*
- 341(c) Welding plant inspection -- A continuous inspection at a welding plant, if conducted in accordance with the provisions of paragraph (b) of this section, and accompanied by a plant operator's report of inspection which is retained as a record by the track owner, shall constitute compliance with the requirements for initial inspection of new rail and plant welds, or of new plant welds made in used rail; and*
- 341(d) Inspection of field welds -- An initial inspection of field welds, either those joining the ends of CWR strings or those made for isolated repairs, shall be conducted not less than one day and not more than 30 days after the welds have been made. The initial inspection may be conducted by means of portable test equipment. The track owner shall retain a record of such inspections until the welds receive their first scheduled inspection under § 213.339.*
- 341(e) Each defective rail found during inspections conducted under paragraph (a) or (d) of this section shall be marked with highly visible markings on both sides of the web and base and the remedial action as appropriate under § 213.337 will apply.*

**Guidance:** The railroad must provide initial inspections of newly manufactured rail and initial inspections of new welds made in either new or used rail.

To comply with the requirement to inspect newly manufactured rail, the railroad may conduct an in-service inspection, if conducted in accordance with § 213.339, within 90 days after installation; or

To comply with the requirement to inspect newly manufactured rail, the railroad may elect to conduct a continuous inspection at the rail manufacturer's mill provided that the inspection equipment meets the requirements of § 213.339.

If the mill inspection option is selected, the railroad shall maintain a record of the inspection as specified in this section.

Similarly, the railroad is required to inspect new welds made in new or used rail, either at the plant or in the track.

Each defective rail found under this section must be clearly marked and the proper remedial action taken. Inspector should cite the appropriate defect code in § 213.339 for the type of rail defect found.

**Defect Codes**

0341B	Failure to conduct initial inspection of new rail.
0341C	Failure to inspect new welds made in new or used rail.
0341E	Failure to clearly mark rail defect found during initial inspection of new rail and welds.

**§ 213.343 Continuous welded rail (CWR)**

*Each track owner with track constructed of CWR shall have in effect written procedures which address the installation, adjustment, maintenance and inspection of CWR, and a training program for the application of those procedures, which shall be submitted to the Federal Railroad Administration within six months following the effective date of this rule. FRA reviews each plan for compliance with the following --*

*343(a) Procedures for the installation and adjustment of CWR which include --*

- (1) Designation of a desired rail installation temperature range for the geographic area in which the CWR is located; and*
- (2) De-stressing procedures/methods which address proper attainment of the desired rail installation temperature range when adjusting CWR.*

*343(b) Rail anchoring or fastening requirements that will provide sufficient restraint to limit longitudinal rail and crosstie movement to the extent practical, and specifically addressing CWR rail anchoring or fastening patterns on bridges, bridge approaches, and at other locations where possible longitudinal rail and crosstie movement associated with normally expected train-induced forces, is restricted.*

*343(c) Procedures which specifically address maintaining a desired rail installation temperature range when cutting CWR including rail repairs, in-track welding, and in conjunction with adjustments made in the area of tight track, a track buckle, or a pull-apart. Rail repair practices shall take into consideration existing rail temperature so that --*

- (1) When rail is removed, the length installed shall be determined by taking into consideration the existing rail temperature and the desired rail installation temperature range; and*
- (2) Under no circumstances should rail be added when the rail temperature is below that designated by paragraph (a)(1) of this section, without provisions for later adjustment.*

*343(d) Procedures which address the monitoring of CWR in curved track for inward shifts of alignment toward the center of the curve as a result of disturbed track.*

*343(e) Procedures which control train speed on CWR track when --*



(1) *Maintenance work, track rehabilitation, track construction, or any other event occurs which disturbs the roadbed or ballast section and reduces the lateral and/or longitudinal resistance of the track; and*

(2) *In formulating the procedures under this paragraph (e), the track owner shall--*

(i) *Determine the speed required, and the duration and subsequent removal of any speed restriction based on the restoration of the ballast, along with sufficient ballast re-consolidation to stabilize the track to a level that can accommodate expected train-induced forces. Ballast re-consolidation can be achieved through either the passage of train tonnage or mechanical stabilization procedures, or both; and*

(ii) *Take into consideration the type of crossties used.*

343(f) *Procedures which prescribe when physical track inspections are to be performed to detect buckling prone conditions in CWR track. At a minimum, these procedures shall address inspecting track to identify --*

(1) *Locations where tight or kinky rail conditions are likely to occur;*

(2) *Locations where track work of the nature described in paragraph (e)(1) of this section have recently been performed; and*

(3) *In formulating the procedures under this paragraph (f), the track owner shall --*

(i) *Specify the timing of the inspection; and*

(ii) *Specify the appropriate remedial actions to be taken when buckling prone conditions are found.*

343(g) *The track owner shall have in effect a comprehensive training program for the application of these written CWR procedures, with provisions for periodic re-training, for those individuals designated under § 213.305(c) of this part as qualified to supervise the installation, adjustment, and maintenance of CWR track and to perform inspections of CWR track.*

343(h) *The track owner shall prescribe recordkeeping requirements necessary to provide an adequate history of track constructed with CWR. At a minimum, these records shall include:*

(1) *Rail temperature, location and date of CWR installations. This record shall be retained for at least one year; and*

(2) *A record of any CWR installation or maintenance work that does not conform with the written procedures. Such record shall include the location of the rail and be maintained until the CWR is brought into conformance with such procedures.*

343(i) *As used in this section --*

(1) *“Adjusting/De-stressing” means the procedure by which a rail’s temperature is re-adjusted to the desired value. It typically consists of cutting the rail and removing rail anchoring devices, which provides for the necessary expansion and contraction, and then re-assembling the track.*

(2) *“Buckling Incident” means the formation of a lateral mis-alignment sufficient in magnitude to constitute a deviation of 5 inches measured with a 62-foot chord. These normally occur when rail temperatures are relatively high and are caused by high longitudinal compressive forces.*

- (3) *“Continuous Welded Rail (CWR)” means rail that has been welded together into lengths exceeding 400 feet.*
- (4) *“Desired Rail Installation Temperature Range” means the rail temperature range, within a specific geographical area, at which forces in CWR should not cause a buckling incident in extreme heat, or a pull-apart during extreme cold weather.*
- (5) *“Disturbed Track” means the disturbance of the roadbed or ballast section, as a result of track maintenance or any other event, which reduces the lateral or longitudinal resistance of the track, or both.*
- (6) *“Mechanical Stabilization” means a type of procedure used to restore track resistance to disturbed track following certain maintenance operations. This procedure may incorporate dynamic track stabilizers or ballast consolidators, which are units of work equipment that are used as a substitute for the stabilization action provided by the passage of tonnage trains.*
- (7) *“Rail Anchors” means those devices which are attached to the rail and bear against the side of the crosstie to control longitudinal rail movement. Certain types of rail fasteners also act as rail anchors and control longitudinal rail movement by exerting a downward clamping force on the upper surface of the rail base.*
- (8) *“Rail Temperature” means the temperature of the rail, measured with a rail thermometer.*
- (9) *“Tight/Kinky Rail” means CWR which exhibits minute alignment irregularities which indicate that the rail is in a considerable amount of compression.*
- (10) *“Train-induced Forces” means the vertical, longitudinal, and lateral dynamic forces which are generated during train movement and which can contribute to the buckling potential.*
- (11) *“Track Lateral Resistance” means the resistance provided to the rail/crosstie structure against lateral displacement.*
- (12) *“Track Longitudinal Resistance” means the resistance provided by the rail anchors/rail fasteners and the ballast section to the rail/crosstie structure against longitudinal displacement.*

343(j) *Track owners shall revise their CWR plans to include provisions for the inspection of joint bars in accordance with §§213.119(g) and (i)(3).*

**Guidance:** The definition “buckling incident” is provided to explain the industry-accepted threshold for such an event. However, the rule recognizes the importance of conditions that are precursors to buckles.

Paragraph (a) requires the railroad to have in effect and comply with their own written procedures that address the installation, adjustment, maintenance and inspection of CWR.

The written procedures should be reasonable and consistent with current research results. FRA will review each plan for compliance with paragraphs (a) through (f). The FRA Headquarters track specialists and Regional track specialists shall have primary responsibility for reviewing each set of railroad CWR procedures. Inspectors may be requested to provide recommendations concerning the comprehensiveness of those procedures.

In addition to safety critical procedures listed in this section, the railroad may decide to include procedures based on administrative or economic considerations. For example, a railroad may choose to include instructions that limit the use of worn secondhand

replacement rail because of an economic concern about the length of time that it might take to perform a satisfactory weld. The railroad may also include specific actions in their procedures that are to be taken when installation or maintenance work does not comply with its overall procedures.

The railroad must record the location of any installation or maintenance work in CWR that does not conform to its procedures in accordance with Section 213.343(h)(2). The record shall be maintained until the CWR is brought into conformance with the railroad's written procedures. The railroad may also wish to include a narrative explanation of the special circumstances involved. Inspectors should periodically review the information recorded in accordance with § 213.343(h)(2) to determine if any work performed on CWR, which does not comply with the railroad procedures, is being properly recorded.

Inspectors must be aware of the procedures in effect before inspecting each railroad. When conducting inspections, the inspector must make observations to determine if the railroad is following its basic safety procedures. If the railroad fails to follow its procedures and the failure may lead to a serious safety problem, the inspector should consider citing the railroad for failure to comply with their CWR procedures. A violation memorandum must document the circumstances involved, including whether or not the railroad recorded the conditions as required under § 213.343(h)(2). However, the inspector should exercise judgment in the reporting of circumstances that do not fully comply with the written procedures. Minor deviations from written CWR procedures should not be considered for enforcement action unless, together with other violations, they are part of a larger safety problem.

Merely recording an activity which does not conform to the railroad's CWR procedures does not provide the railroad with indefinite relief from responsibility for compliance when its procedures are not followed and continued noncompliance may lead to an unsafe condition. The recordkeeping procedure is intended to provide a safety net by flagging those activities of noncompliance, which if not brought into compliance in a timely manner, could lead to an unsafe condition. For example, CWR track installed in the winter months without adequate rail anchors as prescribed by the written procedures and discovered in late summer would clearly be a deficient condition, whether it was recorded or not. When in doubt as to what activities are considered safety-related, the inspector should consult with the regional track specialist.

Under guidance from the regional track specialist, inspectors must determine the adequacy of the railroad's formal training program under § 213.343(g) and (h). Those training procedures are required to be consistent and current with research results, clear, concise, and easy to understand by maintenance-of-way employees.

Railroads typically establish a desired rail installation temperature range for the geographical area that is higher than the annual mean temperature. This higher installation temperature will account for the expected reduction of the force-free temperature caused by track maintenance, train traffic and other factors. A railroad's failure to establish a designated installation temperature range for a specific territory is addressed under § 213.343(a).

The two failure modes associated with track constructed with CWR are track buckles and a pull-aparts. A track buckle is considered the more serious of the two and is characterized by the formation of a large lateral mis-alinement caused by:

- high compressive forces in the rail (thermal and mechanical loads);
- weakened track conditions (weak track resistance, alinement deviations); and
- vehicle loads (a dynamic “wave” uplift and lateral vs. vertical ratios).

Thermal and mechanical loads are opposed by three parameters: lateral, longitudinal, and torsional resistance of the track. Track buckles almost always occur in the lateral direction. Lateral resistance is the most important and is dependent upon weight and size of crosstie material, ballast material type, shoulder width, crib content and the level of consolidation, and vertical loads.

A crosstie’s base, side (crib) friction and ballast shoulder resistance contribute to the overall lateral resistance sustained. In general, each contributes (base 50%, side 20-30%, and shoulder 20-30%) to this resistance but the ratios can vary depending on ballast condition. Lateral resistance varies in location depending on the ballast shoulder geometry, crosstie size and type, and state of ballast consolidation.

Thermal loads by themselves can cause a buckle and are often called “static buckling.” Most buckling, however, occurs under a combination of thermal and vehicle loads, termed “dynamic buckling.” Inspectors should place emphasis on vehicle (dynamic) effects on track lateral stability, where high rail temperatures and vehicle loading could progressively weaken the track due to dynamic uplift (flexural waves) and a buckle mechanism response induced by misalignment “growth.”

Because the majority of buckles occur under dynamic train movements, loading is an important element in the buckling mechanism. Elements of track lateral instability include:

- formation of initial track misalinements caused by reduced local resistance;
- high impact loads, initial rail surface (weld) imperfections and ‘soft’ spots in ballast, and curve (radial breathing) shifting; and
- misalignment growth caused by high lateral loads, increased longitudinal forces, track uplifts due to vertical loads, and train induced vibration.

Inspectors may consider the above elements combined with related evidence of actual or incipient geometry defects or other defective structural conditions when evaluating the adequacy of a railroad’s CWR stability procedures (or lack thereof) under § 213.343(b), (c), and (d). Locations where imminent track buckling is more likely to occur include: horizontal and vertical curves, bottom of grades, bridge approaches, highway-rail grade crossings, recently disturbed track, and areas of heavy train starting or braking.

The signs or precursors of buckles include:

- newly formed alinement deviations; wavy, kinky, snaky, etc.,
- minute rail alinement;
- rails rotating or lifting out of the tie plates and intermittent loose tie plates;
- excessive “running” rail causing ties to plow or churn the ballast;
- insufficient and moving anchors;
- insufficient ballast section in the crib and shoulder areas;

- gaps at crosstie ends, especially on the low (inner) rail; and
- previous buckles improperly repaired.

Curves are more prone to buckling because of the curvature effect, alinement imperfection sensitivity, and train loads. It is important for inspectors to consider when and where a buckle may occur, e.g., on track segments where the CWR was laid “cold” below the desired rail installation temperature range and there was inadequate control of the laying temperature or inadequate adjustment of the rail afterwards. Also, inspectors should observe areas of recent maintenance involving either ballast or rail, where there was inadequate reconsolidating time for disturbed ballast or inadequate temperature adjustment when replacing a defective rail. As curvature increases, the buckling resistance decreases. Under some conditions, high degree curvature can undergo gradual lateral shift (progressive buckling). Lateral alinement deviations reduce the track buckling strength and can initiate growth to critical levels. Vertical alinement deviations can also influence buckling.

Lateral mis-alinement is an important consideration and it influences buckling strength significantly. An alinement offset or mid-ordinate within allowable limits may “grow” under the imposed loads, the ballast, subgrade movement and settlement. This is called “track shift.” A longitudinal force in curved track will cause CWR rail to move radially. Compressive loads in the rail during the summer tend to move the track outwards and tensile loads in the winter will pull the track inward, a term known as “radial breathing.” Inspectors should review the allowable limits, under § 213.327, and evaluate the relevant alinement and track strength (§ 213.311, movement under load) due to repeated thermal and vehicle loadings.

Generally speaking, a decrease in the force-free temperature of 30 to 40 degrees from the installation temperature can be critical and lead directly to buckling. Inspectors should monitor the following factors which may influence shifts in the force-free temperature: improper rail installation, inadequate rail anchors or fastenings, lateral movements in curves through lining operations, “skeletonized” track segments, and inadequate ballast section. Lateral and longitudinal restraint is influenced by the factors mentioned above and, if improperly executed or allowed to exist in a defective state, may produce a potential track buckle.

Tangent track buckling incidents are less frequent than in curves. However, buckling in tangent track will generally occur suddenly and with more severe consequences.

The second of the two failure modes can be associated with track constructed with CWR is a pull-apart. A rail’s decrease in temperature in the winter will create tensile forces. The maximum tensile load in the rail is determined by the difference in the installation or force-free temperature and the lowest rail temperatures. Enough tensile force can cause direct fracture at rail cross-sections with prior cracks, weak welds or shear joint bolts at CWR string end locations.

A track owner may update or modify CWR procedures as necessary, upon notification to FRA of those changes.

**Defect Code**

0343Aj <sup>1</sup>	Failure of track owner to develop and implement written CWR procedures.
0343Aii <sup>1</sup>	Failure to comply with written CWR procedures.
0343G	Failure of track owner to develop a training program for the implementation of their written CWR procedures.
0343H	Failure to keep CWR records as required.
0343J	Failure to revise CWR plan to include provisions for the inspection of joint bars in accordance with §§ 213.119(g) and (h(1 )through (6).

1. The code does not match 213.343(a). It corresponds to the opening paragraph.

**§ 213.345 Vehicle/track system qualification.**

**General Guidance to § 213.345:** The 1998 Track Safety Standards final rule requires that all (passenger and freight) rolling stock be qualified for operation for its intended track class. Qualification testing was intended to demonstrate that the equipment not exceed the VTI limits specified in § 213.333 at any speed less than 10 m.p.h. above the proposed maximum operating speed. An exception was provided for equipment that had already operated in specified track classes. Rolling stock operating in Class 6 track within one year prior to the promulgation of the 1998 final rule was considered qualified. Further, vehicles operating at Class 7 track speeds under conditional waivers prior to the promulgation of the 1998 final rule were qualified for Class 7 track, including equipment that was then-operating on the Northeast Corridor at Class 7 track speeds.

A number of significant changes were made to this section. The heading is modified from “Vehicle qualification testing” to “Vehicle/track system qualification,” to reflect more appropriately the interaction of the vehicle and the track over which it operates as a system. Changes in the text include modifying and clarifying this section’s substantive requirements, reorganizing the structure and layout of the rule text, and revising the qualification procedures. Among the specific changes, high cant deficiency operations on lower-speed track classes are subject to the requirements of this section in accordance with § 213.57(i).

All requirements contained in paragraphs 345(a)–(d) are summarized in the following table for quick reference:

**Vehicle/Track System Qualification Reference Chart**

Cant Deficiency $E_u$ (in)	New Vehicle Type									Qualified Vehicle Type								
	Track Class & Maximum Allowable Operating Speed (m.p.h.)																	
	1	2	3	4	5	6	7	8	9	1	2	3	4	5	6	7	8	9
	15 (10) <sup>1</sup>	30 (25)	60 (40)	80 (60)	90 (80)	110	125 5	160	220	15 (10)	30 (25)	60 (40)	80 (60)	90 (80)	110	125	160	220
$E_u \leq 3$	No Testing or Simulations					$A_C + A_T + (W \text{ or } S)$	$A_C + A_T + W + S$			No Testing or Simulations					$A_C + A_T$			
$3 < E_u \leq 5$	L					L + $A_C$ + $A_T$ +(W or S)	L + $A_C$ + $A_T$ + W + S			N					$N + A_C + A_T$			
$5 < E_u \leq 6$	L + $A_C$									N + $A_C$					$N + A_C + A_T + (W \text{ or } S)$			
$E_u > 6$	L + $A_C + W + S$								N + $A_C + (W \text{ or } S)$									
$A_C$ = Car body accelerations $A_T$ = Truck accelerometers $L^2$ = Lean test $N^3$ = FRA Notification $S$ = Simulation (MCAT & Segment) $W$ = Wheel-Rail force measurement																		

- Numbers in parentheses are max allowable operating speed for freight trains
- Lean test requirements may be met by static or dynamic testing (W+A), see sections 213.57(d) & 213.329(d)
- See sections 213.57(h) & 213.329(h)

*345(a) General. All vehicle types intended to operate at track Class 6 speeds or above, or at any curving speed producing more than 5 inches of cant deficiency, shall be qualified for operation for their intended track classes in accordance with this subpart. A qualification program shall be used to demonstrate that the vehicle/track system will not exceed the wheel/rail force safety limits and the carbody and truck acceleration criteria specified in § 213.333—*

- (1) At any speed up to and including 5 m.p.h. above the proposed maximum operating speed; and*
- (2) On track meeting the requirements for the class of track associated with the proposed maximum operating speed. For purposes of qualification testing, speeds may exceed the maximum allowable operating speed for the class of track in accordance with the test plan approved by FRA.*

**Guidance:** Paragraph (a) specifies criteria for vehicle types to be qualified for operation.

Paragraph (a)(1) specifies that for qualification purposes, the over-speed testing requirement can be 5 m.p.h. above the maximum proposed operating speed.

Paragraph (a)(2) clarifies that for purposes of qualification testing, speeds may exceed the maximum allowable operating speeds for the class of track in accordance with the test plan approved by FRA. This eliminates any potential needs for a Rule of Particular Applicability (RPA) to allow qualification testing above the maximum speeds proposed for the operation. Upon FRA's approval of the qualification test plan, testing at such speeds conducted in accordance with this plan is deemed in compliance with this part 213. This paragraph become applicable if the speed is the maximum class speed, e.g. 110 m.p.h. for class 6. With the 5 m.p.h. allowance as provided in paragraph (a)(1), the testing speed will fall into class 7. This is allowable for test purpose by this paragraph.

Note that for operations on Class 1 through 5 track at curving speeds producing more than 5 inches of cant deficiency, the 5 m.p.h. above the proposed maximum operating speed, in combination with track class and curvature and elevation, could result in a cant deficiency more than 3 inches above the proposed maximum cant deficiency. Should this happen, the lesser speed of 5 m.p.h. over the proposed maximum operating speed would apply.

*345(b) Existing vehicle type qualification. Vehicle types previously qualified or permitted to operate at track Class 6 speeds or above or at any curving speeds producing more than 5 inches of cant deficiency prior to March 13, 2013, shall be considered as being successfully qualified under the requirements of this section for operation at the previously operated speeds and cant deficiencies over the previously operated track segment(s).*

**Guidance:** This paragraph addresses the portability of previously qualified vehicle types. The portability provision is applicable to 1) track Class 6 speeds or above; or 2) cant deficiency of 5 inches regardless of speed; and 3) previously operated track segment(s) only.

To qualify such vehicle types to operate over new routes (even at the same track speeds), the qualification requirements contained in other paragraphs of this section must be met.

*345(c) New vehicle type qualification. Vehicle types not previously qualified under this subpart shall be qualified in accordance with the requirements of this paragraph (c).*

- (1) Simulations or measurement of wheel/rail forces. For vehicle types intended to operate at track Class 6 speeds, simulations or measurement of wheel/rail forces during qualification*



*testing shall demonstrate that the vehicle type will not exceed the wheel/rail force safety limits specified in § 213.333. Simulations, if conducted, shall be in accordance with paragraph (c)(2) of this section. Measurement of wheel/rail forces, if conducted, shall be performed over a representative segment of the full route on which the vehicle type is intended to operate.*

- (2) *Simulations. For vehicle types intended to operate at track Class 7 speeds or above, or at any curving speed producing more than 6 inches of cant deficiency, analysis of vehicle/track performance (computer simulations) shall be conducted using an industry recognized methodology on:
  - (i) *An analytically defined track segment representative of minimally compliant track conditions (MCAT—Minimally Compliant Analytical Track) for the respective track class(es) as specified in appendix D to this part; and*
  - (ii) *A track segment representative of the full route on which the vehicle type is intended to operate. Both simulations and physical examinations of the route's track geometry shall be used to determine a track segment representative of the route.**
- (3) *Carbody acceleration. For vehicle types intended to operate at track Class 6 speeds or above, or at any curving speed producing more than 5 inches of cant deficiency, qualification testing conducted over a representative segment of the route shall demonstrate that the vehicle type will not exceed the carbody lateral and vertical acceleration safety limits specified in § 213.333.*
- (4) *Truck lateral acceleration. For vehicle types intended to operate at track Class 6 speeds or above, qualification testing conducted over a representative segment of the route shall demonstrate that the vehicle type will not exceed the truck lateral acceleration safety limit specified in § 213.333.*
- (5) *Measurement of wheel/rail forces. For vehicle types intended to operate at track Class 7 speeds or above, or at any curving speed producing more than 6 inches of cant deficiency, qualification testing conducted over a representative segment of the route shall demonstrate that the vehicle type will not exceed the wheel/rail force safety limits specified in § 213.333.*

**Guidance:** Paragraph (c) contains the requirements for qualifying new vehicle types and references § 213.333 for the applicable VTI limits for accelerations and wheel/rail forces.

Paragraph (c)(1) allows for vehicle types intended to operate at track Class 6 speeds to be qualified either through simulations or the use of IWS to demonstrate compliance with the wheel/rail force limits specified in § 213.333. It makes clear that computer simulations are an alternative to IWS and does not eliminate use of IWS testing. If opted, simulations must be conducted in accordance with paragraph (c)(2). Note that validation of simulations results needs not be done prior to the qualification testing, but can be done during/after the qualification test, using data from the test.

Paragraph (c)(2) requires computer simulations for new vehicle types intended to operate at track Class 7 speeds or above, as well at any curving speed producing more than 6 inches of cant deficiency. This requirement is additional to IWS as specified in (c)(5).

Note that, although in accordance with § 213.57(i), vehicle types intended to operate at cant deficiencies greater than 5 inches on the track Classes 1-5 are subject to the requirements of this section, the requirements of this paragraph (c)(2) apply only to operations at cant deficiencies greater than 6 inches on these classes.

This paragraph (c)(2) requires computer simulations to be conducted on both an analytically defined track segment representative of minimally compliant track conditions (MCAT) for the respective track classes as specified in appendix D, and on a track segment representative of the full route on which the vehicle type is intended to operate (See the guidance for MCAT in appendix D.)

Paragraph (c)(3) requires carbody acceleration testing for all operations at track Class 6 speeds or above, or for any operation above 5 inches of cant deficiency. Note that, in accordance with § 213.57(i), vehicle types intended to operate at cant deficiencies greater than 5 inches on Class 1-5 track are subject to these requirements.

Paragraph (c)(4) requires truck acceleration testing for all operations at track Class 6 speeds or above.

Paragraph (c)(5) requires measurement of wheel/rail forces, through the use of IWS (or equivalent devices) for all operations at track Class 7 speeds or above, or for any operation above 6 inches of cant deficiency. Again, the requirements of paragraph (c)(5) apply to Class 1–5 track only for operations at cant deficiencies greater than 6 inches.

*345(d) Previously qualified vehicle types. Vehicle types previously qualified under this subpart for a track class and cant deficiency on one route may be qualified for operation at the same class and cant deficiency on another route through analysis or testing, or both, to demonstrate compliance with paragraph (a) of this section in accordance with the following:*

- (1) Simulations or measurement of wheel/rail forces. For vehicle types intended to operate at any curving speed producing more than 6 inches of cant deficiency, or at curving speeds that both correspond to track Class 7 speeds or above and produce more than 5 inches of cant deficiency, simulations or measurement of wheel/rail forces during qualification testing shall demonstrate that the vehicle type will not exceed the wheel/rail force safety limits specified in § 213.333. Simulations, if conducted, shall be in accordance with paragraph (c)(2) of this section. Measurement of wheel/rail forces, if conducted, shall be performed over a representative segment of the new route.*
- (2) Carbody acceleration. For vehicle types intended to operate at any curving speed producing more than 5 inches of cant deficiency, or at track Class 7 speeds and above, qualification testing conducted over a representative segment of the new route shall demonstrate that the vehicle type will not exceed the carbody lateral and vertical acceleration safety limits specified in § 213.333.*
- (3) Truck lateral acceleration. For vehicle types intended to operate at track Class 7 speeds or above, measurement of truck lateral acceleration during qualification testing shall demonstrate that the vehicle type will not exceed the truck lateral acceleration safety limits specified in § 213.333. Measurement of truck lateral acceleration, if conducted, shall be performed over a representative segment of the new route.*

**Guidance:** Paragraph (d) contains the qualification requirements and provisions for portability for prequalified vehicle intended to operate on new track routes.

Although the vehicle type may remain unchanged, the vehicle/track system still needs to be appropriately examined for deficiencies prior to its service operation on a new route where performance-based standards are relied upon at track Class 7 speeds or above and at cant deficiencies exceeding 5 inches. This seemed to be supported by past experience with the

high-speed and high cant deficiency qualification of the Acela trainset where testing at a well-maintained Class 8 test track did not uncover performance issues that were later identified during the local vehicle/track system testing on the Northeast Corridor. It is therefore considered necessary that new vehicle/track system be examined during qualification testing to demonstrate system safety.

Paragraph (d)(1) provides that for all operations at track Class 7 speeds or above and cant deficiencies exceeding 5 inches, or for any operation above 6 inches of cant deficiency, simulations or measurements of wheel/rail forces are required to demonstrate safe, local vehicle/track system performance on a new route. For performance-based standards that address the vehicle/track system, simulations are especially useful for demonstrating that when qualified vehicles are intended to operate on a new route, the new vehicle/track system is adequately examined for deficiencies prior to revenue service operation. It is noted that, once simulated over the MCAT deviations, a fully-validated vehicle model required for qualifying new vehicle types under this final rule need not be repeated. Only a simulation for a representative track segment from the new route is required, as the results of the MCAT simulations will be kept on file and be available for reference.

Paragraph (d)(1) specifies the requirements for carbody accelerations testing for vehicle types intended to operate cant deficiency above 5 inches but not exceeding 6 inches for operations at track Class 1 through 6 speeds. The testing is to demonstrate safe, local vehicle/track system performance on a new route.

Paragraph (d)(3) states that for previously qualified vehicle types intended to operate on new routes at track Class 7 speeds or above, truck acceleration testing is required to demonstrate safe, local vehicle/track system performance.

*345(e) Qualification testing plan. To obtain the data required to support the qualification program outlined in paragraphs (c) and (d) of this section, the track owner or railroad shall submit a qualification testing plan to FRA's Associate Administrator for Railroad Safety/Chief Safety Officer (FRA) at least 60 days prior to testing, requesting approval to conduct the testing at the desired speeds and cant deficiencies. This test plan shall provide for a test program sufficient to evaluate the operating limits of the track and vehicle type and shall include:*

- (1) Identification of the representative segment of the route for qualification testing;*
- (2) Consideration of the operating environment during qualification testing, including operating practices and conditions, the signal system, highway-rail grade crossings, and trains on adjacent tracks;*
- (3) The maximum angle found on the gage face of the designed (newly-profiled) wheel flange referenced with respect to the axis of the wheelset that will be used for the determination of the Single Wheel L/V Ratio safety limit specified in § 213.333;*
- (4) A target maximum testing speed in accordance with paragraph (a) of this section and the maximum testing cant deficiency;*
- (5) An analysis and description of the signal system and operating practices to govern operations in track Classes 7 through 9, which shall include a statement of sufficiency in these areas for the class of operation; and*
- (6) The results of vehicle/track performance simulations that are required by this section.*

**Guidance:** Paragraph (e) clarifies the requirements for the content of the qualification testing plan and adds a requirement for the plan to be submitted to FRA at least 60 days

prior to conducting the testing.

The paragraph requires that the test plan:

- Identifies the test track segment representative of the route ((e)(1)).
- Identifies the maximum angle found on the gage face of the designed (newly profiled) wheel flange referenced with respect to the axis of the wheelset ((e)(3)).
- Identifies the target maximum testing speed in accordance with paragraph (a) of this section and the maximum testing cant deficiency ((e)(4)).

The maximum testing speed will be the maximum allowable operating speed + 5 m.p.h. and the maximum testing cant deficiency will be that intended to achieve during qualification testing.

- Includes the results of vehicle/track performance simulations ((e)(6)).

*345(f) Qualification testing. Upon FRA approval of the qualification testing plan, qualification testing shall be conducted in two sequential stages as required in this subpart.*

- (1) *Stage-one testing shall include demonstration of acceptable vehicle dynamic response of the subject vehicle as speeds are incrementally increased—*
  - (i) *On a segment of tangent track, from acceptable track Class 5 speeds to the target maximum test speed (when the target speed corresponds to track Class 6 and above operations); and*
  - (ii) *On a segment of curved track, from the speeds corresponding to 3 inches of cant deficiency to the maximum testing cant deficiency.*
- (2) *When stage-one testing has successfully demonstrated a maximum safe operating speed and cant deficiency, stage-two testing shall commence with the subject equipment over a representative segment of the route as identified in paragraph (e)(1) of this section.*
  - (i) *A test run shall be conducted over the route segment at the speed the railroad will request FRA to approve for such service.*
  - (ii) *An additional test run shall be conducted at 5 m.p.h. above this speed.*
- (3) *When conducting stage-one and stage-two testing, if any of the monitored safety limits is exceeded on any segment of track intended for operation at track Class 6 speeds or greater, or on any segment of track intended for operation at more than 5 inches of cant deficiency, testing may continue provided that the track location(s) where any of the limits is exceeded be identified and test speeds be limited at the track location(s) until corrective action is taken. Corrective action may include making an adjustment in the track, in the vehicle, or both of these system components. Measurements taken on track segments intended for operations below track Class 6 speeds and at 5 inches of cant deficiency, or less, are not required to be reported.*
- (4) *Prior to the start of the qualification testing program, a qualifying TGMS specified in § 213.333 shall be operated over the intended route within 30 calendar days prior to the start of the qualification testing program.*

**Guidance:** Paragraph (f) contains the requirements for conducting qualification testing upon FRA approval of the test plan. This paragraph expressly requires that TGMS

equipment be operated over the intended test route within 30 days prior to the start of the testing, to help ensure the integrity of the test results. It also makes clear that exceptions to the safety limits that occur on track or at speeds that are not part of the test do not need to be reported. Specifically, any exception to the safety limits that occurs at speeds below track Class 6 speeds when the cant deficiency is at or below 5 inches does not need to be reported.

*345(g) Qualification testing results. The track owner or railroad shall submit a report to FRA detailing all the results of the qualification program. When simulations are required as part of vehicle qualification, this report shall include a comparison of simulation predictions to the actual wheel/rail force or acceleration data, or both, recorded during full-scale testing. The report shall be submitted at least 60 days prior to the intended operation of the equipment in revenue service over the route.*

**Guidance:** Paragraph (g) contains the requirements for reporting to FRA the results of the qualification testing program. When simulations are required as part of vehicle qualification, the submitted report shall include a comparison of simulation predictions to the actual wheel/rail force or acceleration data, or both, recorded during full-scale testing. Validation of computer simulation results as required in ((e)(6)) shall be included in this report, correlating with the qualification testing data. FRA has sponsored research to establish a set of procedures for validating models used in simulating vehicle/track dynamic interaction. The results are not conclusive. FRA is working on set up guidelines and procedures for validating models.

FRA encourages parties to approach FRA in the vehicle/track system qualification process should they have any questions or concerns about correlating simulation predictions with actual wheel/rail force or acceleration test data.

*345(h) Based on the test results and all other required submissions, FRA will approve a maximum train speed and value of cant deficiency for revenue service, normally within 45 days of receipt of all the required information. FRA may impose conditions necessary for safely operating at the maximum approved train speed and cant deficiency.*

**Guidance:** FRA approves a maximum train speed and value of cant deficiency for revenue service, based on the test results and all other required submissions. FRA intends to provide an approval decision normally within 45 days of receipt of all the required information. This paragraph emphasizes on “receipt of all the required information”. If the submission is incomplete upon preliminary examination, FRA will request for additional information. The 45 day period will start upon receipt of the additional information. This paragraph also makes clear that FRA may impose conditions necessary for safely operating at the maximum train speed and value of cant deficiency approved for revenue service.

*345(i) The documents required by this section must be provided to FRA by:*

- (1) The track owner; or*
- (2) A railroad that provides service with the same vehicle type over trackage of one or more track owner(s), with the written consent of each affected track owner.*

**Guidance:** This paragraph specifies that documents required by this section must be submitted to FRA by either the track owner or an operating entity that provides service with the vehicle type over trackage of one or more track owners with the written consent of all affected track owners. Paragraph (i)(2) states that if the vehicle owner is not the track

owner, a consent letter from each track owner must be included along with the qualification testing plan that is submitted in accordance with 213.345(e) before conducting any qualification testing. The written consent from the track owner must include an agreement to operate the vehicle type at the requested test conditions stated in the qualification testing plan. Only FRA has the authority to approve the vehicle type for testing purposes and subsequently for revenue service under this section.

**§ 213.347 Automotive or railroad crossings at grade**

*347(a) There shall be no at-grade (level) highway crossings, public or private, or rail-to-rail crossings at-grade on Class 8 and 9 track.*

*347(b) If train operation is projected at Class 7 speed for a track segment that will include rail-highway grade crossings, the track owner shall submit for FRA’s approval a complete description of the proposed warning/barrier system to address the protection of highway traffic and high-speed trains. Trains shall not operate at Class 7 speeds over any track segment having highway-rail grade crossings unless:*

- (1) An FRA-approved warning/barrier system exists on that track segment and;*
- (2) All elements of that warning/barrier system are functioning.*

**Guidance:** Highway/rail crossings, public or private, or rail-to-rail crossings at-grade are prohibited on Classes 8 and 9 track.

The railroad must submit for the approval of the FRA Associate Administrator for Railroad Safety/Chief Safety Officer a complete description of the proposed warning/barrier system to address the protection of highway traffic and high-speed trains before operation at Class 7 speeds is permitted at the crossings unless an FRA-approved warning/barrier system exists and all elements of that system are functioning.

Railroads are encouraged to install and maintain the optimal warning/barrier systems on crossings in Class 6 track.

**Defect Codes**

0347A	Highway/rail crossings or rail-to-rail crossings at-grade are present on Class 8 and 9 track.
0347B	Unapproved warning/barrier systems on class 7 track.

**§ 213.349 Rail-end mismatch**

*Any mismatch of rails at joints may not be more than that prescribed by the following table*

<b>Class of track</b>	<b>Any mismatch of rails at joints may not be more than the following</b>	
	<b>On the tread of the rail ends (inch)</b>	<b>On the gage side of the rail ends(inch)</b>
<i>Class 6, 7, 8, &amp; 9</i>	<i>1/8</i>	<i>1/8</i>

**Guidance:** Measure when bolts are tight. If bolts are not tight report the condition as a bolt defect. A deviation from the tolerance, as prescribed in the § 213.349 Table, constitutes a reportable exception.

Particular attention should be given to a mismatch on the gage side. A sharp flange, skewed truck, or combination of both may cause wheel climb at a gage mismatch, particularly on the outer rail of a curve. A mismatch, vertical or lateral, is extremely critical on high-speed railroads and may contribute to adverse dynamics in addition to traditional hazards.

**Defect Codes**

0349A1	Rail-end mismatch on tread of rail exceeds allowable.
0349A2	Rail-end mismatch on gage side of rail exceeds allowable.

**§ 213.351 Rail joints.**

*351(a) Each rail joint, insulated joint, and compromise joint shall be of a structurally sound design and dimensions for the rail on which it is applied.*

*351(b) If a joint bar is cracked, broken, or because of wear allows excessive vertical movement of either rail when all bolts are tight, it shall be replaced.*

*351(c) If a joint bar is cracked or broken between the middle two bolt holes it shall be replaced.*

*351(d) Each rail shall be bolted with at least two bolts at each joint.*

*351(e) Each joint bar shall be held in position by track bolts tightened to allow the joint bar to firmly support the abutting rail ends and to allow longitudinal movement of the rail in the joint to accommodate expansion and contraction due to temperature variations. When no-slip, joint-to-rail contact exists by design, the requirements of this section do not apply. Those locations, when over 400 feet long, are considered to be continuous welded rail track and shall meet all the requirements for continuous welded rail track prescribed in this subpart.*

*351(f) No rail shall have a bolt hole which is torch cut or burned.*

*351(g) No joint bar shall be reconfigured by torch cutting.*

**Guidance:** Rail joints are considered to be a necessary discontinuity and require special attention by railroad maintenance personnel and safety inspectors.

As far as possible, a rail joint should provide the same strength, stiffness, flexibility, and uniformity as the rail itself.

The TSS recognize these important aspects of rail joints and begin this section with a requirement that rail joints be of a structurally sound design and dimension for the rail on which they are applied (FRA and AREMA/AAR is to convene a working group which will issue guidelines on which joint bars meet the definition of “structurally sound” for the purpose of interchangeability with different rail sections).

For proper rail-load transfer to occur, rail joints must contact the head and base of rail when the bolts are tight. Many rail-joint designs have been used with varying degrees of success, and the TSS do not attempt to single out any particular design as the only acceptable joint. This would inhibit innovation in modern track design.

The TSS only requires structural soundness and bolt condition based on authorized operating train speed. Inspectors are reminded to be alert to locations where different rail sections are joined by rail joints not designed as compromise joints and not identified as fitting both rail sections. The following figure illustrates the proper application of compromise joint bars.

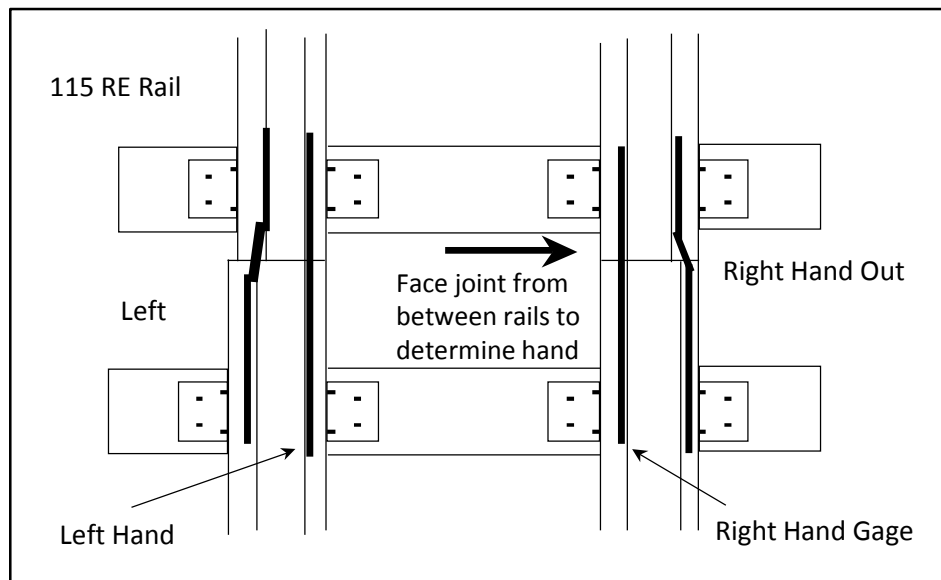

Failure of the owner to change out a center-cracked or other than center-cracked joint bar constitutes a reportable condition. Excessive vertical rail movement within a joint constitutes an exception to the TSS.

Track owners are required to maintain the prescribed number of bolts in rail joints.

Track bolts must be of sufficient tightness to allow the joint bars to support the joint firmly, but will not be so tight as to freeze the joint.

An inspector must be aware that a mechanical bolt tightener has the capability to torque the bolt beyond what is required, and thereby freeze the joint.

Paragraph (f) of this section prohibits the use of a rail containing a bolt hole that has been torch-cut or burned.

Paragraph (g) of this section prohibits the reconfiguration of joint bars by torch cutting.

Rail that has been welded together, either in the field or at a central facility, into lengths exceeding 400 feet are considered continuous welded rail for purposes of applying the requirements of this section.



**Defect Codes**

0351A	Rail joint not of structurally sound design and dimension.
0351B1	Cracked or broken joint bar (other than center-break).
0351B2	Worn joint bar allows vertical movement of rail in joint.
0351C	center cracked or broken joint bar.
0351D1	Less than 2 bolts per rail at each joint for conventional jointed rail.
0351D2	Less than 2 bolts per rail at any joint in continuous welded rail.
0351E	Loose joint bars.
0351F	Torch-cut or burned-bolt hole.
0351G	Joint bar reconfigured by torch cutting.

**§ 213.352 Torch cut rail**

*352(a) Except as a temporary repair in emergency situations no rail having a torch cut end shall be used. When a rail end with a torch cut is used in emergency situations, train speed over that rail shall not exceed the maximum allowable for Class 2 track. All torch cut rail ends in Class 6 shall be removed be within six months of September 21, 1998.*

*352(b) Following the expiration of the time limits specified in paragraph (a) of this section, any torch cut rail end not removed shall be removed within 30 days of discovery. Train speed over that rail shall not exceed the maximum allowable for Class 2 track until removed.*

**Guidance:** No torch cutting of rail is permitted except in an emergency such as when the track needs to be quickly returned to service following a derailment or washout.

No torch cut rails are considered to exist in Class 6 and above track prior to the effective date of this rule. Torch cut rails in Class 6, if they exist, must be removed before April 21, 1999. If found, the track speed over the torch cut rail must be reduced to Class 2 and the rail must be removed within 30 days of discovery.

**Defect Codes**

352A1	Torch cut rail applied for other than emergency.
352A2	Failure to remove torch cut rails within specified time frame.
352B1	Failure to remove non-inventoried torch cut rail within 30 days of discovery.
352B2	Train speed exceeds allowable over torch cut rail.

**§ 213.353 Turnouts, track crossings and lift rail assemblies or other transition devices on moveable bridges**

*353(a) In turnouts and track crossings, the fastenings must be intact and maintained so as to keep the components securely in place. Also, each switch, frog, and guard rail shall be kept free of obstructions that may interfere with the passage of wheels. Use of rigid rail crossings at grade is limited per § 213.347.*

**Guidance:** A turnout is a track arrangement consisting of a switch and frog with connecting and operating parts extending from the point of switch to the heel of frog that allows engines

and cars to pass from one track to another. Because of the operating or movable parts and lateral thrust, it is essential that fastenings be in place, tight, and in sound condition.

A crossing is a device used where two tracks intersect at grade permitting traffic on either track to cross the rails of the other. It may consist of four frogs, connected by short rails, or a plant-manufactured diamond. Because of the impact a crossing is subjected to, it is essential that fastenings be in place, tight, and in sound condition. Use of rigid rail crossings at grade is not permitted in Class 8 or 9 track.

Each switch, frog, and guard rail must be kept free of obstruction.

*353(b) Track shall be equipped with rail anchoring through and on each side of track crossings and turnouts, to restrain rail movement affecting the position of switch points and frogs. Elastic fasteners designed to restrict longitudinal rail movement are considered rail anchoring.*

**Guidance:** Anchors on each side of a turnout or crossing and through a turnout are mandatory on Class 6 and above. Elastic fasteners designed to restrict longitudinal rail movement are considered rail anchoring. Rail anchoring ensures the:

- Restraint of rail;
- Proper fit of the switch points; and
- Prevention of line irregularities.

Ties and timbers at switches and crossings must be of sound condition and well-tamped, and the roadbed must be adequately drained.

*353(c) Each flangeway at turnouts and track crossings shall be at least 1-1/2 inches wide.*

**Guidance:** Flangeways at turnouts and track crossings **must** be at least 1-1/2 inches wide.

*353(d) For all turnouts and crossovers, and lift rail assemblies or other transition devices on moveable bridges, the track owner shall prepare an inspection and maintenance Guidebook for use by railroad employees which shall be submitted to the Federal Railroad Administration. The Guidebook shall contain at a minimum –*

- (1) Inspection frequency and methodology including limiting measurement values for all components subject to wear or requiring adjustment.*
- (2) Maintenance techniques.*

**Guidance:** For all turnouts and crossovers, and lift rail assemblies or other transition devices on moveable bridges, the railroad must prepare an inspection and maintenance Guidebook for use by railroad employees which shall be submitted to FRA and which shall contain at a minimum:

- Inspection frequency and methodology, including limiting measurement values, for all components subject to wear or requiring adjustment.
- Maintenance techniques.

Inspectors must review the railroad's inspection Guidebook and conduct inspections based on the safety criteria contained therein. In addition, inspectors must ascertain if the Guidebook contains the required information listed above. Inspectors shall use judgment when citing the railroad for its failure to adhere to its Guidebook.

The Guidebook must contain provisions addressing traditional types of high-speed turnouts along with those components which may be developed in the future. Therefore, the inspector has available those defect codes that have been used for several years on lower speed turnouts and switches.

Turnouts must be walked and measurements made before they can be included on the Inspection Report as a unit inspected.

The inspector must do the following when inspecting switches:

- Confirm compliance with railroad Guidebook.
- Check alignment, gage, and surface.
- Examine condition as to wear of switch points and stock rails.
- See that all bolts, nuts, cotter pins, and other fastenings are in place, in good condition, and are properly tightened.
- See that switch points fit snugly against the rail when the switch is thrown in either position.
- Test, in the presence of the owner's representative, the operation of switches for lost motion and loose connections.
- Examine, if applicable, the rod and fastenings that connect the switch point to the switch circuit controller to ensure they are in place and in good condition.
- Examine the condition and support of spring and power switch machines and hand-thrown switch stands, including automatic or safety switch stands. Stand and machine fastenings to the head block ties must be tight to avoid any movement or play.
- Examine switch-lock, keeper (latch), and foot-lock apparatus.
- Examine condition of switch position indicator and note any unnecessary obstruction to its visibility.
- Examine the heel block, its fastenings, and bars; or, in the absence of a heel block, examine the heel of the switch point.
- Examine the seating of stock rails in the switch plates to ensure that the outer tread of a wheel cannot engage the gage side of these rails and that chairs or braces do not cant these rails in.
- Examine the insulation in the gage plates and switch rods in signal territory.

When inspecting frogs, inspectors should do the following:

- Confirm compliance with railroad Guidebook.
- Determine if frogs may be classified as bolted rigid, solid manganese, moveable, rail-bound manganese, or spring rail.
- Ensure that a frog is supported throughout on sound ties and is well-tamped.
- Closely examine every spring rail frog encountered during an inspection. While spring rail frogs have been successfully used for many years, their unique design requires special maintenance attention to avoid derailment hazards to trailing-point train movements on the main track.
- Examine the toe of each spring rail frog. It must be solidly supported and proper hold-down housing clearance maintained to avoid excessive vertical movement of the wing rail. The first sign that this is occurring will be gouging on the gage corner of the wing rail behind the point of frog. Wheel gouging must not be confused with channeling in the spring wing rail that is machined, at the time of manufacture, to accommodate wheel tread transition.

- Determine if the toe is solidly tamped. If it is not, and excessive horn and housing clearance exists, the wing rail may have vertical motion operating on the point rail in a trailing-point movement and the forces on the wing rail will cause the wing rail to move laterally, allowing the wheel to drop in at the throat of the frog.

*353(e) Each hand operated switch shall be equipped with a redundant operating mechanism for maintaining the security of switch point position.*

#### **Defect Codes**

0353A1	Loose, worn, or missing switch clips.
0353A2	Loose, worn, or missing clip bolts (transit, side jaw, eccentric, vertical).
0353A3	Loose, worn, or defective connecting rod.
0353A4	Loose, worn, or defective connecting rod fastening.
0353A5	Loose, worn, or defective switch rod.
0353A6	Loose, worn, or missing switch rod bolts.
0353A7	Worn or missing cotter pins.
0353A8	Loose or missing rigid rail braces.
0353A9	Loose or missing adjustable rail braces.
0353A10	Missing switch, frog, or guard rail plates.
0353A11	Loose or missing switch point stops.
0353A12	Loose, worn, or missing frog bolts.
0353A13	Loose, worn, or missing guard rail bolts.
0353A14	Loose, worn or missing guard rail clamps, wedge, separator block, end block, or other component.
0353A15	Obstruction between switch point and stock rail.
0353A16	Obstruction in flangeway of frog.
0353A17	Obstruction in flangeway of guard rail.
0353A18	Insufficient anchorage to restrain rail movement.
0353A19	Stock rail not securely seated in switch plates.
0353A20	Stock rail canted by overtightening rail braces.
0353A21	Improper fit between switch point and stock rail.
0353A22	Outer edge of wheel contacting gage side of stock rail.
0353A23	Excessive lateral or vertical movement of switch point.
0353A24	Heel of switch insecure.
0353A25	Insecure switch stand or switch machine.
0353A26	Insecure connecting rod.
0353A27	Throw lever operable with switch lock or keeper in place.
0353A28	Switch position indicator not clearly visible.
0353A29	Unusually chipped or worn switch point.
0353A30	Improper switch closure due to metal flow.
0353A31	Insufficient flangeway depth.
0353A32	Frog point chipped, broken, or worn in excess of allowable.
0353A33	Tread portion of frog worn in excess of allowable.
0353A34	Outer edge of wheel contacting side of spring wing rail.
0353A35	Toe of wing rail not fully bolted and tight.
0353A36	Ties under or wing rail not solidly tamped.
0353A37	Bolt-hole defect in frog.
0353A38	Head and web separation in frog.
0353A39	Insufficient tension in spring to hold wing rail against point rail.

0353A40	Excessive clearance between hold-down housing and horn.
0353B	Insufficient rail anchors through or on each side of crossing or turnout.
0353Di	Turnout or crossover not being maintained in accordance with guidebook.
0353Dii	Lift rail assembly or other transition device on moveable bridge not being maintained in accordance with guidebook.
0353E	Hand operated switch not equipped with a redundant operating mechanism for maintaining the security of switch point position

**§ 213.355 Frog guard rails and guard faces; gage**

The guard check and guard face gages in frogs shall be within the limits prescribed in the following table --

<i>Class of track</i>	<i><u>Guard check gage</u> The distance between the gage line of a frog to the guard line<sup>1</sup> of its guard rail or guarding face, measured across the track at right angles to the gage line<sup>2</sup>, may not be less than</i>	<i><u>Guard face gage</u> The distance between guard lines<sup>1</sup>, measured across the track at right angles to the gage line<sup>2</sup>, may not be more than</i>
<i>Class 6, 7, 8 and 9 track</i>	<i>4' 6-1/2"</i>	<i>4' 5"</i>

<sup>1</sup> A line along that side of the flangeway which is nearer to the center of the track and at the same elevation as the gage line.

<sup>2</sup> A line five-eighths of an inch below the top of the center line of the head of the running rail, or corresponding location of the tread portion of the track structure.

**Guidance:** In some high-speed turnout designs, guard rails are not installed.

A guard rail is laid parallel to the running rail opposite to a frog to form a flangeway with the rail and thereby to hold wheels of equipment to the proper alignment when passing through the frog.

A guard rail must be maintained in the proper relative position to the frog in order to accomplish its important intended safety function. Inspectors should examine guard rails carefully to see that they are adequately fastened, and when measuring guard rail gage, fully consider any movement of guard rail or frog under traffic conditions.

Section 213.355 clearly specifies allowable tolerances for guard check and guard face gage for Classes 6 through 9 track.

**Defect Codes**

0355A1	Guard check gage less than allowable.
0355A2	Guard face gage exceeds allowable.
0355A3	Cracked or broken guard rail.

**§ 213.357 Derails**

*357(a) Each track, other than a main track, which connects with a Class 7, 8 or 9 main track shall be equipped with a functioning derail of the correct size and type, unless railroad equipment on the track, because of grade characteristics cannot move to foul the main track.*

*357(b) For the purposes of this section, a derail is a device which will physically stop or divert movement of railroad rolling stock or other railroad on-track equipment past the location of the device.*

*357(c) Each derail shall be clearly visible. When in a locked position, a derail shall be free of any lost motion which would prevent it from performing its intended function.*

*357(d) Each derail shall be maintained to function as intended.*

*357(e) Each derail shall be properly installed for the rail to which it is applied.*

*357(f) If a track protected by a derail is occupied by standing railroad rolling stock, the derail shall be in derailing position.*

*357(g) Each derail on a track which is connected to a Class 7, 8 or 9 main track shall be interconnected with the signal system.*

**Guidance:** Each track, other than a main track, which connects with a Class 7 and above main track must be equipped with a functioning derail of the correct size and type. For purposes of this section, main track is a track, other than an auxiliary track, extending through yards and between stations, upon which trains are operated by timetable or train orders, or both, or the use of which is governed by block signals. Thus, a controlled siding is considered a main track.

For purposes of § 213.357, a derail is a device which will physically stop or divert movement of railroad rolling stock or other railroad on-track equipment past the location of the device.

Inspectors must use judgment in evaluating whether or not a particular situation should constitute an exception to the requirement for derails. If there is any doubt that the railroad equipment, “because of grade characteristics, cannot move to foul the main track,” the inspector should promptly contact the regional track specialist for guidance. The inspector should note that § 213.361 requires the railroad to submit a “right-of-way plan” for FRA approval. This plan must contain provisions for the intrusion of vehicles from adjacent tracks. Inspectors must be constantly vigilant to identify circumstance where intrusion protection is needed.

Derails are of various designs and may be of the following types: switch point, spring switch point, sliding, hinged, and portable.

Derails can be operated by various means: electrical, hand throw, lever, and mechanical rod from a point other than at the derail. They must be installed to derail rolling stock in a direction away from the track or facility to be protected.

If track protected by a derail is occupied by standing railroad rolling stock, the derail must be in derailing position. Of course, the derail would have to be placed in a non-derailing position to prepare for an intentional train movement.

It is absolutely critical that derails on track connected to Class 7 and above main track shall be interconnected with a signal system. Inspectors shall periodically make joint inspection with Signal and Train Control inspectors to determine compliance with this requirement.

**Defect Codes**

0357A1	Derail not present when required.
0357A2	Improper size derail.
0357B	Derailing device not of proper design physically stop or divert movement.
0357C1	Derail not clearly visible.
0357C2	Derail operable when locked.
0357D	Loose, worn, or defective parts of derail.
0357E	Improperly installed derail.
0357G	Derail not interconnected to the signal system when required.

**§ 213.359 Track stiffness**

*359(a) Track shall have a sufficient vertical strength to withstand the maximum vehicle loads generated at maximum permissible train speeds, cant deficiencies and surface defects. For purposes of this section, vertical track strength is defined as the track capacity to constrain vertical deformations so that the track shall return following maximum load to a configuration in compliance with the vehicle/track interaction safety limits and geometry requirements of this subpart.*

*359(b) Track shall have sufficient lateral strength to withstand the maximum thermal and vehicle loads generated at maximum permissible train speeds, cant deficiencies and lateral alignment defects. For purposes of this section lateral track strength is defined as the track capacity to constrain lateral deformations so that track shall return following maximum load to a configuration in compliance with the vehicle/track interaction safety limits and geometry requirements of this subpart.*

**Guidance:** Compliance with this section is demonstrated by compliance with track geometry, vehicle/track interaction and CWR requirements in this subpart. Since direct measurements of vertical and lateral track strength are currently difficult to obtain, inspectors must monitor track strength using the tools contained in the track geometry, automated inspection and CWR sections.

Track must have sufficient vertical strength and lateral strength to withstand the maximum loads generated at maximum permissible train speeds, cant deficiency and lateral or vertical defects so that the track will return to a configuration in compliance with the track performance and geometry requirements of this subpart.

It is imperative that the track structure is structurally qualified to accept the loads without unacceptable deformation. The limit of 0.5 for the Net Axle L/V Ratio in the table of

vehicle/track interaction safety limits in § 213.333 is based on an extrapolation of the Prud'homme limit and experimental data.

Lateral loads generated by vehicles operating under maximum speed, cant deficiency, thermal loads, and initial line defect conditions should not cause the exception of an allowable deflection limit. Key influencing parameters are the track lateral resistance characteristics, tie/ballast friction coefficients, vehicle vertical axle loads, track curvature, thermal loads, and constant versus variable lateral axle loads.

NO DEFECT CODES

**§ 213.361 Right-of-Way**

*The track owner in Class 8 and 9 shall submit a barrier plan, termed a “right-of-way plan,” to the Federal Railroad Administration for approval. At a minimum, the plan will contain provisions in areas of demonstrated need for the prevention of --*

*361(a) Vandalism;*

*361(b) Launching of objects from overhead bridges or structures into the path of trains; and*

*361(c) Intrusion of vehicles from adjacent rights-of-way.*

**Guidance:** The railroad is required to submit a barrier plan to the FRA Associate Administrator for Railroad Safety/Chief Safety Officer for approval. The plan shall address vandalism, launching of objects from overhead bridges or structures, and intrusion.

Inspectors must obtain a copy of the railroad’s “right-of-way” plan either from the railroad or the regional track specialist. Inspectors will be asked to evaluate the railroad’s right-of-way plan for comprehensiveness and may be directed to prepare a memorandum of recommendations concerning the plan. After the plan becomes effective, inspectors must monitor the safety of the high-speed railroad and advise the regional track specialist of any concerns.

**Defect Codes**

0361Ai	Failure to provide “Right-of-way” plan.
0361Aii	Failure of “Right-of-way” plan to contain required information.

**§ 213.365 Visual inspections**

*365(a) All track shall be visually inspected in accordance with the schedule prescribed in paragraph (c) of this section by a person designated under § 213.305.*

*365(b) Each inspection shall be made on foot or by riding over the track in a vehicle at a speed that allows the person making the inspection to visually inspect the track structure for compliance with this part. However, mechanical, electrical, and other track inspection devices may be used to supplement visual inspection. If a vehicle is used for visual inspection, the speed of the vehicle may not be more than 5 mph when passing over track crossings and turnouts, otherwise, the inspection vehicle speed shall be at the sole discretion of the inspector,*



*based on track conditions and inspection requirements. When riding over the track in a vehicle, the inspection will be subject to the following conditions --*

- (1) *One inspector in a vehicle may inspect up to two tracks at one time provided that the inspector's visibility remains unobstructed by any cause and that the second track is not centered more than 30 feet from the track upon which the inspector is riding;*
- (2) *Two inspectors in one vehicle may inspect up to four tracks at a time provided that the inspector's visibility remains unobstructed by any cause and that each track being inspected is centered within 39 feet from the track upon which the inspectors are riding;*
- (3) *Each main track is actually traversed by the vehicle or inspected on foot at least once every two weeks, and each siding is actually traversed by the vehicle or inspected on foot at least once every month. On high density commuter railroad lines where track time does not permit an on track vehicle inspection, and where track centers are 15-foot or less, the requirements of this paragraph (b)(3) will not apply; and*
- (4) *Track inspection records shall indicate which track(s) are traversed by the vehicle or inspected on foot as outlined in paragraph (b)(3) of this section.*

*365(c) Each track inspection shall be made in accordance with the following schedule --*

<b>Class of track</b>	<b>Required frequency</b>
6, 7, & 8	<i>Twice weekly with at least 2 calendar-day's interval between inspections.</i>
9	<i>Three times per week.</i>

*365(d) If the person making the inspection finds a deviation from the requirements of this part, the person shall immediately initiate remedial action.*

*365(e) Each switch, turnout, crossover, and lift rail assemblies on moveable bridges shall be inspected on foot at least weekly. The inspection shall be accomplished in accordance with the Guidebook required under § 213.353.*

*365(f) In track classes 8 and 9, if no train traffic operates for a period of eight hours, a train shall be operated at a speed not to exceed 100 mph over the track before the resumption of operations at the maximum authorized speed.*

**Guidance:** The success of the track safety program depends on the adequacy of the railroad's inspection and compliance program.

To assure that railroads are providing proper inspection coverage, Federal and State inspectors must periodically examine the railroad's inspection records.

As specified in this section of the TSS, the owner must see that all track is inspected in accordance with the prescribed schedule. Failure of the owner to comply with this schedule may constitute a violation.

If an owner's designated inspector or supervisor finds a deviation from the TSS, failure to initiate remedial action immediately may constitute a violation.

The FRA or State inspector will not make the owner's prescribed inspections, but will monitor them for adherence to the TSS.

For purposes of this section, “main track” is defined as a track, other than an auxiliary track, extending through yards and between stations.

Paragraph (b) does not require five mph over highway crossings. However, this section still requires an operator to perform an adequate inspection regardless of the need to permit safe operation of inspection vehicles through highway crossings.

Paragraph (b) contains language specifying the number of additional tracks that can be inspected, depending on whether one or two qualified individuals are in the vehicle, and depending on the distance between adjacent tracks measured between track center lines. Inspectors may inspect multiple tracks from hi-rail vehicles only if their view of the tracks inspected is unobstructed by tunnels, differences in ground level, or any other circumstance that would prevent an unobstructed inspection of all the tracks they are inspecting.

This section also requires railroad to traverse each main track bi-weekly and each siding monthly, and to so note on the appropriate track inspection records.

It is recognized that many high-speed turnouts (and lift assemblies on moveable bridges) and those which will probably be designed in the future may have unique properties. The railroad must thoroughly understand the nature of these turnouts and establish maintenance and inspection procedures which shall be monitored by FRA and State inspectors. Each turnout, crossover, and lift rail assembly on moveable bridges shall be inspected at least weekly and accomplished in accordance with the Guidebook required under § 213.353. Federal and State inspectors must be familiar with the Guidebook and conduct inspections to monitor the railroad’s compliance with the safety limits and procedures established in the Guidebook. The Guidebook must also include provisions for the inspection and maintenance of traditional turnouts. The high-speed railroad must inspect the condition of frogs, stock rails, switch points, etc. as the railroad would do in the lower track classes. (See the discussion in § 213.353.)

In track classes 8 and 9, if traffic is not operated for a period of eight hours, the railroad is required to operate a train not to exceed 100 mph before the resumption of operations at the maximum authorized speed. This provision addresses the possibility of objects or debris being placed on the track. It also mitigates the potential occurrences of vandalism.

This section requires that each inspection performed in accordance with the schedule must be made on foot or by riding over the track in a vehicle at a speed that allows the person making the inspections to visually inspect the track structure for compliance. Therefore, an inspection made from a vehicle driven alongside the track does not constitute an inspection performed at the required frequency. The railroad may make additional inspections using other inspection methods provided that these inspections are Reserved to comply with frequency requirements.

Inspecting after dark is in compliance with the requirements of this Subpart, as long as the railroad inspector is capable of detecting defects. As an example, inspections are routinely made in tunnels or subways with limited or no lighting, and maintenance requirements may require inspections after daylight hours. Appropriate artificial lighting often can be substituted.

When FRA and State inspectors are conducting inspections on a hi-rail vehicle, only the track occupied will be inspected and recorded on the F 6180.96 form. When conducting a walking inspection, multiple tracks may be inspected and counted as units on the F 6180.96 form. It is recognized that walking inspections reveal more defective conditions than hi-rail inspections. Therefore FRA and State inspectors may include multiple tracks while conducting walking inspections. Inspectors will use good judgment in ensuring a high quality inspection while conducting walking inspections. In order to insure that FRA inspections are high quality, when making hi-rail inspections, FRA inspectors will only inspect the track they occupy.

### Defect Codes

0365A	Track inspected by other than qualified designated individual.
0365B	Track being inspected at excessive speed.
0365B1	One inspector inspecting more than two tracks.
0365B2	Two inspectors inspecting more than four tracks.
0365B3i	Main track not traversed within the required frequency.
0365B3ii	Siding track not traversed within the required frequency.
0365Bi	Inspection performed on track outside of maximum allowable track center distances.
0365C	Failure to inspect at required frequency.
0365D	Failure to initiate remedial action for deviations found.
0365E1	Failure to inspect turnouts at required frequency.
0365E2	Failure to inspect track crossings at required frequency.
0365E3	Failure to inspect lift rail assemblies or other transition devices on moveable bridges at required frequency.
0365F	Failure to operate a train at 100 mph or less after an eight hour period with no train operation.

### § 213.367 Special inspections

*In the event of fire, flood, severe storm, temperature extremes or other occurrence which might have damaged track structure, a special inspection shall be made of the track involved as soon as possible after the occurrence and, if possible, before the operation of any train over that track.*

**Guidance:** This section is necessarily general in nature because it is not practical to specify all the conditions that could trigger a special inspection, nor the manner and timing which any particular special inspection should be conducted. This section is not meant to imply that train operations must necessarily stop until the special inspection is made. However, all special inspections should be conducted for the primary purpose of determining whether the track structure is safe for the continued operation of trains. Inspectors are directed to review the significant impacts to railroad operations in regard to storms as discussed in any applicable safety advisory.

Because a number of train derailments have been caused by unexpected track damage from moving water in the past, FRA deemed it appropriate to issue a safety advisory recommending procedures that reflect best industry practice for special track inspections. The procedures consist of: (1) prompt notification of dispatchers of expected bad weather;

(2) limits on train speed on all track subject to flood damage, following the issuance of a flash flood warning, until special inspection can be performed; (3) identification of bridges carrying Class 4 or higher track which are vulnerable to flooding and over which passenger trains operate; (4) availability of information about each bridge, such as identifying marks, for those who may be called to perform a special inspection; (5) training programs and refresher training for those who perform special inspections; and (6) availability of a bridge maintenance or engineering employee to assist the track inspectors in interpreting the inspectors' findings.

Although the advisory contains a sample list of surprise events that routinely occur in nature, this provision is not limited to only the occurrences listed or to only natural disasters. Section 213.367 addresses the need to inspect after "other occurrences" which include such natural phenomena as temperature extremes, as well as unexpected events that are human-made, e.g., a vehicle that falls on the tracks from an overhead bridge, a water main-break that floods a track roadbed, or terrorist activity that damages track. This interpretation is not new; FRA has always viewed this section to encompass sudden "surprise" events of all kinds that affect the safety and integrity of track.

Inspectors should determine the procedures that have been established by the railroad to comply with § 213.367, mindful that advisory procedures are not mandatory. Procedures should include the method employed by the railroad to receive information on severe weather, i.e., who receives the information and what is done with that information. When the railroad is notified of a track-damaging occurrence, a special inspection must be made. A track owner may designate any official to be responsible to make a determination on whether a special inspection, under § 213.367, is required. The designation is not limited to any certain craft, but the official must be trained and qualified to assure a proper inspection is conducted.

**Defect Codes**

0367A	Failure to conduct special inspections when required.
-------	---

**§ 213.369 Inspection records**

*369(a) Each owner of track to which this part applies shall keep a record of each inspection required to be performed on that track under this subpart.*

*369(b) Except as provided in paragraph (e) of this section, each record of an inspection under § 213.365 shall be prepared on the day the inspection is made and signed by the person making the inspection. Records shall specify the track inspected, date of inspection, location and nature of any deviation from the requirements of this part, and the remedial action taken by the person making the inspection. The owner shall designate the location(s) where each original record shall be maintained for at least one year after the inspection covered by the record. The owner shall also designate one location, within 100 miles of each State in which they conduct operations, where copies of record which apply to those operations are either maintained or can be viewed following 10 days notice by the Federal Railroad Administration.*

**Guidance:** Track owners are required to keep a record of each inspection according to the requirements of this subpart, prepared on the day of inspection and signed by the person making the inspection.

The regulation allows railroads to designate a location within 100 miles of each State (designated locations) where records can be viewed by inspectors. Inspectors are required to give 10 days advance notice before conducting the record keeping inspection of designated locations. The regulation does not require the railroads to maintain the records at these designated locations, only to be able to provide viewing of them at the locations within 10 days after notification. The TSS stipulates locations within 100 miles of each State, rather than locations in each State, to accommodate those railroads whose operations may cross a State's line by only a few miles. In those cases, the railroad could designate a location in a neighboring State, provided the location is within 100 miles of that State's border. Records must be kept for at least 1 year after the inspection covered by the report. It is appropriate for the inspector to expect all records will be available for inspection up to the date of notification

*369(c) Rail inspection records shall specify the date of inspection, the location and nature of any internal defects found, the remedial action taken and the date thereof, and the location of any intervals of track not tested per § 213.339(d). The owner shall retain a rail inspection record for at least two years after the inspection and for one year after remedial action is taken.*

**Guidance:** Paragraph (c) requires a track owner to record any locations where a proper rail inspection cannot be performed because of rail surface conditions. Paragraph § 213.339(d) specifies that if rail surface conditions prohibit the railroad from conducting a proper search for rail defects, a test of that rail does not fulfill the requirements of 213.339(a) which requires a search for internal defects at specific intervals. This paragraph requires a record keeping of those instances.

*369(d) Each owner required to keep inspection records under this section shall make those records available for inspection and copying by the Federal Railroad Administrator.*

*369(e) For purposes of compliance with the requirements of this section, an owner of track may maintain and transfer records through electronic transmission, storage, and retrieval provided that --*

- (1) The electronic system be designed such that the integrity of each record maintained through appropriate levels of security such as recognition of an electronic signature, or other means, which uniquely identify the initiating person as the author of that record. No two persons shall have the same electronic identity;*
- (2) The electronic storage of each record shall be initiated by the person making the inspection within 24 hours following the completion of that inspection;*
- (3) The electronic system shall ensure that each record cannot be modified in any way, or replaced, once the record is transmitted and stored;*
- (4) Any amendment to a record shall be electronically stored apart from the record which it amends. Each amendment to a record shall be uniquely identified as to the person making the amendment;*
- (5) The electronic system shall provide for the maintenance of inspection records as originally submitted without corruption or loss of data; and*

- (6) *Paper copies of electronic records and amendments to those records, that may be necessary to document compliance with this part, shall be made available for inspection and copying by the FRA and track inspectors responsible under § 213.305. Such paper copies shall be made available to the track inspectors and at the locations specified in paragraph (b) of this section.*
- (7) *Track inspection records shall be kept available to persons who performed the inspection and to persons performing subsequent inspections.*

**Guidance:** Paragraph (e) contains requirements for maintaining and retrieving electronic records of track inspections. This allows each railroad to design its own electronic system as long as the system meets the specified criteria to safeguard the integrity and authenticity of each record. The provision also requires that railroads make available paper copies of electronic records, when needed, by FRA or by railroad track inspectors.

The track owner has the liberty to devise any form deemed sufficient to meet the required standards. If the owner requires inspections at more frequent intervals than specified by § 213.365(c), then the only requirement is to prepare and maintain an inspection record to conform with the minimum inspection frequency. This paragraph is explicit concerning the required information contained in the inspection records. They must specify the track inspected [including the provisions under § 213.365(b)(3)], date of inspection, location and nature of any defect, and the remedial action taken by the person making the inspection. If train operations were conducted over the defect, the nature of the defect would require a measurement to include the specific parameters or limits. When defects are discovered, the track owner's inspectors must determine the risk imposed and immediately initiate remedial action, in accordance with § 213.303. If a speed restriction is used as remedial action, the reduced speed should be shown in the inspection records.

Railroad track inspectors are required to list all deviations from the TSS on their inspection record. FRA and State inspectors should review a railroad inspection record to determine if the reported data accurately indicates the track conditions as they exist in the field. Railroad inspectors are not limited to recording deviations from the TSS (e.g., railroad maintenance items). Inspectors should compare the defects they find with the railroad inspectors reports to determine the level of compliance with the railroad's inspection program. If multiple tracks are being inspected, the records must designate the track traversed, and any tracks not inspected due to visibility obstruction or excessive distance as required under § 213.365.

When two qualified persons inspect multiple tracks in accordance with § 213.365(b), one report or two reports may be optionally prepared. If one report is used, the report must include a notation such as signature, initials or printed name of the second inspector.

Rail inspection records must be maintained by the track owner for at least 2 years after the inspection and for one year after remedial action is taken. The record must specify the location and nature of any rail defects found through internal inspection and the remedial action taken and the date thereof. This record may consist of log sheets combined with a standard rail defect and change-out report, computer records, or other data kept by the track owner and containing all the required information.

The rail inspection records must specify the locations of any rail that, due to rail surface conditions, prohibit the railroad from conducting a valid search for internal defects at the required frequency. If a valid search cannot be conducted before the time or tonnage frequency expires, the remedial action and date of remedial action must be recorded on the inspection records.

*369(f) Each vehicle/track interaction safety record required under § 213.333 (g), and (m) shall be made available for inspection and copying by FRA at the locations specified in paragraph (b) of this section.*

**Guidance:** Inspection records must be made available to the FRA or State inspector for inspection and copying. A track owner may elect to maintain and transfer records through electronic transmission, storage, and retrieval procedures. Each record must have sufficient security to maintain the integrity of the record. Levels of security must identify the person making the inspection as the author of the record. No two individuals will have or share the same electronic signature or identity. If individuals use an electronic signature or identity other than their own, violations or personal liability action should be considered for all parties involved. The integrity of electronic inspection record systems is an extremely sensitive issue. Should the system integrity be compromised, an inspector will contact the appropriate track specialist immediately. Should the track specialist be unavailable the inspector will notify the appropriate Regional Administrator. Headquarters Track Division will also be notified.

The system must assure that no record can be replaced, deleted, or modified in any way, once the record has been transmitted and stored. Each amendment to a record shall be stored separately from the record it amends. Each amendment must identify the person making the amendment and have sufficient security to maintain the integrity of the amendment.

For electronic records, inspection records must be completed the day of the inspection either on computer or temporarily on paper. The electronic record must then be uploaded to the permanent electronic storage system where the record will be maintained for 1 year. The uploading of each inspection record must be completed within 24 hours following the completion of the inspection.

An advantage of an electronic system is the associated reduction in paperwork. Inspectors, therefore, must rely on viewing the record on the terminal or monitor screen whenever it is made available for viewing by the railroad. Although printouts of records must be made available to Federal and State inspectors, inspectors are discouraged from requesting paper copies of electronic records unless necessary to document noncompliance. A paper copy of an electronic record may be marked “original” and included in the documentation necessary for a violation report when recommending civil penalties.

Paper copies of electronic records and amendments will be made available for inspection and copying to the FRA or State inspector. These records will be furnished upon request at the location specified by the railroad as required in paragraph (b) of this section. A paper copy of any electronic inspection record or amendment will be made available to the railroad inspector or any subsequent railroad inspectors performing inspections of the same territory upon request.

**Defect Codes**

0369A	Failure to keep records as required.
0369B1	Failure of inspector to complete report at time of inspection.
0369B2	Failure of inspector to sign report.
0369B3	Failure of inspector to provide required information.
0369C	Failure of rail inspection record to provide required information.
0369D	Failure to make records available for copying and inspection.
0369E1	Electronic system does not maintain the integrity of each record.
0369E2	Electronic storage not initiated within 24 hours.
0369E3	Electronic system allows record or amendments to be modified.
0369E4I	Electronic amendments not stored separately from record.
0369E4II	Person making electronic amendment not identified.
0369E5	Electronic system corrupts or losses data.
0369E6	Paper copies of records not made available for inspection and copying.
0369E7	Inspection reports not available to inspector or subsequent inspectors.



**Appendix D to Part 213—Minimally Compliant Analytical Track (MCAT) Simulations Used for Qualifying Vehicles to Operate at High Speeds and at High Cant Deficiencies**

1. This appendix contains requirements for using computer simulations to comply with the vehicle/track system qualification testing requirements specified in subpart G of this part. These simulations shall be performed using a track model containing defined geometry perturbations at the limits that are permitted for a specific class of track and level of cant deficiency. This track model is known as MCAT, Minimally Compliant Analytical Track. These simulations shall be used to identify vehicle dynamic performance issues prior to service or, as appropriate, a change in service, and demonstrate that a vehicle type is suitable for operation on the track over which it is intended to operate.

2. As specified in § 213.345(c)(2), MCAT shall be used for the qualification of new vehicle types intended to operate at track Class 7 speeds or above, or at any curving speed producing more than 6 inches of cant deficiency. MCAT may also be used for the qualification of new vehicle types intended to operate at speeds corresponding to Class 6 track, as specified in § 213.345(c)(1). In addition, as specified in § 213.345(d)(1), MCAT may be used to qualify on new routes vehicle types that have previously been qualified on other routes and are intended to operate at any curving speed producing more than 6 inches of cant deficiency, or at curving speeds that both correspond to track Class 7 speeds or above and produce more than 5 inches of cant deficiency.

**General Guidance:** Appendix D is a new appendix containing the requirements for the use of computer simulations to demonstrate compliance with the vehicle/track system qualification testing requirements specified in subpart G of this part. Comprehensive computational models are capable of assessing the response of vehicle designs to a wide range of track conditions corresponding to the limiting conditions allowed for each class of track. Portions of the qualification requirements in subpart G can be met by simulating vehicle testing using a suitably-validated vehicle model instead of testing an actual vehicle over a representative track segment.

As explained in paragraph 1, the simulations described in this appendix are required to be performed using a track model containing defined geometry deviations for different track segments at the limits that are permitted for a specific class of track and level of cant deficiency. This track model is referred to as MCAT. These simulations shall be used to identify vehicle dynamic performance issues prior to service or, as appropriate, a change in service, and demonstrate that a vehicle type is suitable for operation on the track to be used. The lengths of the MCAT segments identified in this appendix are the same as the segment lengths that were used in the modeling of several representative high-speed vehicles. (for additional information, see the discussion of research and computer modeling in the Technical Background section of the *Federal Register*.)

In order to validate a computer model, the predicted results must be compared to actual data from on-track, instrumented vehicle performance testing using accelerometers, or other instrumentation, or both. Validation must also demonstrate that the model is sufficiently robust to capture fundamental responses observed during field testing. Once validated, the computer model can be used for MCAD or assessing a range of operating conditions or even to examine modifications to current designs.

Paragraph 2 concerns the application of MCAT for vehicle/track system qualification in § 213.345 and was developed in accordance with the changes made to § 213.345.

- (a) **Validation.** *To validate the vehicle model used for simulations under this part, the track owner or railroad shall obtain vehicle simulation predictions using measured track geometry data, chosen from the same track section over which testing shall be performed as specified in § 213.345(c)(2)(ii). These predictions shall be submitted to FRA in support of the request for approval of the qualification testing plan. Full validation of the vehicle model used for simulations under this part shall be determined when the results of the simulations demonstrate that they replicate all key responses observed during qualification testing.*

**Guidance:** Paragraph (a) addresses the validation of the vehicle model used for simulations. As discussed in § 213.345(g), FRA has sponsored research to establish a set of procedures for validating models used in simulating vehicle/track dynamic interaction. FRA has published this research. The results are not conclusive. FRA is working to set up procedures and, when complete, make it part of FRA's formal guidance on compliance with the Track Safety Standards. Again, in the interim, FRA encourages parties to approach FRA early in the qualification process should they have any questions or concerns about correlating simulation predictions with measured track geometry data.

- (b) **MCAT layout.** *MCAT consists of nine segments, each designed to test a vehicle's performance in response to a specific type of track perturbation. The basic layout of MCAT is shown in figure 1 of this appendix, by type of track (curving or tangent), class of track, and cant deficiency (CD). The values for wavelength,  $\lambda$ , amplitude of perturbation,  $a$ , and segment length,  $d$ , are specified in this appendix. The bars at the top of figure 1 show which segments are required depending on the speed and degree of curvature. For example, the hunting perturbation section is not required for simulation of curves greater than or equal to 1 degree.*

**Guidance:** Paragraph (b) specifies the layout of the MCAT segments. The MCAT layout in Figure 1 below clarifies which segments are required depending on the speed and the degree of curvature involved. In particular, the hunting perturbation segment is not required for simulations of curves greater than or equal to 1 degree; the short warp segment is not required for tangent track simulations; and the combined perturbation segment is required on tangent track only for Class 9 track, and is not required for simulations of no more than 5 inches of cant deficiency other than for Class 9 track, where it is required for all cant deficiency values.

**Figure 1 of Appendix D to Part 213**  
**Basic MCAT Layout**

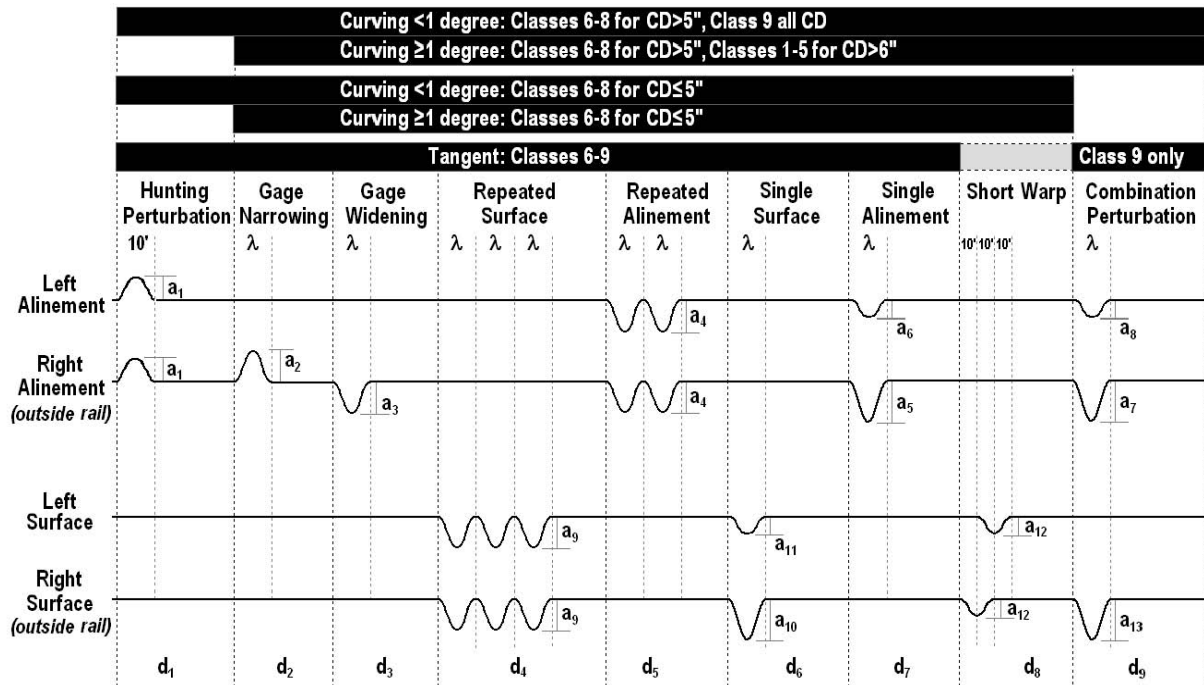

(1) MCAT segments. MCAT's nine segments contain different types of track deviations in which the shape of each deviation is a versine having wavelength and amplitude varied for each simulation speed as further specified. The nine MCAT segments are defined as follows:

- (i) Hunting perturbation ( $a_1$ ): This segment contains an alinement deviation having a wavelength,  $\lambda$ , of 10 feet and amplitude of 0.25 inch on both rails to test vehicle stability on tangent track and on track that is curved less than 1 degree.
- (ii) Gage narrowing ( $a_2$ ): This segment contains an alinement deviation on one rail to reduce the gage from the nominal value to the minimum permissible gage or maximum alinement (whichever comes first).
- (iii) Gage widening ( $a_3$ ): This segment contains an alinement deviation on one rail to increase the gage from the nominal value to the maximum permissible gage or maximum alinement (whichever comes first).
- (iv) Repeated surface ( $a_9$ ): This segment contains three consecutive maximum permissible profile variations on each rail.
- (v) Repeated alinement ( $a_4$ ): This segment contains two consecutive maximum permissible alinement variations on each rail.
- (vi) Single surface ( $a_{10}$ ,  $a_{11}$ ): This segment contains a maximum permissible profile variation on one rail. If the maximum permissible profile variation alone produces a condition which exceeds the maximum allowed warp condition, a second profile variation is also placed on the opposite rail to limit the warp to the maximum permissible

value.

- (vii) *Single alinement (a5, a6): This segment contains a maximum permissible alinement variation on one rail. If the maximum permissible alinement variation alone produces a condition which exceeds the maximum allowed gage condition, a second alinement variation is also placed on the opposite rail to limit the gage to the maximum permissible value.*
- (viii) *Short warp (a12): This segment contains a pair of profile deviations to produce a maximum permissible 10-foot warp perturbation. The first is on the outside rail, and the second follows 10 feet farther on the inside rail. Each deviation has a wavelength,  $\lambda$ , of 20 feet and variable amplitude for each simulation speed as described below. This segment is to be used only on curved track simulations.*
- (ix) *Combined perturbation (a7, a8, a13): This segment contains a maximum permissible down and out combined geometry condition on the outside rail in the body of the curve. If the maximum permissible variations produce a condition which exceeds the maximum allowed gage condition, a second variation is also placed on the opposite rail as for the MCAT segments described in paragraphs (b)(1)(vi) and (vii) of this appendix. This segment is to be used for all simulations on Class 9 track, and only for curved track simulations at speeds producing more than 5 inches of cant deficiency on track Classes 6 through 8, and at speeds producing more than 6 inches of cant deficiency on track Classes 1 through 5.*

**Guidance:** This paragraph 2(b)(1) describes characteristics of each MCAT segment. Attention need to be paid when using track geometry data from various measurement systems. The data format may have different sign designations for surface and alignment deviations. For example, in FRA's TGMS system, the alignment perturbation that reduces the gage has negative value for the left rail and positive value for the right rail, referencing the traveling direction of track inspection car.

Paragraph (b)(1)(i) makes clear that the hunting perturbation segment applies both to tangent track and to track that is curved less than 1 degree. Figure 1 and the text in paragraph (b)(1)(i) reference curvature conditions under which the hunting segment is to be used. Since the curvature value is calculated using a combination of speed and cant deficiency, there is no need to specify which track classes need to include this section in curving simulations.

The amplitude of 0.25 inch of hunting perturbation *a1* will ensure vehicle stability on tangent track. At this limit, wheel contact should stay on the tread, and the ability of the vehicle to remain stable and resist hunting can appropriately be examined.

Paragraph (b)(1)(ix) makes clear that the combined perturbation segment is to be used for all simulations on Class 9 track. Figure 1 also reflects application of the combined perturbations segment to tangent cases on Class 9 track. These provisions make this appendix consistent with § 213.332.

- (2) *Segment lengths: Each MCAT segment shall be long enough to allow the vehicle's response to the track deviation(s) to damp out. Each segment shall also have a minimum length as specified in table 1 of this appendix, which references the distances in figure 1 of this appendix. For curved track segments, the perturbations shall be placed far enough in the body of the curve to allow for any spiral effects to damp out.*

**Table 1 of Appendix D to Part 213**  
**Minimum Lengths of MCAT Segments**

<b>Distances (ft)</b>								
<b><i>d</i><sub>1</sub></b>	<b><i>d</i><sub>2</sub></b>	<b><i>d</i><sub>3</sub></b>	<b><i>d</i><sub>4</sub></b>	<b><i>d</i><sub>5</sub></b>	<b><i>d</i><sub>6</sub></b>	<b><i>d</i><sub>7</sub></b>	<b><i>d</i><sub>8</sub></b>	<b><i>d</i><sub>9</sub></b>
1000	1000	1000	1500	1000	1000	1000	1000	1000

**Guidance:** Paragraph (b)(2) specifies the required length of MCAT segments. Table 1 lists the minimum lengths of each MCAT segment.

Longer segment lengths can be used at higher speeds to allow for transient response to dissipate and to ensure that the filtering window does not extend to the next MCAT segment.

(3) *Degree of curvature.*

(i) *For each simulation involving assessment of curving performance, the degree of curvature, D, which generates a particular level of cant deficiency, E<sub>u</sub>, for a given speed, V, shall be calculated using the following equation, which assumes a curve with 6 inches of superelevation:*

$$D = \frac{6 + E_u}{0.0007 \times V^2}$$

Where—

*D = Degree of curvature (degrees).*

*V = Simulation speed (m.p.h.).*

*E<sub>u</sub> = Cant deficiency (inches).*

(ii) *Table 2 of this appendix depicts the degree of curvature for use in MCAT simulations of both passenger and freight equipment performance on Class 2 through 9 track, based on the equation in paragraph (b)(3)(i) of this appendix. The degree of curvature for use in MCAT simulations of equipment performance on Class 1 track is not depicted; it would be based on the same equation using an appropriate superelevation. The degree of curvature for use in MCAT simulations of freight equipment performance on Class 6 (freight) track is shown in italics for cant deficiencies not exceeding 6 inches, to emphasize that the values apply to freight equipment only.*

**Guidance:** Paragraph (b)(3) concerns degree of curvature for use in MCAT simulations of both passenger and freight equipment performance on Class 2 through 9 track by speed and cant deficiency. Paragraph (b)(3)(i) gives the equation to compute curvature, which is a different form of the  $V_{max}$  equation in §§ 213.57 and 213.329.

Paragraph (b)(3)(i) contains the newly added Table 2 that gives the applicable curvature for different track classes and cant deficiency, based on the equation in paragraph (b)(3)(i) of this appendix.

For track Classes 2 through 5, degrees of curvature are identified only where the cant deficiencies are more than 6 inches, since those are the only cant deficiencies that require simulations for such track classes. Degrees of curvature for use in MCAT simulations of equipment performance on Class 1 track are not specified because extraordinarily high values of curvature would correspond to such cant deficiencies, which are not physically practical to allow any rail vehicle to traverse. The highest curvature existing in the U.S. rail system is approximately 20 degrees. Nonetheless, FRA intends that degrees of curvature for Class 1 track be based on the same equation in paragraph (b)(3)(i) using an appropriate superelevation.

FRA also notes that the degrees of curvature for use in MCAT simulations of freight equipment performance on Class 6 (freight) track for speeds of 85 and 90 m.p.h. is shown in italics for cant deficiencies not exceeding 6 inches, to emphasize that these values apply to freight equipment only. MCAT simulations are required for both passenger and freight equipment performance where track Class 6 speeds coincide, i.e., speeds exceeding 90 m.p.h.

**Table 2 of Appendix D to Part 213  
Degree of Curvature for Use in MCAT Simulations (Track Classes 2 through 9)**

		Tangent	Cant Deficiency (inches)									
			3	4	5	6	7	8	9			
Passenger	m.p.h.	Degree of curvature used in simulations								m.p.h.	Freight	
Class 2	20							46.4	50.0	53.6	20	Class 2
	25							29.7	32.0	34.3	25	
	30							20.6	22.2	23.8	30	
Class 3	35							15.2	16.3	17.5	35	Class 3
	40							11.6	12.5	13.4	40	
	45							9.17	9.88	10.6	45	Class 4
	50							7.43	8.00	8.57	50	
	55							6.14	6.61	7.08	55	
Class 4	60							5.16	5.56	5.95	60	Class 5
	65							4.40	4.73	5.07	65	
	70							3.79	4.08	4.37	70	
	75							3.30	3.56	3.81	75	
Class 5	80							2.90	3.13	3.35	80	Class 6
	85	0.00	1.78	1.98	2.18	2.37	2.57	2.77	2.97	85		
Class 6	90	0.00	1.59	1.76	1.94	2.12	2.29	2.47	2.65	90	Class 6	
	95	0.00	1.42	1.58	1.74	1.90	2.06	2.22	2.37	95		
	100	0.00	1.29	1.43	1.57	1.71	1.86	2.00	2.14	100		
	105	0.00	1.17	1.30	1.43	1.55	1.68	1.81	1.94	105		
Class 7	110	0.00	1.06	1.18	1.30	1.42	1.53	1.65	1.77	110	Class 7	
	115	0.00	0.97	1.08	1.19	1.30	1.40	1.51	1.62	115		
	120	0.00	0.89	0.99	1.09	1.19	1.29	1.39	1.49	120		
Class 8	125	0.00	0.82	0.91	1.01	1.10	1.19	1.28	1.37	125	Class 8	
	130	0.00	0.76	0.85	0.93	1.01	1.10	1.18	1.27	130		
	135	0.00	0.71	0.78	0.86	0.94	1.02	1.10	1.18	135		
	140	0.00	0.66	0.73	0.80	0.87	0.95	1.02	1.09	140		
	145	0.00	0.61	0.68	0.75	0.82	0.88	0.95	1.02	145		
	150	0.00	0.57	0.63	0.70	0.76	0.83	0.89	0.95	150		
	155	0.00	0.54	0.59	0.65	0.71	0.77	0.83	0.89	155		
Class 9	160	0.00	0.50	0.56	0.61	0.67	0.73	0.78	0.84	160	Class 9	
	165	0.00	0.47	0.52	0.58	0.63	0.68	0.73	0.79	165		
	170	0.00	0.44	0.49	0.54	0.59	0.64	0.69	0.74	170		
	175	0.00	0.42	0.47	0.51	0.56	0.61	0.65	0.70	175		
	180	0.00	0.40	0.44	0.49	0.53	0.57	0.62	0.66	180		
	185	0.00	0.38	0.42	0.46	0.50	0.54	0.58	0.63	185		

190	0.00	0.36	0.40	0.44	0.47	0.51	0.55	0.59	190
195	0.00	0.34	0.38	0.41	0.45	0.49	0.53	0.56	195
200	0.00	0.32	0.36	0.39	0.43	0.46	0.50	0.54	200
205	0.00	0.31	0.34	0.37	0.41	0.44	0.48	0.51	205
210	0.00	0.29	0.32	0.36	0.39	0.42	0.45	0.49	210
215	0.00	0.28	0.31	0.34	0.37	0.40	0.43	0.46	215
220	0.00	0.27	0.30	0.32	0.35	0.38	0.41	0.44	220

(c) *Required simulations.*

(1) *To develop a comprehensive assessment of vehicle performance, simulations shall be performed for a variety of scenarios using MCAT. These simulations shall be performed on tangent or curved track, or both, depending on the level of cant deficiency and speed (track class) as summarized in table 3 of this appendix.*

**Table 3 of Appendix D to Part 213  
Summary of Required Vehicle Performance Assessment Using Simulations**

	<i>New vehicle types</i>	<i>Previously qualified vehicle types</i>
<i>Curved track: cant deficiency ≤ 6 inches</i>	<i>Curving performance simulation: not required for track Classes 1 through 5; optional for track Class 6; required for track Classes 7 through 9</i>	<i>Curving performance simulation: not required for track Classes 1 through 6; optional for track Classes 7 through 9 for cant deficiency &gt; 5 inches</i>
<i>Curved track: cant deficiency &gt; 6 inches</i>	<i>Curving performance simulation required for all track classes</i>	<i>Curving performance simulation optional for all track classes</i>
<i>Tangent track</i>	<i>Tangent performance simulation: not required for track Classes 1 through 5; optional for track Class 6; required for track Classes 7 through 9</i>	<i>Tangent performance simulation not required for any track class</i>

(i) *All simulations shall be performed using the design wheel profile and a nominal track gage of 56.5 inches, using tables 4, 5, 6, or 7 of this appendix, as appropriate. In addition, all simulations involving the assessment of curving performance shall be repeated using a nominal track gage of 57.0 inches, using tables 5, 6, or 7 of this appendix, as appropriate.*

(ii) *If the wheel profile is different than American Public Transportation Administration (APTA) wheel profiles 320 or 340, then for tangent track segments all simulations shall be repeated using either APTA wheel profile 320 or 340, depending on the established conicity that is common for the operation, as specified in APTA SS-M-015-06, Standard for Wheel Flange Angle of Passenger Equipment (2007). This APTA standard is incorporated by reference into this appendix with the approval of the Director of the Federal Register under 5 U.S.C. 552(a) and 1 CFR part 51. To enforce any edition other than that specified in this appendix, FRA must publish notice of change in the Federal Register and the material must be made available to the public. All approved material is available for inspection at the Federal Railroad Administration, Docket Clerk, 1200 New Jersey Avenue, SE., Washington, DC 20590 (telephone 202-493-*



6030), and is available from the American Public Transportation Association, 1666 K Street NW., Suite 1100, Washington, DC 20006 (telephone 202-496-4800; [www.apta.com](http://www.apta.com)). It is also available for inspection at the National Archives and Records Administration (NARA). For information on the availability of this material at NARA, call 202-741-6030 or go to [http://www.archives.gov/federal\\_register/code\\_of\\_federal\\_regulations/ibr\\_locations.html](http://www.archives.gov/federal_register/code_of_federal_regulations/ibr_locations.html)

An alternative worn wheel profile may be used in lieu of either APTA wheel profile, if approved by FRA.

(iii) All simulations shall be performed using a wheel/rail coefficient of friction of 0.5.

**Guidance:** Paragraph (c) identifies and describes the simulations that are required using MCAT. Table 3 summarizes the requirements by vehicle type, cant deficiency, and class of track when assessments of vehicle performance using MCAT.

The rule makes explicit when simulations are required, including identifying when simulations are an option for demonstrating compliance with the rule.

Paragraph (c)(1)(ii) addresses the use of worn wheel profiles in simulations.

Simulations using worn wheels will be conducted only for tangent track segments. Worn wheel profiles can both present a problem for stability on tangent track and affect response during curving. However, the effect of wheel wear on stability on tangent track is of paramount concern. For all other vehicle and rail parameters that might equally or more significantly affect response during curving, only nominal values for such parameters are required to be used in MCAT simulations. Therefore, it is not required that simulations be conducted with worn wheel profiles in curves.

*(2) Vehicle performance on tangent track Classes 6 through 9. For maximum vehicle speeds corresponding to track Class 6 and higher, the MCAT segments described in paragraphs (b)(1)(i) through (vii) of this appendix shall be used to assess vehicle performance on tangent track. For track Class 9, simulations must also include the combined perturbation segment described in paragraph (b)(1)(ix) of this appendix. A parametric matrix of MCAT simulations shall be performed using the following range of conditions:*

*(i) Vehicle speed. Simulations shall demonstrate that at up to 5 m.p.h. above the proposed maximum operating speed, the vehicle type shall not exceed the wheel/rail force and acceleration criteria defined in the Vehicle/Track Interaction Safety Limits table in § 213.333. Simulations shall also demonstrate acceptable vehicle dynamic response by incrementally increasing speed from 95 m.p.h. (115 m.p.h. if a previously qualified vehicle type on an untested route) to 5 m.p.h. above the proposed maximum operating speed (in 5 m.p.h. increments).*

*(ii) Perturbation wavelength. For each speed, a set of three separate MCAT simulations shall be performed. In each MCAT simulation for the perturbation segments described in paragraphs (b)(1)(ii) through (vii) and (b)(1)(ix) of this appendix, every perturbation shall have the same wavelength. The following three wavelengths,  $\lambda$ , shall be used: 31, 62, and 124 feet. The hunting perturbation segment described in paragraph (b)(1)(i) of this appendix has a fixed wavelength,  $\lambda$ , of 10 feet.*

*(iii) Amplitude parameters. Table 4 of this appendix provides the amplitude values for the MCAT segments described in paragraphs (b)(1)(i) through (vii) and (b)(1)(ix) of this appendix for each speed of the required parametric MCAT simulations. The last set of simulations shall be*

*performed at 5 m.p.h. above the proposed maximum operating speed using the amplitude values in table 4 that correspond to the proposed maximum operating speed. For qualification of vehicle types at speeds greater than track Class 6 speeds, the following additional simulations shall be performed:*

*(A) For vehicle types being qualified for track Class 7 speeds, one additional set of simulations shall be performed at 115 m.p.h. using the track Class 6 amplitude values in table 4 (i.e., a 5 m.p.h. overspeed on Class 6 track).*

*(B) For vehicle types being qualified for track Class 8 speeds, two additional sets of simulations shall be performed. The first set at 115 m.p.h. using the track Class 6 amplitude values in table 4 (i.e., a 5 m.p.h. overspeed on Class 6 track), and a second set at 130 m.p.h. using the track Class 7 amplitude values in table 4 (i.e., a 5 m.p.h. overspeed on Class 7 track).*

*(C) For vehicle types being qualified for track Class 9 speeds, three additional sets of simulations shall be performed. The first set at 115 m.p.h. using the track Class 6 amplitude values in table 4 (i.e., a 5 m.p.h. overspeed on Class 6 track), a second set at 130 m.p.h. using the track Class 7 amplitude values in table 4 (i.e., a 5 m.p.h. overspeed on Class 7 track), and a third set at 165 m.p.h. using the track Class 8 amplitude values in table 4 (i.e., a 5 m.p.h. overspeed on Class 8 track).*

**Table 4 of Appendix D to Part 213  
Track Class 6 through 9 Amplitude Parameters (in inches)  
for MCAT Simulations on Tangent Track**

		<b>Gage 56.5"</b>				
		<b>Class 6</b>	<b>Class 7</b>	<b>Class 8</b>	<b>Class 9</b>	
<i>Max. Operating Speed (m.p.h.)</i>		110	125	160	220	
<i>Max. Simulation Speed (m.p.h.)</i>		115	130	165	225	
<b>MCAT Segments</b>	<b>Parame</b>	<b>Segment Description</b>				
<i>Hunting</i>	<i>a<sub>1</sub></i>	<i>(b)(1)(i)</i>				
<i>Gage Narrowing</i>	<i>a<sub>2</sub></i>	<i>(b)(1)(ii)</i>				
<i>Gage Widening</i>	<i>a<sub>3</sub></i>	<i>(b)(1)(iii)</i>				
<i>Repeated Surface</i>	<i>a<sub>9</sub></i>	<i>(b)(1)(iv)</i>				
<i>Repeated Alinement</i>	<i>a<sub>4</sub></i>	<i>(b)(1)(v)</i>				
<i>Single Surface</i>	<i>a<sub>10</sub>, a<sub>11</sub></i>	<i>(b)(1)(vi)</i>				
<i>Single Alinement</i>	<i>a<sub>5</sub>, a<sub>6</sub></i>	<i>(b)(1)(vii)</i>				
<i>Short Warp</i>	<i>a<sub>12</sub></i>					
<i>Combined Perturbation</i>	<i>a<sub>7</sub>, a<sub>8</sub></i>	<i>(b)(1)(ix)</i>				
		<b>Amplitude Parameters (inches)</b>				
<b>Wavelength <math>\lambda = 10ft</math></b>		<i>a<sub>1</sub></i>	0.250	0.250	0.250	0.250
<b>Wavelength <math>\lambda = 20ft</math></b>		<i>a<sub>12</sub></i>				
<b>Wavelength <math>\lambda = 31ft</math></b>	<i>a<sub>2</sub></i>	0.500	0.500	0.500	0.250	
	<i>a<sub>3</sub></i>	0.750	0.500	0.500	0.500	
	<i>a<sub>4</sub></i>	0.375	0.375	0.375	0.375	
	<i>a<sub>5</sub></i>	0.500	0.500	0.500	0.500	
	<i>a<sub>6</sub></i>	0.000	0.000	0.000	0.000	
	<i>a<sub>7</sub></i>				0.333	
	<i>a<sub>8</sub></i>				0.000	
	<i>a<sub>9</sub></i>	0.750	0.750	0.500	0.375	
	<i>a<sub>10</sub></i>	1.000	1.000	0.750	0.500	
	<i>a<sub>11</sub></i>	0.000	0.000	0.000	0.000	
	<i>a<sub>13</sub></i>				0.333	
	<b>Wavelength <math>\lambda = 62ft</math></b>	<i>a<sub>2</sub></i>	0.500	0.500	0.500	0.250
		<i>a<sub>3</sub></i>	0.750	0.500	0.500	0.500
<i>a<sub>4</sub></i>		0.500	0.375	0.375	0.375	
<i>a<sub>5</sub></i>		0.750	0.750	0.750	0.500	
<i>a<sub>6</sub></i>		0.000	0.250	0.250	0.000	
<i>a<sub>7</sub></i>					0.333	
<i>a<sub>8</sub></i>					0.000	
<i>a<sub>9</sub></i>		0.750	0.750	0.750	0.500	
<i>a<sub>10</sub></i>		1.000	1.000	1.000	0.750	
<i>a<sub>11</sub></i>		0.000	0.000	0.000	0.000	
<i>a<sub>13</sub></i>					0.500	
<b>Wavelength <math>\lambda = 124ft</math></b>		<i>a<sub>2</sub></i>	0.500	0.500	0.500	0.250
		<i>a<sub>3</sub></i>	0.750	0.750	0.750	0.750
	<i>a<sub>4</sub></i>	1.000	0.875	0.500	0.500	
	<i>a<sub>5</sub></i>	1.500	1.250	1.000	0.750	
	<i>a<sub>6</sub></i>	0.750	0.500	0.250	0.000	
	<i>a<sub>7</sub></i>				0.500	
	<i>a<sub>8</sub></i>				0.000	
	<i>a<sub>9</sub></i>	1.250	1.000	0.875	0.625	
	<i>a<sub>10</sub></i>	1.750	1.500	1.250	1.000	
	<i>a<sub>11</sub></i>	0.250	0.000	0.000	0.000	
	<i>a<sub>13</sub></i>				0.667	

**Guidance:** Paragraph (c)(2) addresses vehicle performance on tangent track Classes 6 through

9. The text in paragraphs (c)(2)(ii) and (iii) describes the simulation parameters, i.e., wavelength and amplitude listed in Table 4.

Table 4 in the paragraph provides the amplitude values for the MCAT segments described in paragraphs (b)(1)(i) through (vii) and, for track Class 9, (b)(1)(ix), for each speed of the required parametric MCAT simulations.

The header table contains the maximum operating and simulation speeds for each track class, along with a list of all of the amplitude parameters identifying each MCAT segment to which they correspond, where each segment description can be found, and to which class(es) of track they are applicable.

*(3) Vehicle performance on curved track Classes 6 through 9. For maximum vehicle speeds corresponding to track Class 6 and higher, the MCAT segments described in paragraphs (b)(1)(ii) through (viii) of this appendix shall be used to assess vehicle performance on curved track. For curves less than 1 degree, simulations must also include the hunting perturbation segment described in paragraph (b)(1)(i) of this appendix. For track Class 9 and for cant deficiencies greater than 5 inches, simulations must also include the combined perturbation segment described in paragraph (b)(1)(ix) of this appendix. A parametric matrix of MCAT simulations shall be performed using the following range of conditions:*

*(i) Vehicle speed. Simulations shall demonstrate that at up to 5 m.p.h. above the proposed maximum operating speed, the vehicle type shall not exceed the wheel/rail force and acceleration criteria defined in the Vehicle/Track Interaction Safety Limits table in § 213.333. Simulations shall also demonstrate acceptable vehicle dynamic response by incrementally increasing speed from 95 m.p.h. (115 m.p.h. if a previously qualified vehicle type on an untested route) to 5 m.p.h. above the proposed maximum operating speed (in 5 m.p.h. increments).*

*(ii) Perturbation wavelength. For each speed, a set of three separate MCAT simulations shall be performed. In each MCAT simulation for the perturbation segments described in paragraphs (b)(1)(ii) through (vii) and paragraph (b)(1)(ix) of this appendix, every perturbation shall have the same wavelength. The following three wavelengths,  $\lambda$ , shall be used: 31, 62, and 124 feet. The hunting perturbation segment described in paragraph (b)(1)(i) of this appendix has a fixed wavelength,  $\lambda$ , of 10 feet, and the short warp perturbation segment described in paragraph (b)(1)(viii) of this appendix has a fixed wavelength,  $\lambda$ , of 20 feet.*

*(iii) Track curvature. For each speed, a range of curvatures shall be used to produce cant deficiency conditions ranging from greater than 3 inches up to the maximum intended for qualification (in 1 inch increments). The value of curvature,  $D$ , shall be determined using the equation defined in paragraph (b)(3) of this appendix. Each curve shall include representations of the MCAT segments described in paragraphs (b)(1)(i) through (ix) of this appendix, as appropriate, and have a fixed superelevation of 6 inches.*

*(iv) Amplitude parameters. Table 5 of this appendix provides the amplitude values for each speed of the required parametric MCAT simulations for cant deficiencies greater than 3 inches and not more than 5 inches. Table 6 of this appendix provides the amplitude values for each speed of the required parametric MCAT simulations for cant deficiencies greater than 5 inches. The last set of simulations at the maximum cant deficiency shall be performed at 5 m.p.h. above the proposed maximum operating speed using the amplitude values in table 5 or 6 of this appendix, as appropriate, that correspond to the proposed maximum operating speed and cant deficiency. For these simulations, the value of curvature,  $D$ , shall correspond to the proposed maximum operating speed and cant deficiency. For qualification of vehicle types at speeds*

*greater than track Class 6 speeds, the following additional simulations shall be performed:*

*(A) For vehicle types being qualified for track Class 7 speeds, one additional set of simulations shall be performed at 115 m.p.h. using the track Class 6 amplitude values in table 5 or 6 of this appendix, as appropriate (i.e., a 5 m.p.h. overspeed on Class 6 track) and a value of curvature,  $D$ , that corresponds to 110 m.p.h. and the proposed maximum cant deficiency.*

*(B) For vehicle types being qualified for track Class 8 speeds, two additional set of simulations shall be performed. The first set of simulations shall be performed at 115 m.p.h. using the track Class 6 amplitude values in table 5 or 6 of this appendix, as appropriate (i.e., a 5 m.p.h. overspeed on Class 6 track) and a value of curvature,  $D$ , that corresponds to 110 m.p.h. and the proposed maximum cant deficiency. The second set of simulations shall be performed at 130 m.p.h. using the track Class 7 amplitude values in table 5 or 6, as appropriate (i.e., a 5 m.p.h. overspeed on Class 7 track) and a value of curvature,  $D$ , that corresponds to 125 m.p.h. and the proposed maximum cant deficiency.*

*(C) For vehicle types being qualified for track Class 9 speeds, three additional sets of simulations shall be performed. The first set of simulations shall be performed at 115 m.p.h. using the track Class 6 amplitude values in table 5 or 6 of this appendix, as appropriate (i.e., a 5 m.p.h. overspeed on Class 6 track) and a value of curvature,  $D$ , that corresponds to 110 m.p.h. and the proposed maximum cant deficiency. The second set of simulations shall be performed at 130 m.p.h. using the track Class 7 amplitude values in table 5 or 6, as appropriate (i.e., a 5 m.p.h. overspeed on Class 7 track) and a value of curvature,  $D$ , that corresponds to 125 m.p.h. and the proposed maximum cant deficiency. The third set of simulations shall be performed at 165 m.p.h. using the track Class 8 amplitude values in table 5 or 6, as appropriate (i.e., a 5 m.p.h. overspeed on Class 8 track) and a value of curvature,  $D$ , that corresponds to 160 m.p.h. and the proposed maximum cant deficiency.*

**Table 5 of Appendix D to Part 213  
Track Classes 6 through 9 Amplitude Parameters (in inches)  
for MCAT Simulations on Curved Track with Cant Deficiency > 3 and ≤ 5 Inches**

		Gage 56.5"				Gage 57.0"				
		Class	Class	Class	Class	Class	Class	Class	Class 9	
Max. Operating Speed (m.p.h.)		110	125	160	220	110	125	160	220	
Max. Simulation Speed (m.p.h.)		115	130	165	225	115	130	165	225	
MCAT Segments	Parameter	Segment Description				Segment Description				
Hunting	a <sub>1</sub>	(b)(1)(i) <sup>1</sup>				(b)(1)(i) <sup>1</sup>				
Gage Narrowing	a <sub>2</sub>	(b)(1)(ii)				(b)(1)(ii)				
Gage Widening	a <sub>3</sub>	(b)(1)(iii)				(b)(1)(iii)				
Repeated Surface	a <sub>9</sub>	(b)(1)(iv)				(b)(1)(iv)				
Repeated Alinement	a <sub>4</sub>	(b)(1)(v)				(b)(1)(v)				
Single Surface	a <sub>10</sub> , a <sub>11</sub>	(b)(1)(vi)				(b)(1)(vi)				
Single Alinement	a <sub>5</sub> , a <sub>6</sub>	(b)(1)(vii)				(b)(1)(vii)				
Short Warp	a <sub>12</sub>	(b)(1)(viii)				(b)(1)(viii)				
Combined	a <sub>7</sub> , a <sub>8</sub>	(b)(1)(i)				(b)(1)(ix)				
		Amplitude Parameters				Amplitude Parameters (inches)				
Wavelength λ =	a <sub>1</sub>	0.250	0.250 <sup>1</sup>	0.250 <sup>1</sup>	0.250 <sup>1</sup>	0.250	0.250 <sup>1</sup>	0.250 <sup>1</sup>	0.250 <sup>1</sup>	
Wavelength λ =	a <sub>12</sub>	0.625	0.563	0.500	0.375	0.625	0.563	0.500	0.375	
Wavelength λ = 31ft	a <sub>2</sub>	0.500	0.500	0.500	0.250	0.500	0.500	0.500	0.500	
	a <sub>3</sub>	0.750	0.500	0.500	0.500	0.500	0.500	0.500	0.500	
	a <sub>4</sub>	0.375	0.375	0.375	0.375	0.375	0.375	0.375	0.375	
	a <sub>5</sub>	0.500	0.500	0.500	0.500	0.500	0.500	0.500	0.500	
	a <sub>6</sub>	0.000	0.000	0.000	0.000	0.250	0.250	0.250	0.250	
	a <sub>7</sub>				0.333				0.333	
	a <sub>8</sub>				0.000				0.083	
	a <sub>9</sub>	0.750	0.750	0.500	0.375	0.750	0.750	0.500	0.375	
	a <sub>10</sub>	1.000	1.000	0.750	0.500	1.000	1.000	0.750	0.500	
	a <sub>11</sub>	0.000	0.000	0.000	0.000	0.000	0.000	0.000	0.000	
	a <sub>13</sub>				0.333				0.333	
	Wavelength λ = 62ft	a <sub>2</sub>	0.500	0.500	0.500	0.250	0.500	0.500	0.500	0.500
		a <sub>3</sub>	0.750	0.500	0.500	0.500	0.250	0.250	0.250	0.250
a <sub>4</sub>		0.500	0.375	0.375	0.375	0.500	0.375	0.375	0.375	
a <sub>5</sub>		0.625	0.500	0.500	0.500	0.625	0.500	0.500	0.500	
a <sub>6</sub>		0.000	0.000	0.000	0.000	0.375	0.250	0.250	0.250	
a <sub>7</sub>					0.333				0.333	
a <sub>8</sub>					0.000				0.083	
a <sub>9</sub>		0.750	0.750	0.750	0.500	0.750	0.750	0.750	0.500	
a <sub>10</sub>		1.000	1.000	1.000	0.750	1.000	1.000	1.000	0.750	
a <sub>11</sub>		0.000	0.000	0.000	0.000	0.000	0.000	0.000	0.000	
a <sub>13</sub>					0.500				0.500	
Wavelength λ = 124ft		a <sub>2</sub>	0.500	0.500	0.500	0.250	1.000	1.000	1.000	0.750
		a <sub>3</sub>	0.750	0.750	0.750	0.750	0.250	0.250	0.250	0.250
	a <sub>4</sub>	1.000	0.875	0.500	0.500	1.000	0.875	0.500	0.500	
	a <sub>2</sub>	1.500	1.250	0.750	0.750	1.500	1.250	0.750	0.750	
	a <sub>6</sub>	0.750	0.500	0.000	0.000	1.250	1.000	0.500	0.500	
	a <sub>7</sub>				0.500				0.500	
	a <sub>8</sub>				0.000				0.250	
	a <sub>9</sub>	1.250	1.000	0.875	0.625	1.250	1.000	0.875	0.625	
	a <sub>10</sub>	1.750	1.500	1.250	1.000	1.750	1.500	1.250	1.000	
	a <sub>11</sub>	0.250	0.000	0.000	0.000	0.250	0.000	0.000	0.000	
	a <sub>13</sub>				0.667				0.667	

<sup>1</sup> For curves <1 degree

**Table 6 of Appendix D to Part 213  
Track Class 6 through 9 Amplitude Parameters (in inches)  
for MCAT Simulations on Curved Track with Cant Deficiency > 5 Inches**

		Gage 56.5"				Gage 57.0"			
		Class	Class	Class	Class	Class 6	Class	Class 8	Class 9
Max. Operating Speed (m.p.h.)		110	125	160	220	110	125	160	220
Max. Simulation Speed (m.p.h.)		115	130	165	225	115	130	165	225
MCAT Segments	Paramet	Segment Description							
Hunting	a <sub>1</sub>	(b)(1)(i) <sup>1</sup>							
Gage Narrowing	a <sub>2</sub>	(b)(1)(ii)							
Gage Widening	a <sub>3</sub>	(b)(1)(iii)							
Repeated Surface	a <sub>9</sub>	(b)(1)(iv)							
Repeated Alinement	a <sub>4</sub>	(b)(1)(v)							
Single Surface	a <sub>10</sub> , a <sub>11</sub>	(b)(1)(vi)							
Single Alinement	a <sub>5</sub> , a <sub>6</sub>	(b)(1)(vii)							
Short Warp	a <sub>12</sub>	(b)(1)(viii)							
Combined	a <sub>7</sub> , a <sub>8</sub> ,								(b)(1)(ix)
		Amplitude Parameters (inches)				Amplitude Parameters (inches)			
Wavelength λ = 10ft	a <sub>1</sub>	0.250 <sup>1</sup>	0.250 <sup>1</sup>	0.250 <sup>1</sup>	0.250 <sup>1</sup>	0.250 <sup>1</sup>	0.250 <sup>1</sup>	0.250 <sup>1</sup>	0.250 <sup>1</sup>
Wavelength λ = 20ft	a <sub>12</sub>	0.625	0.500	0.500 <sup>2</sup>	0.375	0.625	0.500	0.500 <sup>2</sup>	0.375
Wavelength λ = 31ft	a <sub>2</sub>	0.500	0.500	0.500	0.250	0.500	0.500	0.500	0.500
	a <sub>3</sub>	0.750	0.500	0.500	0.500	0.250	0.250	0.250	0.500
	a <sub>4</sub>	0.375	0.375	0.375	0.375	0.375	0.375	0.375	0.375
	a <sub>5</sub>	0.500	0.500	0.500	0.500	0.500	0.500	0.500	0.500
	a <sub>6</sub>	0.000	0.000	0.000	0.000	0.250	0.250	0.250	0.250
	a <sub>7</sub>	0.333	0.333	0.333	0.333	0.333	0.333	0.333	0.333
	a <sub>8</sub>	0.000	0.000	0.000	0.000	0.083	0.083	0.083	0.083
	a <sub>9</sub>	0.750	0.750	0.500	0.375	0.750	0.750	0.500	0.375
	a <sub>10</sub>	1.000	1.000	0.750	0.500	1.000	1.000	0.750	0.500
	a <sub>11</sub>	0.000	0.000	0.000	0.000	0.000	0.000	0.000	0.000
Wavelength λ = 62ft	a <sub>13</sub>	0.667	0.667	0.500	0.333	0.667	0.667	0.500	0.333
	a <sub>2</sub>	0.500	0.500	0.500	0.250	0.500	0.500	0.500	0.500
	a <sub>3</sub>	0.750	0.500	0.500	0.500	0.250	0.250	0.250	0.250
	a <sub>4</sub>	0.500	0.375	0.375	0.375	0.500	0.375	0.375	0.375
	a <sub>5</sub>	0.625	0.500	0.500	0.500	0.625	0.500	0.500	0.500
	a <sub>6</sub>	0.000	0.000	0.000	0.000	0.375	0.250	0.250	0.250
	a <sub>7</sub>	0.417	0.333	0.333	0.333	0.417	0.333	0.333	0.333
	a <sub>8</sub>	0.000	0.000	0.000	0.000	0.167	0.083	0.083	0.083
	a <sub>9</sub>	0.750	0.750	0.750	0.500	0.750	0.750	0.750	0.500
	a <sub>10</sub>	1.000	1.000	1.000	0.750	1.000	1.000	1.000	0.750
Wavelength λ = 124ft	a <sub>11</sub>	0.000	0.000	0.000	0.000	0.000	0.000	0.000	0.000
	a <sub>13</sub>	0.667	0.667	0.667	0.500	0.667	0.667	0.667	0.500
	a <sub>2</sub>	0.500	0.500	0.500	0.250	1.000	1.000	1.000	0.750
	a <sub>3</sub>	0.750	0.750	0.750	0.750	0.250	0.250	0.250	0.250
	a <sub>4</sub>	1.000	0.875	0.500	0.500	1.000	0.875	0.500	0.500
	a <sub>5</sub>	1.250	1.000	0.750	0.750	1.250	1.000	0.750	0.750
	a <sub>6</sub>	0.500	0.250	0.000	0.000	1.000	0.750	0.500	0.500
	a <sub>7</sub>	0.833	0.667	0.500	0.500	0.833	0.667	0.500	0.500
	a <sub>8</sub>	0.083	0.000	0.000	0.000	0.583	0.417	0.250	0.250
	a <sub>9</sub>	1.250	1.000	0.875	0.625	1.250	1.000	0.875	0.625
a <sub>10</sub>	1.500	1.250	1.250	1.000	1.500	1.250	1.250	1.000	
a <sub>11</sub>	0.000	0.000	0.000	0.000	0.000	0.000	0.000	0.000	
a <sub>13</sub>	1.000	0.833	0.833	0.667	1.000	0.833	0.833	0.667	

<sup>1</sup> For curves <1 degree

<sup>2</sup> 0.375 for E<sub>u</sub>>7"

**Guidance:** Paragraph (c)(3) addresses vehicle performance on curved track Classes 6 through 9. Paragraphs (c)(3)(ii) and (iv) contain the descriptive text regarding the information in tables 5 and 6. Paragraph (c)(3)(ii) makes clear that running simulations using all three

wavelengths is a requirement. Paragraph (c)(3)(iv) specifies the need to run the final simulations at 5 m.p.h. over the maximum proposed operating speed and cant deficiency. Paragraphs (c)(3)(iv)(A) through (C) specifies that this 5 m.p.h. overspeed is required when transitioning between classes, e.g., 115 m.p.h. for Class 6 track when qualifying a vehicle for Class 7 track. In addition, the text in paragraphs (c)(3)(iv)(A) through (C) describes how the 5 m.p.h. overspeed cases at the end of a track class will be conducted at the maximum proposed cant deficiency, using the curvature value,  $D$ , calculated using the maximum track class speed and maximum proposed cant deficiency.

Table 5 applies to Class 6 through 9 curved track with cant deficiency greater than 3 inches but not greater than 5 inches; table 6 applies to Class 6 through 9 curved track with cant deficiency greater than 5 inches. Both tables contain the maximum operating and simulation speeds for each track class, along with a list of all of the amplitude parameters identifying each MCAT segment to which they correspond, where each segment description can be found, and to which class(es) of track they are applicable.

*(4) Vehicle performance on curved track Classes 1 through 5 at high cant deficiency. For maximum vehicle speeds corresponding to track Classes 1 through 5, the MCAT segments described in paragraphs (b)(1)(ii) through (ix) of this appendix shall be used to assess vehicle performance on curved track if the proposed maximum cant deficiency is greater than 6 inches. A parametric matrix of MCAT simulations shall be performed using the following range of conditions:*

*(i) Vehicle speed. Simulations shall demonstrate that at up to 5 m.p.h. above the proposed maximum operating speed, the vehicle shall not exceed the wheel/rail force and acceleration criteria defined in the Vehicle/Track Interaction Safety Limits table in § 213.333. Simulations shall also demonstrate acceptable vehicle dynamic response at 5 m.p.h. above the proposed maximum operating speed.*

*(ii) Perturbation wavelength. For each speed, a set of two separate MCAT simulations shall be performed. In each MCAT simulation for the perturbation segments described in paragraphs (b)(1)(ii) through (vii) and paragraph (b)(1)(ix) of this appendix, every perturbation shall have the same wavelength. The following two wavelengths,  $\lambda$ , shall be used: 31 and 62 feet. The short warp perturbation segment described in paragraph (b)(1)(viii) of this appendix has a fixed wavelength,  $\lambda$ , of 20 feet.*

*(iii) Track curvature. For a speed corresponding to 5 m.p.h. above the proposed maximum operating speed, a range of curvatures shall be used to produce cant deficiency conditions ranging from 6 inches up to the maximum intended for qualification (in 1 inch increments). The value of curvature,  $D$ , shall be determined using the equation in paragraph (b)(3) of this appendix. Each curve shall contain the MCAT segments described in paragraphs (b)(1)(ii) through (ix) of this appendix and have a fixed superelevation of 6 inches.*

*(iv) Amplitude parameters. Table 7 of this appendix provides the amplitude values for the MCAT segments described in paragraphs (b)(1)(ii) through (ix) of this appendix for each speed of the required parametric MCAT simulations.*



**Table 7 of Appendix D to Part 213  
Track Class 1 through 5 Amplitude Parameters (in inches)  
for MCAT Simulations on Curved Track with Cant Deficiency > 6 Inches**

		<b>Gage 56.5"</b>					<b>Gage 57.0"</b>				
		<b>Class</b>	<b>Class 2</b>	<b>Class</b>	<b>Class</b>	<b>Class 5</b>	<b>Class 1</b>	<b>Class 2</b>	<b>Class 3</b>	<b>Class 4</b>	<b>Class</b>
<i>Max. Operating Speed (m.p.h.)</i>		15	30	60	80	90	15	30	60	80	90
<i>Max. Simulation Speed (m.p.h.)</i>		20	35	65	85	95	20	35	65	85	95
<b>MCAT Segments</b>	<b>Parameter</b>	<b>Segment Description</b>					<b>Segment Description</b>				
<i>Hunting</i>	<i>a<sub>1</sub></i>										
<i>Gage Narrowing</i>	<i>a<sub>2</sub></i>	<i>(b)(1)(ii)</i>					<i>(b)(1)(ii)</i>				
<i>Gage Widening</i>	<i>a<sub>3</sub></i>	<i>(b)(1)(iii)</i>					<i>(b)(1)(iii)</i>				
<i>Repeated Surface</i>	<i>a<sub>9</sub></i>	<i>(b)(1)(iv)</i>					<i>(b)(1)(iv)</i>				
<i>Repeated Alinement</i>	<i>a<sub>4</sub></i>	<i>(b)(1)(v)</i>					<i>(b)(1)(v)</i>				
<i>Single Surface</i>	<i>a<sub>10</sub>, a<sub>11</sub></i>	<i>(b)(1)(vi)</i>					<i>(b)(1)(vi)</i>				
<i>Single Alinement</i>	<i>a<sub>5</sub>, a<sub>6</sub></i>	<i>(b)(1)(vii)</i>					<i>(b)(1)(vii)</i>				
<i>Short Warp</i>	<i>a<sub>12</sub></i>	<i>(b)(1)(viii)</i>					<i>(b)(1)(viii)</i>				
<i>Combined Perturbation</i>	<i>a<sub>7</sub>, a<sub>8</sub>, a<sub>13</sub></i>	<i>(b)(1)(ix)</i>					<i>(b)(1)(ix)</i>				
		<b>Amplitude Parameters (inches)</b>					<b>Amplitude Parameters (inches)</b>				
<b>Wavelength <math>\lambda = 10ft</math></b>	<i>a<sub>1</sub></i>										
<b>Wavelength <math>\lambda = 20ft</math></b>	<i>a<sub>12</sub></i>	1.000	1.000	0.875	0.875	0.750	1.000	1.000	0.875	0.875	0.750
<b>Wavelength <math>\lambda = 31ft</math></b>	<i>a<sub>2</sub></i>	0.500	0.500	0.500	0.500	0.500	1.250	1.250	1.250	0.500	0.500
	<i>a<sub>3</sub></i>	1.250	1.250	1.250	0.500	0.500	0.750	0.750	0.750	0.500	0.500
	<i>a<sub>4</sub></i>	0.750	0.750	0.750	0.750	0.500	0.750	0.750	0.750	0.750	0.500
	<i>a<sub>5</sub></i>	0.750	0.750	0.750	0.750	0.500	0.750	0.750	0.750	0.750	0.500
	<i>a<sub>6</sub></i>	0.000	0.000	0.000	0.250	0.000	0.000	0.000	0.000	0.250	0.000
	<i>a<sub>7</sub></i>	0.500	0.500	0.500	0.500	0.333	0.500	0.500	0.500	0.500	0.333
	<i>a<sub>8</sub></i>	0.000	0.000	0.000	0.000	0.000	0.000	0.000	0.000	0.000	0.000
	<i>a<sub>9</sub></i>	1.000	1.000	1.000	1.000	1.000	1.000	1.000	1.000	1.000	1.000
	<i>a<sub>10</sub></i>	1.000	1.000	1.000	1.000	1.000	1.000	1.000	1.000	1.000	1.000
	<i>a<sub>11</sub></i>	0.000	0.000	0.000	0.000	0.000	0.000	0.000	0.000	0.000	0.000
<b>Wavelength <math>\lambda = 62ft</math></b>	<i>a<sub>13</sub></i>	0.667	0.667	0.667	0.667	0.667	0.667	0.667	0.667	0.667	0.667
	<i>a<sub>2</sub></i>	0.500	0.500	0.500	0.500	0.500	1.250	1.250	1.250	0.500	0.500
	<i>a<sub>3</sub></i>	1.250	1.250	1.250	0.500	0.500	0.750	0.750	0.750	0.500	0.500
	<i>a<sub>4</sub></i>	1.250	1.250	1.250	0.875	0.625	1.250	1.250	1.250	0.875	0.625
	<i>a<sub>5</sub></i>	1.250	1.250	1.250	0.875	0.625	1.250	1.250	1.250	0.875	0.625
	<i>a<sub>6</sub></i>	0.000	0.000	0.000	0.375	0.125	0.500	0.500	0.500	0.375	0.125
	<i>a<sub>7</sub></i>	0.833	0.833	0.833	0.583	0.417	0.833	0.833	0.833	0.583	0.417
	<i>a<sub>8</sub></i>	0.000	0.000	0.000	0.083	0.000	0.083	0.083	0.083	0.083	0.000
	<i>a<sub>9</sub></i>	1.750	1.750	1.750	1.250	1.000	1.750	1.750	1.750	1.250	1.000
	<i>a<sub>10</sub></i>	1.750	1.750	1.750	1.250	1.000	1.750	1.750	1.750	1.250	1.000
<i>a<sub>11</sub></i>	0.000	0.000	0.000	0.000	0.000	0.000	0.000	0.000	0.000	0.000	
<i>a<sub>13</sub></i>	1.167	1.167	1.167	0.833	0.667	1.167	1.167	1.167	0.833	0.667	

**Guidance:** Paragraph (c)(4) addresses vehicle performance on curved track Classes 1 through 5 at high cant deficiency.

Paragraph (c)(4)(ii) makes it clear that running simulations using both the 31-foot and 62-foot wavelengths is required for assessing vehicle performance on curved track Classes 1 through 5 at high cant deficiency.

Table 7 contain information for Classes 1 to 5 track similar to that in tables 5 and 6 for curved track Classes 6 through 9.

(End of Volume II, Chapter 2)