

Memorandum

U.S. Department
of Transportation

Federal Railroad
Administration

Date: August 7, 2000

Reply to Attn of: MP& E 00-06

Subject: Manufacture and repair of operating platforms and operating platform safety railings on tank cars without underframes.

From: Edward E. English
Director, Office of Safety Assurance and Compliance

To: Regional Administrators, Deputy Regional Administrators, Motive Power and Equipment Specialists and Inspectors

Section 231.21(j) of title 49, Code of Federal Regulations specifies the minimum requirements for operating platforms on tank cars without underframes. However, many variations in the manufacture and repair of these platforms and the platform safety railings have been in use for a number of years, causing confusion among FRA inspectors and manufacturers as to which methods comply with Federal regulations.

In order to establish consistency within the industry, FRA hosted a committee comprised of representatives from FRA, the Association of American Railroads, Railway Progress Institute, and several major tank car manufacturers. Based on the information provided at the committee meetings and FRA's prior enforcement of the requirements pertaining to operating platforms on these tank cars, this technical bulletin and its attachments provide guidance regarding the various methods of manufacture and repair of operating platforms and operating platform safety railings on these tank cars that are acceptable to FRA.

Section 231.21(j) requires the operating platforms and related safety railings on tank cars without underframes to be "securely attached" or "securely fastened." FRA has a longstanding interpretation of these phrases which requires that the safety appliances be mechanically fastened. See MP&E Technical Bulletin 98-14. However, FRA believes it is necessary and consistent with both safety and FRA's previous enforcement of part 231 to exercise its enforcement discretion and continue to allow the weldment of certain portions of the safety appliances on these operating platforms. Tank cars have been manufactured for numerous years with operating platforms that have handrails welded to stanchions and stanchions welded to car body brackets. Tank cars built in this manner

have operated for decades without creating any known safety hazard. Thus, FRA will not take exception to existing equipment with these types of safety appliance arrangements, but will require mechanical attachment of such appliances on all tank cars with operating platforms built after January 1, 2000 and when repairs are required on equipment built prior to that date. See Exhibit G, Figures 17 and 18.

Similarly, FRA has allowed safety railings on operating platforms to be repaired utilizing weldment under certain controlled conditions. Thus, the guidance contained in this bulletin merely acknowledges repair and fabrication requirements for safety railings on operating platforms that are consistent with existing practices to which FRA has not taken exception in the past. FRA believes that the fabrication and repair requirements related to handrails, contained in Exhibits A and F, Figures 13 through 16, do not result in a reduction of the structural integrity of the railings. Furthermore, although weldment is permitted at intermediate points in the railing, the railing is mechanically fastened at the end locations where it is attached to the operating platform or stanchion.

FRA will exercise its enforcement discretion and not take exception to the factory weldment of safety appliance brackets at intermediate locations on the grating of operating platforms. See Exhibits A and D, Figures 7 through 9. There are several reasons for this exercise of discretion. The gratings used on operating platforms have been manufactured for years with these intermediate brackets being directly welded to the gratings, and FRA is not aware of any safety hazards arising from this design. Furthermore, due to the high quality of factory welds, a mechanical fastener would add little or no structural strength to the attachment. In addition, this type of weldment will be permitted only on intermediate brackets, where less stress is being placed on the attachment. All platform attachments at end supports will be required to be mechanically fastened. See Exhibits A and C, Figures 6 and 6A. Moreover, the only field repair that will be permitted on intermediate brackets will be replacement of the grating assembly with a factory-made assembly or application of mechanical fasteners. See Exhibits A and D, Figures 7 through 9.

The guidance contained in this bulletin applies only to operating platforms on tank cars without underframes and is not intended to apply to safety appliances at any other location on a car.

Attachments: A through I

EXHIBIT A:

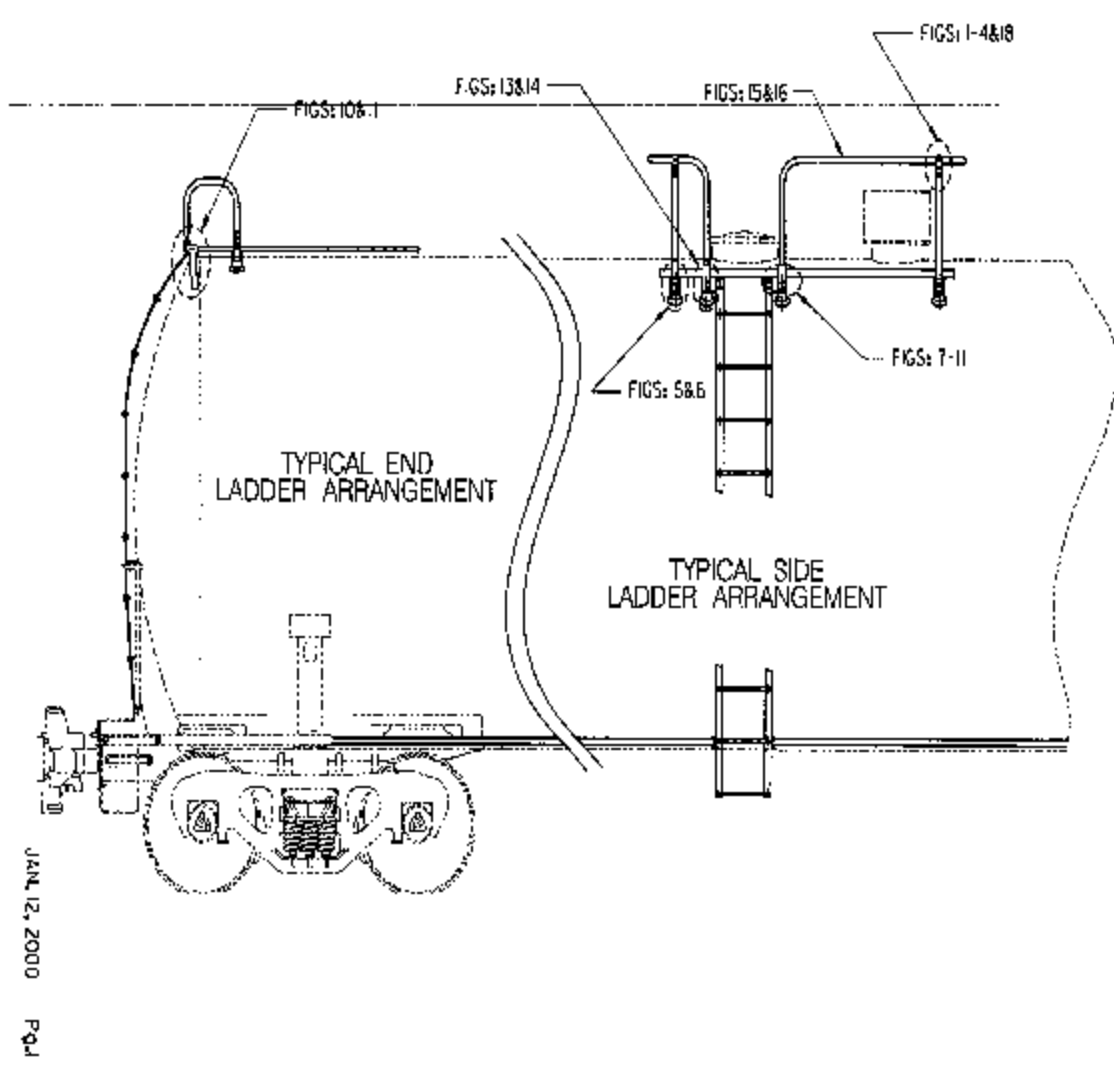
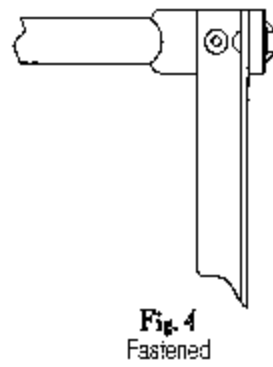
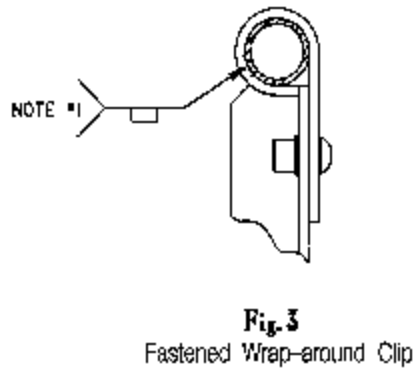
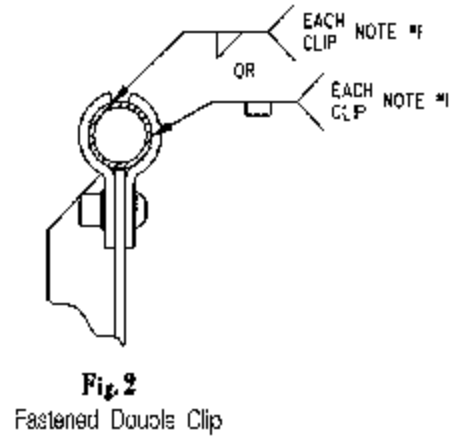
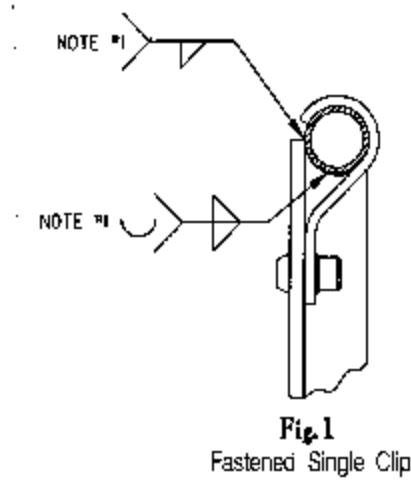

EXHIBIT B:

STANCHION TO RAILING ATTACHMENT OPTIONS



NOTE #1: Welding in addition to Mechanical Fasteners is acceptable at the option of industry. Additional fasteners are acceptable.

Exhibit C:

TYPICAL GRATING ASSEMBLY, WELDING

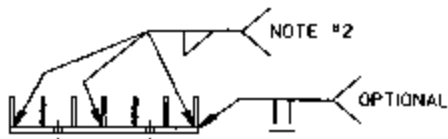
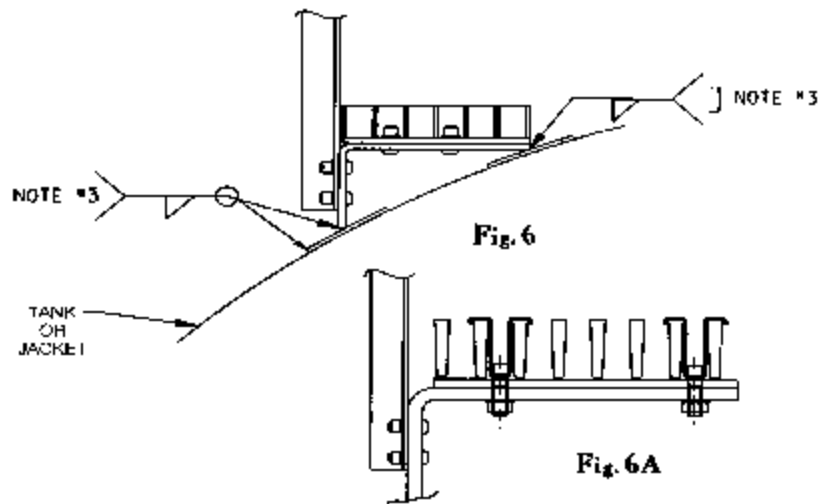

Fig. 5

TYPICAL PLATFORM ATTACHMENT AT END SUPPORTS



NOTE #2: Factory Welds or Mechanical Fasteners are acceptable securement at these locations. Field repairs require Mechanical Fasteners or Factory Made Assemblies.

NOTE #3: Field welding acceptable at these locations.

Exhibit D:

ATTACHMENT TO GRATING AT INTERMEDIATE LOCATIONS

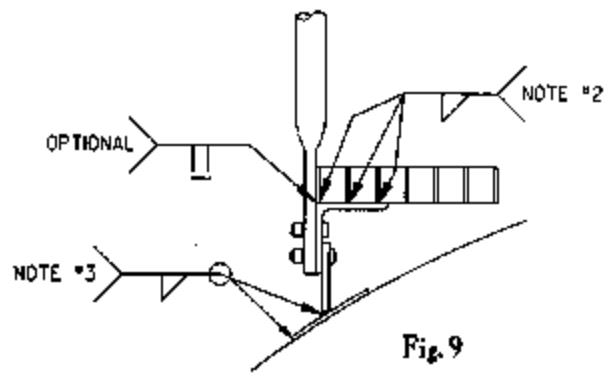
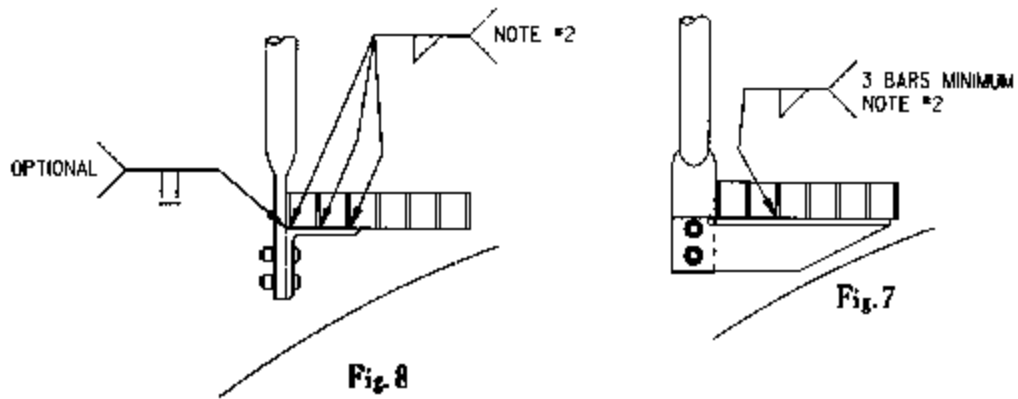

NOTE #2: Factory Welds or Mechanical Fasteners are acceptable securement at these locations. Field repairs require Mechanical Fasteners or Factory Assemblies.

NOTE #3: Field welding acceptable at these locations.

Exhibit E:

TYPICAL LADDER TO GRATING ATTACHMENT

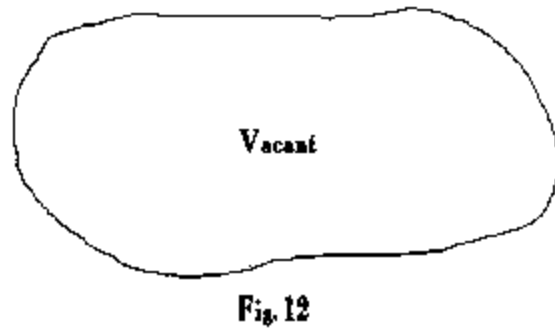
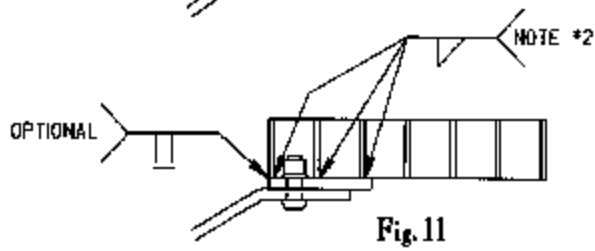
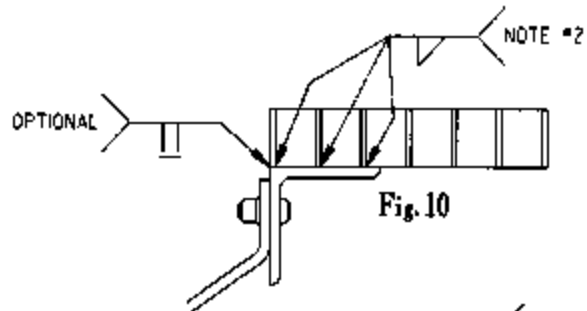

NOTE #2: Factory Welds or Mechanical Fasteners are acceptable securements at these locations. Field repairs require Mechanical Fasteners or Factory Made Assemblies.

FABRICATION AND REPAIR OF PIPE RAILING

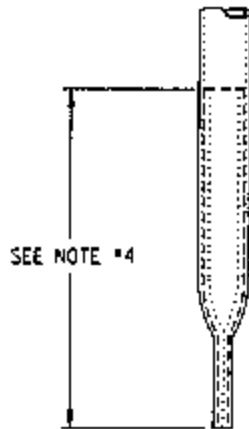

Fig. 13
Typical
Reinforcement Insert
where Flattened

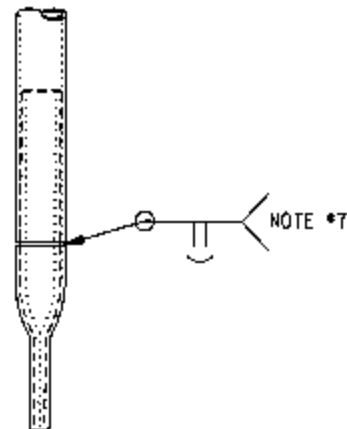

Fig. 14
Typical Repair
See Note 5

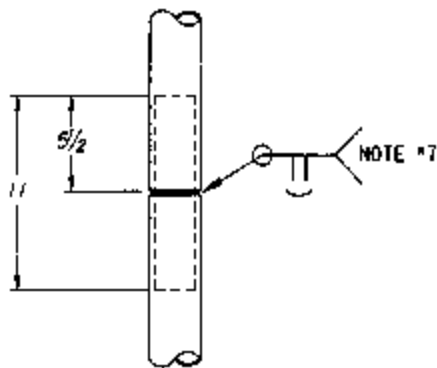

Fig. 15
See Note 6

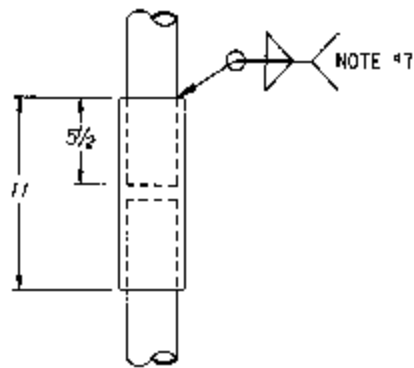

Fig. 16

NOTE #4: When safety railing is 1 1/4 inch pipe and involves flattening, pipe must be reinforced with a steel pipe insert at least 11 inches long or twice the length of the flattened portion, whichever is greater.

NOTE #5: Repair in accordance with AAR Interchange Rule 81 Figure 81, 1999 revision, attached.

NOTE #6: In Accordance with 6/28/96 FRA Letter to UTC and sketch x-6994.

NOTE #7: Break sharp edges

Exhibit G:

*ATTACHMENTS APPROVED ONLY FOR
EXISTING CARS BUILT PRIOR TO JAN. 01, 2000

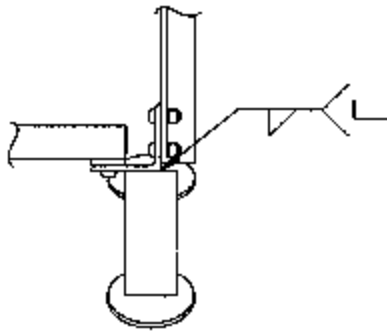

Stanchion to Bracket Attachment*

Fig. 17

See Note 8

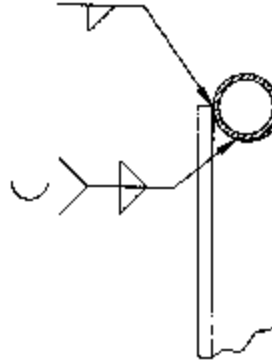

Railing to Stanchion Attachment;
AJ-Welded*

Fig. 18

See Note 9

NOTE *8: Field repairs require mechanical attachment similar to Figure 6.

NOTE *9: Field repairs require mechanical fasteners similar to Figures 1 thru 3.

RULE 81 TANK AND TANK CAR REPAIRS

A. Cause For Repairs

1. As required

B. Correct Repairs

1. End platform safety railing may be removed in kind or substituted for each other when used as specified. Providing steel pipe and solid steel are not alternated.
 - a. 1 1/2 inch schedule 40 steel pipe.
 - b. 3/4 inch diameter solid steel.
2. When safety railing is 1 1/2 inch pipe and twelve flattening, pipe must be reinforced with a steel pipe inset at least 11 inches long or twice the length of the flattened portion, whichever is greater (see Figure A).
3. Tank cars with tanks requiring welded repair, removal of deformations, alteration, conversion or qualification must be processed in a facility that has a current AAR M-1003 Certification per AAR Specification for Quality Assurance, Section 7.

C. Recondition Requirements

1. As required

D. Welding Requirements

1. Welding is not permitted to tanks or tank cars unless:
 - a. Facility (or an extension thereof) performing welding is certified to M-1002 and M-1011 by the AAR for welded repairs to tanks of welded construction.
 - b. All applicable requirements of the current Hazardous Materials Regulations of the Department of Transportation and Appendix F of AAR Specifications for Tank Cars have been complied with.
2. On tank cars without continuous center sills (area sill design), welding of cracks in parent metal of the sills will structural members, or in sills-bonded webs, is not permitted if any portion of the cracks are within 12 inches of the attachment of the sills to the tank reinforcing plate, except welding which is performed by welders qualified in accord with the latest revision of AAR's Specifications for Tank Cars, and by a M-1002/M-1003 certified facility.
3. Welding is not permitted to the following:
 - a. Tank car end platform safety railings, side railings, or operating platform safety railings, all other than as guards, except as shown in Figure A, or as provided for in the original approved design.

RULE 81

FIGURE A

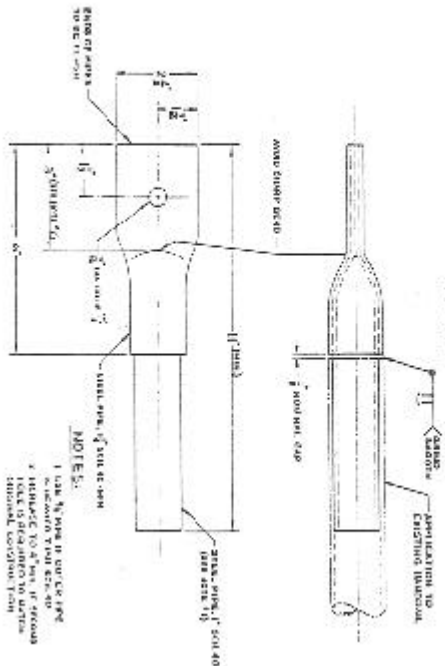

E. General Information

1. For items of repair to tank cars that are common to all cars, see the specific Rule that governs.
2. Painting tanks of tank cars, including underframe and rails, will be excepted as outlined in Rule 80.
3. For actual time in repairing and testing tank of tank car, see Rule 72.
4. Cleaning tanks of tank cars, in connection with repairs to tank proper, shall be as set forth in Rule 75.
5. Repairs to tank car head shields and their attachments (excluding hand brake and safety appliances) shall be performed only in the direction of the car owner and by an AAR certified shop as shown in Appendix B of Specifications for Tank Cars.
6. Pipe clamp must not be used in making repairs to hardware of tank cars.
7. Additional change may be made for accessories such as pipe clamps which require R&R or R in order to make repairs.
8. The application of hardware tank car mandatory safety platform hardware as provided for in the original approved construction shall be reported on a separate basis per Rule 74.

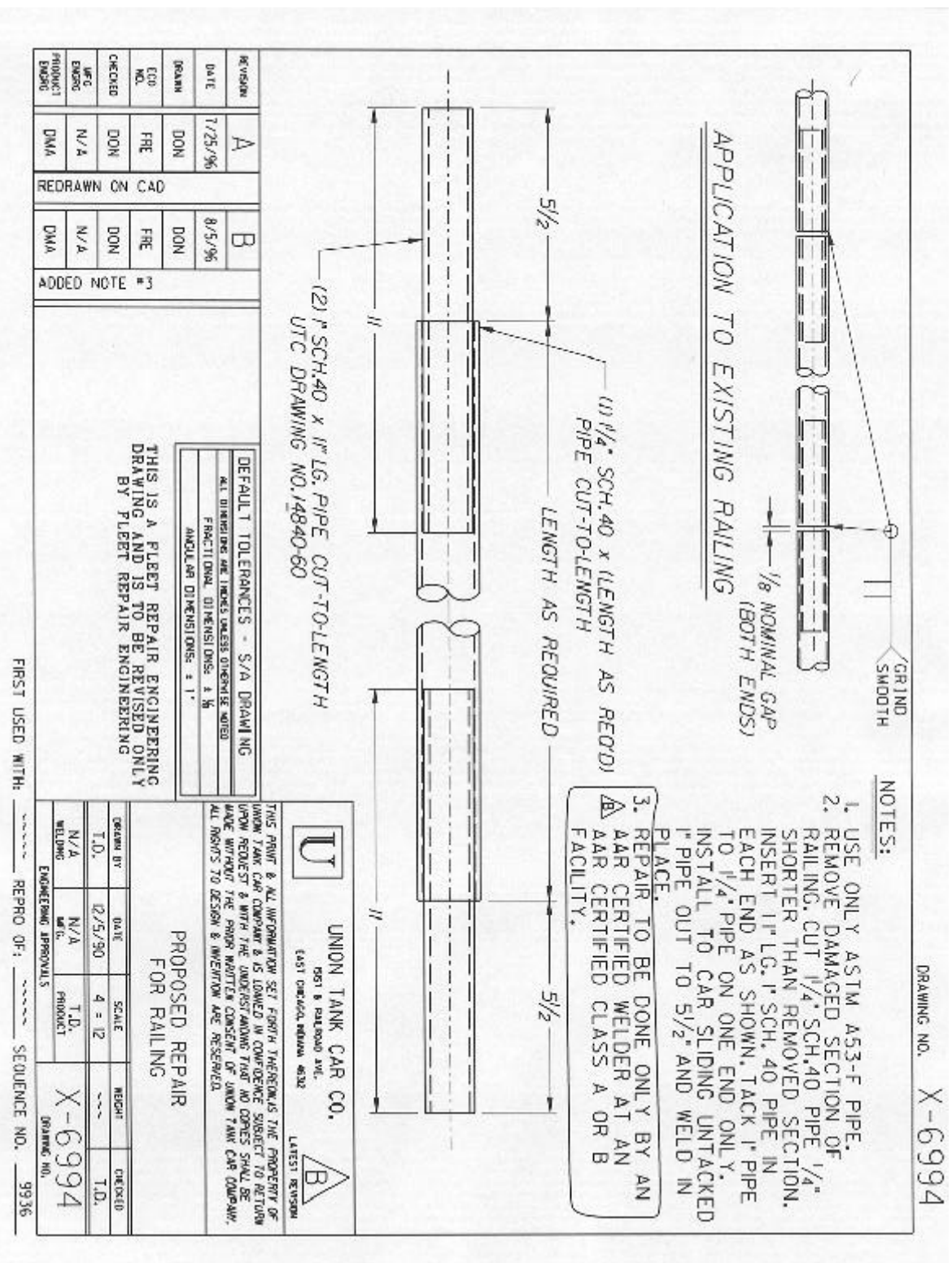

DRAWING NO. X-6994

NOTES:

1. USE ONLY ASTM A53-F PIPE.
2. REMOVE DAMAGED SECTION OF RAILING. CUT 1/4" SCH.40 PIPE 1/4" SHORTER THAN REMOVED SECTION. INSERT 1" LG. 1" SCH. 40 PIPE IN EACH END AS SHOWN. TACK 1" PIPE TO 1/4" PIPE ON ONE END ONLY. INSTALL TO CAR SLIDING UNTACKED 1" PIPE OUT TO 5 1/2" AND WELD IN PLACE.
3. REPAIR TO BE DONE ONLY BY AN AAR CERTIFIED WELDER AT AN AAR CERTIFIED CLASS A OR B FACILITY.

REVISION	A	
DATE	7/25/96	
DRAWN	DN	
ECO NO.	FRE	
CHECKED	DN	
JFC	N/A	
ENGINEERING	N/A	
PRODUCT	DMA	

REVISION	B	
DATE	8/5/96	
DRAWN	DN	
ECO NO.	FRE	
CHECKED	DN	
JFC	N/A	
ENGINEERING	N/A	
PRODUCT	DMA	

REDRAWN ON CAD
ADDED NOTE #3

DEFAULT TOLERANCES - S/A DRAWING
ALL DIMENSIONS ARE UNLESS OTHERWISE NOTED
FRACTIONAL DIMENSIONS: 1/16
ANGULAR DIMENSIONS: ± 1°

THIS IS A FLEET REPAIR ENGINEERING DRAWING AND IS TO BE REVISED ONLY BY FLEET REPAIR ENGINEERING

FIRST USED WITH: _____ REPRO OF: _____ SEQUENCE NO. 9936



UNION TANK CAR CO.
1951 S. PALMWOOD AVE.
EAST OAKLAND, MICHIGAN 48022



LATEST REVISION

THIS PRINT & ALL INFORMATION SET FORTH THEREON IS THE PROPERTY OF UNION TANK CAR COMPANY & IS LOANED IN CONFIDENCE SUBJECT TO RETURN UPON REQUEST & WITH THE UNDERSTANDING THAT NO COPIES SHALL BE MADE WITHOUT THE PRIOR WRITTEN CONSENT OF UNION TANK CAR COMPANY. ALL RIGHTS TO DESIGN & INVENTION ARE RESERVED.

PROPOSED REPAIR FOR RAILING

DESIGN BY	DATE	SCALE	WEIGHT	CHECKED
T.D.	12/5/90	4 = 1/2	---	T.D.
WELDING	N/A	T.D.		
ENGINEERING APPROVALS				
				X-6994